



ABSTRACT

This guide book is a valuable quick guide to find important resources for MSP430™ microcontrollers (MCUs). This book serves many purposes – a resource and reference handbook, a getting started guide, a self-learning tool, a solution manual to find the answers to your questions or a guide book when you develop specific applications. Regardless of your experience level with MSP430 MCUs, you can benefit from this development guide book. If you have any comments or ideas for the next edition of this guide book, you can give feedback by creating a thread in the [TI E2E™](#) support forums in the [MSP low-power microcontroller forum](#).

Table of Contents

1 Overview	3
1.1 Overview of MSP430 MCUs	3
1.2 MSP430 Ecosystem	3
1.3 Quick Link to Frequently Asked Questions	5
2 TI Online Resources	6
2.1 TI.com Overview	6
2.1.1 Introduction to TI.com	6
2.1.2 TI Cloud Tools	6
2.1.3 Online Support	8
2.2 MSP430 Online Resources	9
2.2.1 MSP430 Home Page	9
2.2.2 MSP430 Product Page	10
2.2.3 MSP430 Device Selection	11
3 PC Software Tool Resources	13
3.1 Programming-Related Software	13
3.2 MSP430 Software Development Kits	14
3.3 GUIs for MSP430 MCUs	15
4 Embedded Resources	16
4.1 Technical Documentation	16
4.2 Embedded Software	16
4.3 Debuggers and Programmers	17
4.4 Development Boards	19
5 MSP430 Application Resources	21
5.1 Device-Related Application Notes	21
5.2 System-Level Solutions	24
5.2.1 Typical MSP430 Reference Designs	24
5.2.2 TI Reference Designs	27
5.2.3 System-Related Application Notes	28
5.3 Encryption and Security	29
6 TI Quality Introduction	31
6.1 TI Quality Policy	31
6.2 TI Product Reliability	31
6.3 TI Packaging Introduction	31
6.4 Customer Returns	31
7 Revision History	32

Trademarks

MSP430™, TI E2E™, and Code Composer Studio™ are trademarks of Texas Instruments.

Windows® is a registered trademark of Microsoft.

macOS® is a registered trademark of Apple Inc.

Linux® is a registered trademark of Linus Torvalds.

All other trademarks are the property of their respective owners.

Terms and Abbreviations

Abbreviation /Term	Definition / Explanation
FRAM	Ferroelectric random access memory (FeRAM, F-RAM or FRAM)
GUI	Graphical user interface
IDE	Integrated development environment
BSL	Bootloader
DSP	Digital signal processing
JTAG	JTAG (named after the Joint Test Action Group) is an industry standard for verifying designs and programming printed circuit boards before or after manufacturing
SBW	2-wire Spy-Bi-Wire interface, a typical JTAG interface for MSP430 MCUs
MSP	Mixed Signal Processor
CapTlvate	Capacitive sensing
USS	Ultrasonic sensing
NVM	Nonvolatile memory
PC	Personal computer

1 Overview

1.1 Overview of MSP430 MCUs

The 16-bit MSP430 microcontroller (MCU) family provides affordable solutions for many applications. TI's leadership in integrated precision analog helps designers enhance system performance and reduce system costs. Designers can find a cost-effective MCU within the broad portfolio of MSP430 MCUs, with over 2000 devices for virtually any need. Designers can get started quickly and reduce time to market with our simplified tools, software, and best-in-class support. At present, there are two main series based on the type of nonvolatile memory (NVM)—the Flash families and the FRAM families. The FRAM MCUs consume lower power and combine the characteristics of Flash and RAM. The Flash series includes MSP430x1xx, MSP430x2xx, MSP430x4xx, MSP430x5xx and MSP430x6xx. The FRAM series includes MSP430FR2xx, MSP430FR4xx, MSP430FR5xx, and MSP430FR6xx. Among them, MSP430x5xx/6xx and MSP430FR5xx/6xx are higher and the internal peripherals are more abundant.

The internal resources of most MSP430 families are shown in [Table 1-1](#).

Table 1-1. MSP430 Resources

Series	CPU Frequency (MHz)	Operating Temperature (°C)	NVM (KB)	RAM (KB)	SAR ADC Resolution	GPIO Pins	I ² C	SPI	UART
FRAM ⁽¹⁾	16 to 24	-40 to 85, -40 to 105	0.5 to 256	0.5 to 12	NA, 10-bit, 12-bit	12 to 83	0 to 4	1 to 8	1 to 4
Flash	8 to 25	-40 to 85, -40 to 105	0.5 to 512	0.125 to 66	NA, 10-bit, 12-bit	4 to 90	0 to 4	0 to 8	0 to 4

(1) For more description of the difference between FRAM and Flash, see the FRAM section in [Section 5.1](#).

The peripherals of MSP430 series are shown in [Table 1-2](#).

Table 1-2. MSP430 Peripherals

Series	Common Peripherals	Performance Peripherals
FRAM	RTC, DMA, Watchdog, Timer, UART, SPI, I ² C, LCD controller, CRC module, AES accelerator, 32-bit Hardware multiplier ⁽¹⁾ , SAR ADC, DAC, Comparator, OPA (operational amplifier)	CapTivate module ⁽¹⁾ ⁽³⁾ , SAC (smart analog combo) ⁽¹⁾ , TIA (transimpedance amplifier) ⁽¹⁾ , ESI (extended scan interface) ⁽²⁾ , LEA (low-energy accelerator) ⁽²⁾ , USS (ultrasonic sensing solution) ⁽²⁾ ⁽³⁾
Flash		USB 2.0 ⁽³⁾ , 24-bit sigma-delta ADC, 16-bit sigma-delta ADC

(1) For these MSP430 unique peripherals, see the [MSP430FR4xx and MSP430FR2xx Family User's Guide](#).

(2) For these MSP430 unique peripherals, see the [MSP430FR58xx, MSP430FR59xx, and MSP430FR6xx Family User's Guide](#).

(3) For these MSP430 unique peripherals, see the [Section 5.2.1](#).

1.2 MSP430 Ecosystem

The MSP430 ecosystem is composed of TI online resources, PC software tool resources, embedded resources and MSP430 application resources. For beginning users of MSP430 MCUs, the simplified ecosystem map shown in [Figure 1-1](#) is a good reference. For experienced users of MSP430 MCUs, the complete ecosystem map in [Figure 1-2](#) provides more details.

Website:

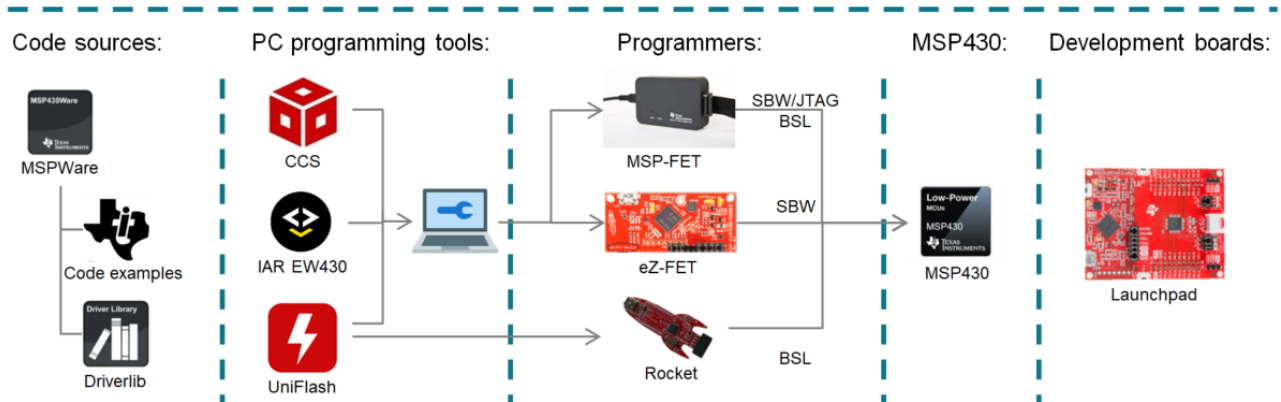

Figure 1-1. Map of Simplified MSP430 Ecosystem

Website:

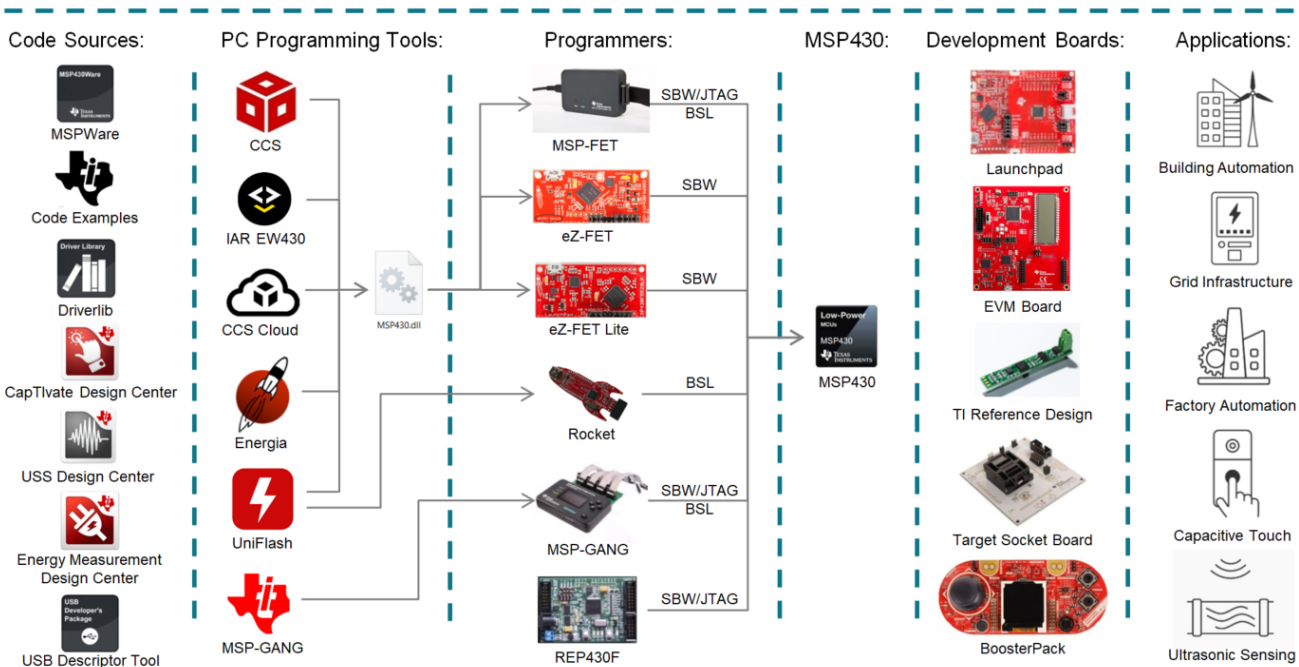

Figure 1-2. Map of Complete MSP430 Ecosystem

- **TI Online Resources:** TI.com contains all MSP430 the related resource and information, including software tools, programmers, development boards, and more. Also, the TI E2E support forums provide online support, discussion, and knowledge sharing.
- **PC Software Tool Resources:** TI and third parties currently provide a variety of PC-side software development tools for MSP430 MCUs, including IDEs, programming software, and GUIs for specific applications.
- **Embedded Resources:** These includes technical documentation, code examples, debuggers, programmers and development boards for developing or evaluating application designs related to MSP430 MCUs.

- [MSP430 Application Resources](#): TI provides device-related application notes, reference designs, security, and quality instructions to help customer better use MSP430 MCUs. Reference designs include overview, supporting software, and hardware design files that can also guide users to develop related projects.

To start developing with MSP430 MCUs, you can buy a [MSP430 LaunchPad development kit](#) and download the [Code Composer Studio™ IDE](#) and [MSPWare](#) to get the example code. To develop an application based on MSP430 MCUs, TI recommends that you use [MSP-FET](#) as the debug probe. For mass production, TI recommends that you to use [UniFlash](#) or [MSP-GANG](#) to download code. For the start of development with MSP430 MCUs, refer to the [MSP430 Design Workshop Student Guide](#). This guide introduces users to the development chain for MSP430 MCUs and peripherals with detailed explanations.

1.3 Quick Link to Frequently Asked Questions

1. [How to find a suitable MSP430 MCU and related resource?](#)
2. [Where to get online training and support?](#)
3. [What about the PC software tools to program MSP430?](#)
4. [Where to get MSP430 code examples?](#)
5. [Where to find the description of MSP430 spec and usage?](#)
6. [What about the MSP430 programming tools?](#)
7. [What about the MSP430 development boards?](#)
8. [Where to find the usage of MSP430 peripherals?](#)
9. [Where to find the resource of USS, CapTivate, USB and Energy Measurement resouces?](#)
10. [How to solve quality issues?](#)

2 TI Online Resources

2.1 TI.com Overview

2.1.1 Introduction to TI.com

Figure 2-1 shows an overview of the main navigation on TI.com.

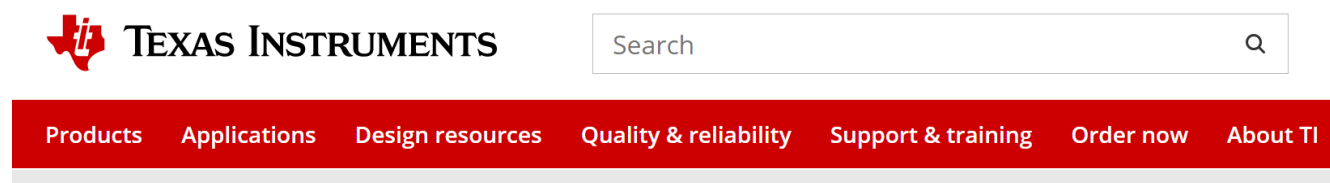

Figure 2-1. TI.com

- **Products ★:** Including TI's current various types of products, which is convenient for customers to browse and choose according to their needs.
- **Application:** The mainstream market solution provided by TI, and includes related mature chip recommendations for those application designs.
- **Design resource:** The material needed when developing products using TI devices, including software and simulation tools, reference designs, hardware symbols and packaging.
- **Quality & reliability:** Includes quality policy, standards and certifications.
- **Support & training:** Includes online support, visualization and graphic training material.
- **Order now:** TI's product order entry. Users can buy directly on TI.com or from TI authorized agents.
- **About TI:** TI company profile, corporate culture, social responsibility, etc.

2.1.2 TI Cloud Tools

- [TI Cloud Tools](#) is a TI online tool website, which provides a wealth of tools, documents, programs, GUIs and other resources. In this website, you can see the following featured sections.

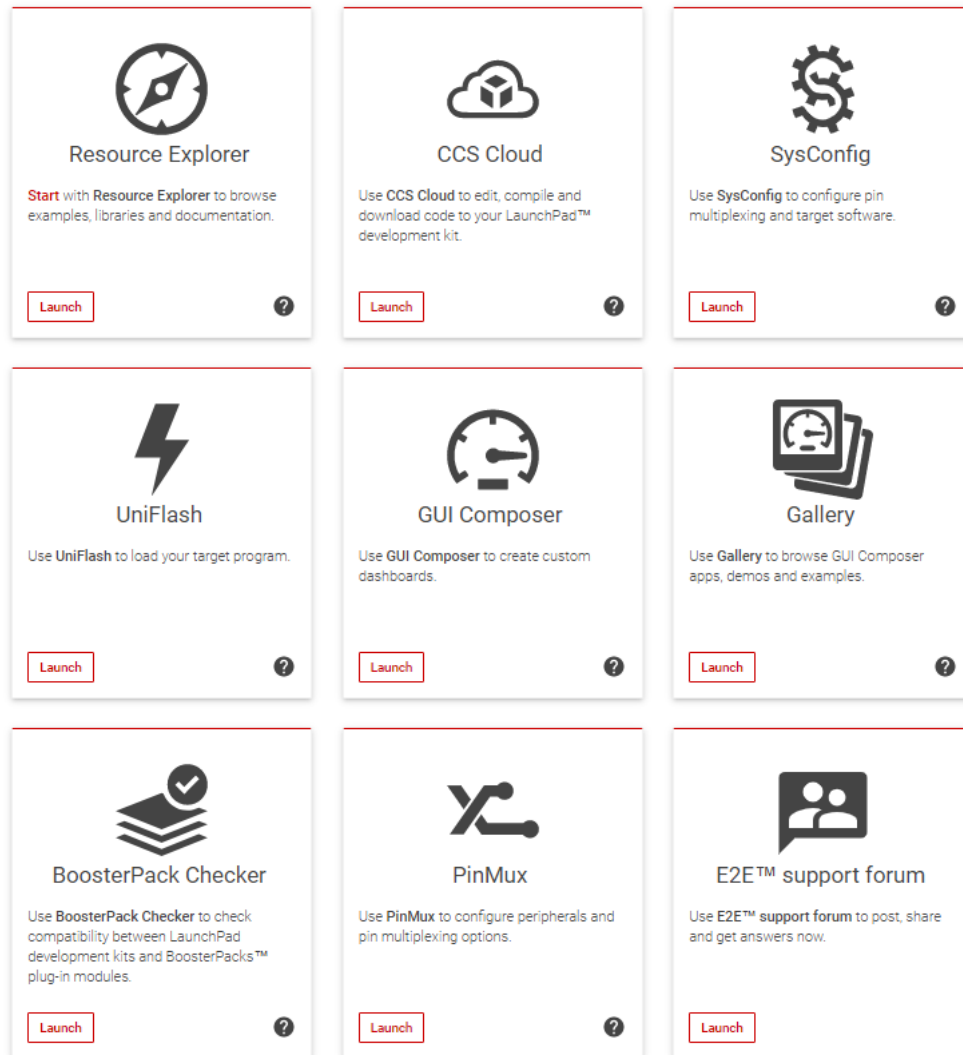

Figure 2-2. TI Cloud Tools

- **Resource Explorer** ★
 - Development Tools: Development tools for TI products.
 - Device Documentation: Related documents for MSP430 and other chips (user's guide, data sheet, and errata).
 - Software: Browse MSP430Ware to find TI's rich software resources that include but are not limited to example code base on register level and library, software driver libraries.
- **CCS Cloud**: Online CCS tool, which can help to quickly debug programs online.
- **SysConfig**: Visual editing method to configure MCU internal resource. (MSP430 MCUs are not supported).
- **UniFlash**: Online programming tools that support viewing and programming MCU internal memory data.
- **GUI Composer**: Online tool for creating a user-defined interface that interacts with the user's hardware.
- **Gallery**: GUI projects shared by users.
- **BoosterPack Check**: Helps to check whether or not the pins of the LaunchPad kit and the BoosterPack modules match.
- **PinMux**: Visual pin function assignment (MSP430 MCUs are not supported).
- **TI E2E Support Forums** ★: Support forums for development engineers.

2.1.3 Online Support

- [TI Training](#)

TI Training provides a wealth of technical training videos, which will give an in-depth explanation of the overall or specific technologies. Leveraging the search bar can help you find the related resource quickly.

For MSP430 MCUs, you can go to the [MSP430 Workshop Series](#) directly.

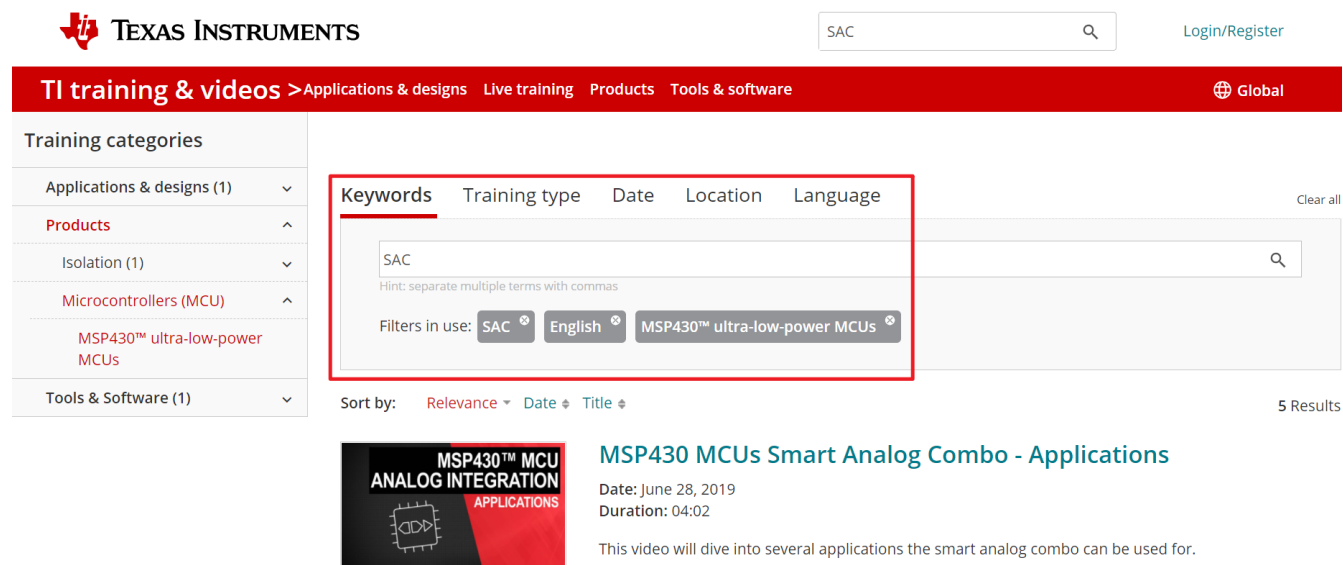

Figure 2-3. TI Training

- [TI E2E Support Forums](#)

- The TI E2E forum is TI's online technical support platform for development engineers. There are many product experts from TI and community designers and technologists participate in the technical discussion. Any technical problems in the product development process can be submitted on this platform. You can also share debugging experience or related knowledge on the TI E2E forum.
- The TI E2E forum is also an open communication platform. On the user's home page, you can view the discussion content and technical articles related to the user. The TI E2E forum also supports direct messaging with friends' private messages.
- [Figure 2-4](#) shows the four main sections in the TI E2E forum.

Welcome to the TI E2E™ support forums

TI E2E support forums are an engineer's go-to source for help throughout every step of the design process. Our engineers answer your technical questions and share their knowledge to help you quickly solve your design issues.

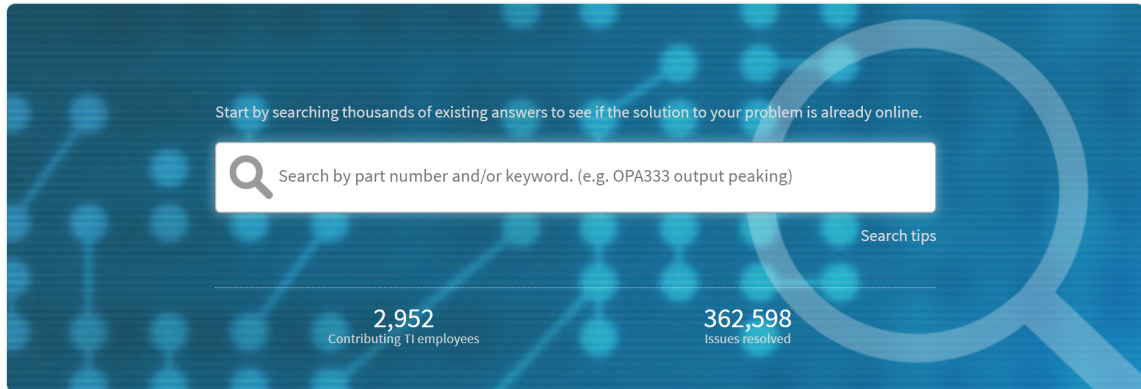

Figure 2-4. TI E2E Support Forums

- **Forums:** TI products are subdivided to help designers to ask technical questions within a smaller product range.
- **Technical articles:** Contains technical information and debugging experience, which can help you query and share relevant technical development experience.
- **TI training:** TI training homepage, which provides a wealth of technical training videos.
- **Getting started★:** A list of FAQs for specific tasks in the TI E2E forum in chronological order.

2.2 MSP430 Online Resources

2.2.1 MSP430 Home Page

- On TI.com, follow the **Products** → **Microcontroller** → **MSP430 ultra-low-power MCUs** path to easily enter the MSP430 home page or enter directly using TI.com/msp430.

The MSP430 home page (see [Figure 2-5](#)) has seven categories of information.



Figure 2-5. Categories on MSP430 Home Page

- **Overview:** The overall introduction of MSP430, including MSP430 product features, performance, and typical resource modules.
- **Products:** Many MSP430 MCU products which can be chosen according to customer needs.
- **Applications:** Application solutions for various popular markets, including but not limited to: building automation, network infrastructure, factory automation and other applications.
- **Reference designs:** Reference designs related to MSP430 provided by TI. Detailed information about hardware, software, and documentation for each reference design can be found there.
- **Design & development:** The materials needed when developing MSP430 products, including debuggers (MSP-FET), LaunchPad kits, evaluation boards, IDE development tools and GUIs.
- **Capacitive sensing:** Development overview for capacitive touch products, including but not limited to capacitive touch principles and other related MSP430 products and applications.

- **Ultrasonic sensing:** Development overview for ultrasonic application products, including but not limited to the introduction of an ultrasonic solution in water meters, gas meters market.

2.2.2 MSP430 Product Page

Every MSP430 has a product page, as shown in [Figure 2-6](#) (using MSP430FR2311 as an example). There is some basic information of the product (for example, operating frequency, memory size, and peripheral resources) and some important files for easy reference and download: data sheet, user’s guide, and errata. You can also find other related information on this page.

Home / Microcontrollers (MCU) / MSP430 ultra-low-power MCUs

Subscribe to updates

MSP430FR2311 ✔ ACTIVE

Order now

16MHz integrated analog microcontroller with 3.75KB FRAM, Op-Amp, TIA, Comparator w/ DAC, 10-bit ADC

[DATA SHEET](#) | [MSP430FR231x Mixed-Signal Microcontrollers datasheet \(Rev. E\)](#) | [Online data sheet](#)

USER GUIDES

ERRATA

[MSP430FR4xx and MSP430FR2xx Family User's Guide \(Rev. I\)](#)

[MSP430FR2311 Device Erratasheet \(Rev. P\)](#)

Figure 2-6. MSP430 Product Page Top

The product page also provides many important resources for reference (see [Figure 2-7](#)).

Product details | Technical documentation | Design & development | Ordering & quality | Support & training

Product details

Parameters | Package | Pins | Size | Features | Description

Features	OpAmp, Real-Time Clock, Transimpedance amplifier
Non-volatile memory (kB)	4
RAM (KB)	1
ADC	10-bit SAR
ADC: channels (#)	8
GPIO pins (#)	16
I2C	1
SPI	2
UART	1
Comparator channels (#)	2

View all

[Find other MSP430 ultra-low-power MCUs](#)

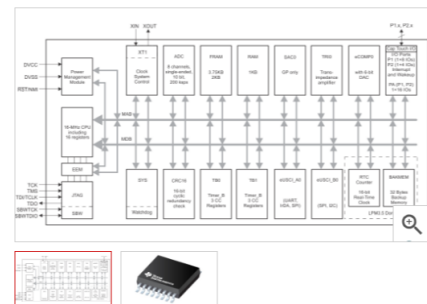

Figure 2-7. MSP430 Product Page Middle

- **Product details:** It includes product details, feature descriptions, block diagram, and more, which can help understand general performance of the product and internal resources.
- **Technical documentation:** Rich technical documentation related to this MSP430 device, including but not limited to: application manuals, technical articles, example code and other resources.
- **Design & development:** Design kits and hardware evaluation boards including but not limited to: product-related reference designs, software, development tools, CAD/CAE symbols and other resources.

2.2.3 MSP430 Device Selection

TI offers a large portfolio of MSP430 MCUs. Today, there are approximately 560 MSP430 devices on TI.com. Here are three ways to find the suitable MSP430 MCU through TI.com.

- Through the [MSP430 product search page](#) ★
 - Enter the on-chip resources that match your needs in the MSP430 product search page on the [MSP430 home page](#). Using the **Quick search** tool, you can quickly find MSP430 devices that meet your basic requirements. In addition, you can use the **filters bar** on the left for accurate search.

Part	FRAM	RAM	ADC Type	GPIO	Package	Features	UART	SPI	I ² C	Comparator	Price
MSP430xx	KB	KB	SAR or SD	–	–	–	–	–	–	–	–

Figure 2-8. MSP430 Search

Other MSP430 MCUs are available for applications including space, military, enhanced products, and high-temperature applications. For these devices, choose the applicable rating.

Figure 2-9. Different Rating

- Through the reference designs page

On the [Reference designs page](#), TI provides a system-level solution. Select the market type or select keywords in the filters. It includes a wealth of reference designs using MSP430 MCUs. Also, users can obtain key documents, software, hardware, BOM and other materials for most reference designs.

Hide filters Reset 326 total designs

Market

- Automotive
- Communications equipment
- Enterprise systems
- Industrial
- Personal electronics

Design title	Market
Filter by keyword(s) <input type="text"/>	
TIDA-010072.1 - NEW - Air blower and valve control reference design for respiratory applications	Industrial
TIDA-010076 - NEW - Daisy-chained power and data over single pair Ethernet (T1) reference design	Industrial
TIDA-010081 - NEW - >95% Efficiency, 1-kW analog control AC/DC reference design for 5G telecom rectifier	Industrial

Figure 2-10. MSP430 Reference Designs

- Through the typical MSP430 applications page

On the [Application page](#), TI provides some mainstream market applications and design solutions for end products, and includes related mature chip recommendations for selection.

Building security systems ^

Access control

Add capacitive touch to your security system keypad and electronic smart lock designs with MSP430 capacitive sensing microcontrollers. Leverage a broad portfolio that can scale with your needs – from discrete touch solutions to SoCs for more system control.

Design challenge	MSP430 advantages & benefits
Energy efficiency / long battery life	Benchmark performance for standby current consumption
Small form factor and board size	Flexible sensor/button design for small board space size
Resistance to harsh elements/environments	IPX5-rated solutions for water/moisture rejection
RF noise immunity	Spread spectrum modulation and frequency hopping techniques to reduce antenna interference
Time to market	Real-time tuning and code generation with CapTIvate Design Center



Featured devices	Tools and development kits	Design resources
MSP43FR2676	CapTIvate Design Center GUI	Application note: CapTIvate Design Flow Guide
MSP430FR2533	MSP430 CapTIvate Touch Keypad BoosterPack	Reference design: Liquid Tolerant Capacitive Touch Keypad
MSP430FR2522	MSP430FR2676 MCU board	Reference design: CapTIvate Electronic Lock and Keypad
		Reference design: Access Control Panel with Capacitive Touch and BLE

Figure 2-11. MSP430 Applications

3 PC Software Tool Resources

3.1 Programming-Related Software

Table 3-1 lists the compatibility of different programming tools for MSP430 MCUs. The MSP-GANG programmer supports only MSP-GANG hardware. Other command-line tools like MSP Flasher and BSL Scripter have been combined into UniFlash.

Table 3-1. Programming Tools Compatibility

Features	CCS	IAR	UniFlash	Energia
Edit code	✓	✓		✓
Compile and debug	✓	✓		✓
JTAG/SBW programming	✓	✓	✓	✓
Bootloader			✓	
Windows® operating system	✓	✓	✓	✓
macOS® operating system	✓		✓	✓
Linux® operating system	✓		✓	✓

- **CCS ★:** Code Composer Studio (CCS) is the IDE tool provided by TI, which is free of charge and also integrates TI Resource Explorer. If the MSP430 MCU is not recognized, download and install the [MSP FET Drivers](#).
 - Product page: [CCS IDE for MSP430](#)
 - User's guide: [Code Composer Studio User's Guide](#)
 - Guide book: [CCS Step-by-step Workshop for MSP430](#)
 - Video link: [Getting Started with Code Composer Studio v9.3](#)
 - Related software development user's guide
 - [CCS documentation MSP430™ Assembly Language Tools User's Guide](#)
 - [MSP430™ Optimizing C/C++ Compiler User's Guide](#)
 - [MSP430 Embedded Application Binary Interface Application note](#)
 - Useful tools integrated into CCS
 - [TI Resource Explorer](#): A resource that contains all materials for developing MCUs and processors.
 - [EnergyTrace](#): An energy-based code analysis tool that measures and displays the energy profile of the MSP430 MCU in an application.
 - [ULP \(Ultra-Low Power\) Advisor](#): A tool can provide ultra-low power improvement suggestions for user's code.
- **IAR EW430:** IAR Embedded Workbench for MSP430 (IAR EW430) is a third party IDE tool provided by IAR.
 - Product page: [IAR Embedded Workbench for MSP430](#)
 - User's guide: [IAR Embedded Workbench® IDE Version 7+ for MSP430™ MCUs](#)
- **UniFlash ★:** UniFlash is a programming GUI tool developed by TI, which supports JTAG and BSL. To program MSP430 MCUs, you need to load a binary file, which can be generated following this [link](#). If the MSP430 MCU is not recognized, download and install the [MSP FET Drivers](#).
 - Product page: [UniFlash](#)
 - User's guides
 - [UniFlash Quick Start Guide](#)
 - [Programming the Bootloader of MSP430™ Using UniFlash](#)
- **Energia:** Energia is an open source and community-driven IDE. It primarily supports those MSP430 MCUs that are available on LaunchPad kits.
 - Product page: [Energia](#)
- **MSP430-GCC:** MSP430-GCC combines debugger and open source C/C++ compiler toolchains for building and debugging embedded applications based on MSP430 and MSP432 microcontrollers.
 - Product page: [GCC - Open Source Compiler for MSP Microcontrollers](#)

- **MSPDS:** The MSP debug stack (MSPDS) consists of a static library on the host system side and embedded firmware that runs on debug tools like MSP-FET. It is open source and can be used to customize a MSP430 debugging software tool.
 - Product page: [MSP Debug Stack](#)

3.2 MSP430 Software Development Kits

Offline MSP430Ware: It is a collection of resources that helps users to effectively create and build MSP430 code. It contains user manuals, code examples, and MSP430 driver libraries for MSP devices or libraries based on typical applications. It is also integrated into TI Resource Explorer, which can be found in CCS and online.

- Product page: [MSP430Ware for MSP Microcontrollers](#)
- Folder type introduction

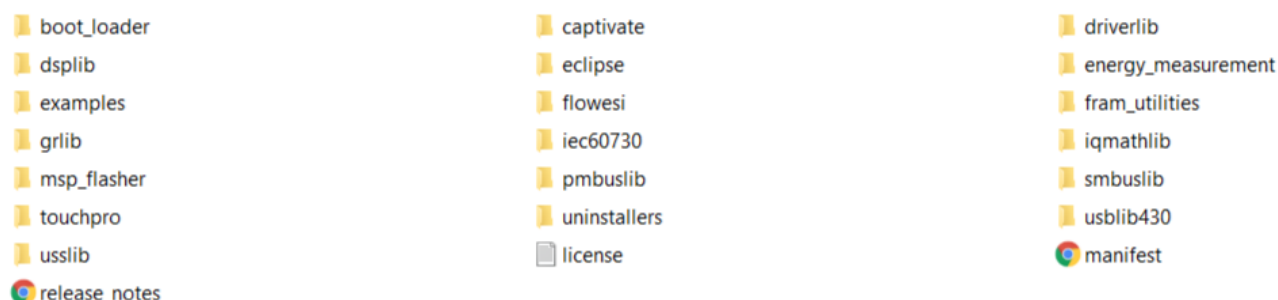

Figure 3-1. Offline MSP430Ware Content

- Code examples
 - Examples: It contains register-level code examples based on development boards and chips. They support both CCS, IAR.
 - DriverLib: It contains source files, routines, and corresponding documents of the MSP430 driver library. They support both CCS, IAR.
- Typical application-specific libraries (They contain GUIs, source files, code examples and related documents)
 - These folders are Captivate (CapTlvate Design Center and Software Library), [usplib](#) (USSSwLib), [energy_measurement](#) (Energy Measurement Library), [usblib430](#) (USB Developer's Package), [flowesi](#) (Linear and Rotational Motion Detection Library), [gplib](#) (Graphics Library) and [Dsplib](#) (DSPLib) .
- Other application libraries (They contain source files, routines and corresponding documents)
 - These folders are iec60730 (IEC60730 Library), iqmathlib (IQmath Library), pmbuslib (PMBusLib), smbuslib (SMBusLib).
- Other types
 - boot_loader: It contains related documents of bootloader and customized bootloader.
 - fram_utilities: It contains development routines and documentation based on the characteristics of FRAM.
 - mcp_flasher: It is a MSP430 command line download software which is replaced by UniFlash and not maintained.
 - **Online MSP430Ware:** it refers to the MSP430Ware in TI Resource Explorer. The biggest difference between the Online and offline version is that you can find more information in the Development Tools folder of the online version about development tools, including IDE, programming software tools, debug probe, development boards, etc. Besides, you can download the typical examples or documents without downloading a whole package.
 - Product page: [Online MSP430Ware](#)
 - Folder directory introduction

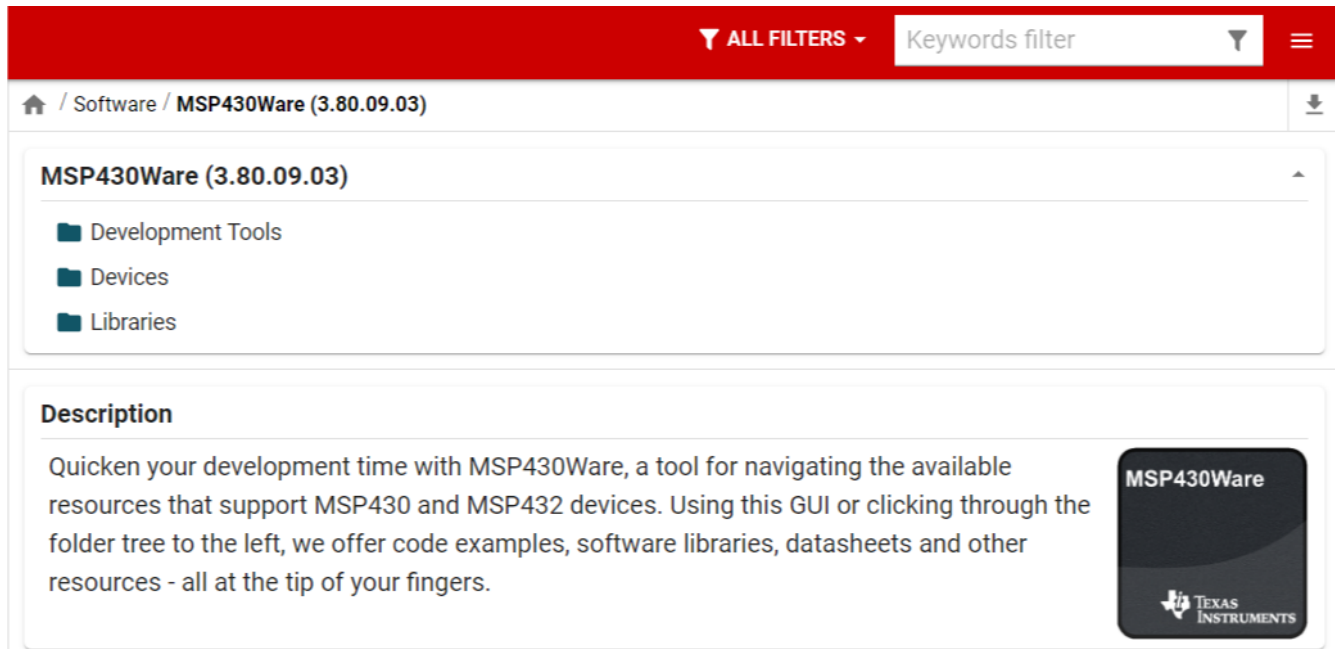

Figure 3-2. Online MSP430Ware Content

- **Development tools:** Includes the information of software demos or examples of IDE, programming software tool, debug probe, development boards, etc.
- **Devices:** Device families related code examples.
- **Libraries:** Different driver libraries or application libraries.

3.3 GUIs for MSP430 MCUs

To help customers develop some complex applications, TI has developed GUIs for these applications.

- [CapTivate™ Design Center](#): A one-stop resource for everything related to CapTivate capacitive sensing technology integrated on TI MSP430™ microcontrollers.
- [Ultrasonic Sensing Design Center](#): A one stop resource to develop ultrasonic sensing applications using MSP430™ microcontrollers (MCUs).
- [Energy Measurement Design Center](#): A rapid development tool that enables energy measurement using TI MSP430i20xx and MSP430F67xxA flash-based microcontrollers (MCUs).
- [MSP430 USB Developers Package](#): A software package containing all necessary source code and sample applications required for developing a USB-based MSP430 project.
- [FlowESI GUI for flow meter configuration using the Extended Scan Interface \(ESI\)](#): The FlowESI GUI allows user to develop configuration code for the ESI module without having to break open the User's Guide! Follow the simple graphical instructions and connect upto 3 LC sensors to the extended SCAN Interface module.
- [MSP Graphics Library](#): A royalty-free set of graphics primitives for creating graphical user interfaces on MSP430 and MSP432 microcontroller-based boards that have a graphical display. For Image Reformer Tool, it is an Image size and color depth manipulation utility used in Graphics Library.
- [Digital Signal Processing \(DSP\) Library](#): A set of highly optimized functions to perform many common signal processing operations on fixed-point numbers for MSP430 microcontrollers. The DSPLib GUI can be used to design an Optimized DSP Library for MSP MCUs.
- [MSP430 Baud Rate Converter](#): A tool for calculating USCI and EUSCI related registers according to the required baud rate.

4 Embedded Resources

4.1 Technical Documentation

Data sheet ★: This document introduces the parameters and functional data information of various MSP430 MCUs, including pin function, performance parameters of its peripherals, and MCU itself including internal signal connections, physical characteristics, product packaging, and packaging. The data sheet is the basic reference document for a typical MSP430 device.

- Download the document on the corresponding [MSP430 product page](#).

Family user's guide ★: Introduces the application method and characteristic of MSP430 MCUs, including but not limited to the abstract model of CPU and peripherals, working mode, and corresponding register configuration method.

- Flash series
 - [MSP430x1xx Family User's Guide](#)
 - [MSP430x2xx Family User's Guide](#)
 - [MSP430i2xx Family User's Guide](#)
 - [MSP430x4xx Family User's Guide](#)
 - [MSP430x5xx and MSP430x6xx Family User's Guide](#)
- FRAM series
 - [MSP430FR4xx and MSP430FR2xx Family User's Guide](#)
 - [MSP430FR57xx Family User's Guide](#)
 - [MSP430FR58xx, MSP430FR59xx, and MSP430FR6xx Family User's Guide](#)

Errata ★: Describes silicon behavior that differs from the documentation for MSP430 MCUs in some application scenarios, functions, or parameters. Also describes the behavior, causes, and solutions. Errata should be used with data sheets during MSP430 product development.

- Download the document on the corresponding [MSP430 product page](#).

Application note: Technical document about device, device peripherals or applications, which is the most common type of technical documentation you can find on TI.com.

White paper: General introduction about device, device peripherals or applications.

Technical article: Describe device, device peripherals or applications in a blog form. Its content will be short and flexible.

- Home page: [Embedded processing](#)

4.2 Embedded Software

MSP430 code examples ★: MSP430 code examples are self-contained low-level programs that typically demonstrate a single peripheral function or device feature in a highly concise manner, written in C or assembly. It supports both CCS and IAR IDE.

- Product page: Go through the Design & development tab in the [MSP430 product page](#) of a typical MSP430 device.

MSP Driver Library: It contains software APIs that abstract away the details of the device's hardware registers and examples showing how to use DriverLib APIs in your project. It supports both CCS and IAR IDEs. Using DriverLib will be make development easier, but at the expense of efficiency.

- Product page: [MSP Driver Library](#)

MSP430™ Value Line Sensing Function Code Examples: A collection of 25 code examples using MSP430FR2xxx. These code examples allow developers to add programmability to simple digital and analog functions, such as timers, input/output expanders, system reset controllers, EEPROM, and more.

- Product page: [MSP430™ Value Line Sensing Function Code Examples](#)

Other software libraries: For other libraries, see [Section 3.2](#).

Open source RTOS: MSP430 supports a variety of open source RTOS systems. Here we list TI-RTOS and FreeRTOS related resources. For other open source RTOS systems, visit the [OSRTOS website](#).

- **TI-RTOS:** TI-RTOS is a real-time operating system for TI microcontrollers, which is free of charge. The latest version for MSP430 is 2.20.00.06 (22 Jun 2016). Till now there is no plan for update. We strongly advise you to use no-RTOS on MSP430.
 - Product page: [TI-RTOS Product Releases and Download Links](#)
- **FreeRTOS:** FreeRTOS is a market-leading RTOS. Distributed freely under the MIT open source license, it includes a kernel and a growing set of libraries suitable for use across all industry sectors.
 - Product page: [FreeRTOS](#)

4.3 Debuggers and Programmers

[Table 4-1](#) compares different MSP430 programmer tools recommended by TI.

Table 4-1. Comparison of Debugger and Programmer Tools

Features	eZ-FET	MSP-FET	eZ-FET Lite	MSP-FET430UIF	MSP-GANG	REF430F	Rocket
Type	Debugger	Debugger	Debugger	Debugger	Programmer	Programmer	Programmer
4-wire JTAG		✓		✓	✓	✓	
2-wire JTAG (SBW)	✓	✓	✓	✓	✓	✓	
BSL tool or mode		✓			✓		✓
USB Backchannel UART	✓	✓					
Supported by CCS / IAR	✓	✓	✓	✓			
Supported by UniFlash	✓	✓	✓	✓			✓
EnergyTrace	✓	✓					
Application	Development	Development	Development	Development	Production	Production	Firmware update

[Table 4-2](#) compares different programming methods.

Table 4-2. Comparison of Debug and Programming Methods

Features	SBW	JTAG	BSL	Main memory BSL
Debug	✓	✓		
Program	✓	✓	✓	✓
Programming pins	2	4	2 or 3	2 or 3
Invoke pin (RST, TEST)	✓	✓	✓	
Protocol	2-wire JTAG	4-wire JTAG	UART, SPI, I ² C, USB	UART, SPI, I ² C, USB
Advantages	Need fewer pins and traces than JTAG	More stable and faster than SBW	Simplest programming interface	Support customized BSL

Debugger (Debug probe): Powerful emulation development tools that support all MSP430 JTAG and SBW debugging interfaces, which can be used for debugging and programming. CCS supports four debuggers: eZ-FET, eZ-FET Lite, MSP-FET, and MSP-FET430UIF.

Programmer: Products made for only programming. It mainly includes MSP-GANG and Rocket.

- User's guide★
 - [MSP Debuggers User's Guide](#)
- Related products
 - **MSP-FET ★:** It is the most powerful and fastest MSP430 debug probe. Target VCC is selectable and the maximum supply current is 100 mA.
 - Product page: [MSP-FET MSP MCU Programmer and Debugger](#)
 - **eZ-FET ★:** It is a low-cost MSP430 debug probe and usually sold with LaunchPad kits. Besides, it only supports a fixed voltage power supply.
 - Product page: See the specific LaunchPad's product page.
 - **eZ-FET Lite:** It is a low-cost MSP430 debug probe and usually sold with LaunchPad kits, which removes EnergyTrace from eZ-FET. It is also an open source debug probe for customers to customize their own debug probe.
 - Product page: See the [MSP430F5529 LaunchPad kit](#) product page.
 - Open source version page: [MSP430_ezFETLite](#)
 - **MSP-GANG ★:** The MSP Gang Programmer can't debug code and is used for product production. It can be operated without a PC and supports programming eight MSP430 at the same time.
 - Product page: [MSP-GANG Production Programmer](#)
 - **Rocket ★:** It cooperates with UniFlash and mostly used for downloading and erasing. TI provides source code and hardware design.
 - Product page: [MSPBSL_Rocket](#)
 - **REF430F:** It is an open source product production tool, which is used for customer to customize, which can be used to learn JTAG communication protocol.
 - Product page: [Elprotronic, Inc. Replicator for MSP430 MCU](#)
 - User's guide: [MSP430 Programming With the JTAG Interface](#)
 - **MSP-FET430UIF:** It is a previous generation of MSP-FET, which isn't available anymore on TI.com.
 - Product page: [MSP-FET430UIF](#)
 - **EnergyTrace:** It is an energy-based code analysis tool that measures and displays the energy profile of an application, including the software and hardware part. For the software part, it is integrated in CCS and IAR.
 - Product page: [EnergyTrace Technology](#)
 - User's guide: [ULP Advisor™ Software and EnergyTrace™ Technology](#)
 - **USB2ANY interface adaptor:** A tool intended to allow a computer to control an evaluation module (EVM) via a USB connection, which supports multiple popular protocol interfaces.
 - Product page: [USB2ANY interface adaptor](#)
 - User's guide: [USB2ANY Interface Adapter User's Guide](#)

Bootloader (BSL) This is a software upgrade program that stored in Flash or ROM from the factory. It is mainly used for code programming, erasing and reading in RAM, main memory and information memory. When updating a program through the BSL, the communication interface and RST and test pins are occupied. For supported communication interface, see the *Bootloader (BSL)* section in the device-specific data sheet.

- Customized BSL Type
 - **Flash-based BSL (supports MSP430F5x and MSP430F6x)** TI provides BSL source code in BSL memory, but it is limited by storage space and has less flexibility.
 - **Main Memory BSL (Support all MSP430)** TI provides example code of Main Memory BSL for customers to develop a customized BSL, which is in main memory and has more flexibility but requires additional storage space.
- Product page: [Bootloader \(BSL\) for MSP low-power microcontrollers](#)

- Video
 - [MSP Bootloader \(BSL\) Overview](#)
 - [MSP Bootloader \(BSL\) Options](#)
- User's guide
 - [MSP430™ Flash Devices Bootloader \(BSL\) User's Guide](#)
 - [MSP430 FRAM Devices Bootloader \(BSL\) User's Guide](#)
- Application notes
 - [Creating a Custom Flash-Based Bootloader \(BSL\)](#)
 - [LaunchPad-Based MSP430 UART BSL Interface](#)
 - [MSP430 Bootloader With SimpleLink MCUs](#)
 - [MSP430 Bootloader With Sitara Embedded Linux Host](#)
 - [MSP430 Firmware Updates over I2C using Linux](#)
 - [MSPBoot – Main Memory Bootloader for MSP430 Microcontrollers](#)
 - [MSP430FRBoot – Main Memory Bootloader and Over-the-Air Updates](#)
 - [Over-the-Air \(OTA\) Update With the MSP430FR57xx](#)

4.4 Development Boards

Table 4-3 compares the development boards that support the MSP430 MCUs.

Table 4-3. Comparison of Development Boards

Features	LaunchPad	EVM board	Target socket board	TI reference design	BoosterPack
eZ-FET on board	✓	✓ / X			
Pinout	✓	✓ / X	✓		✓
Board on sale	✓	✓	✓		✓
Board features	Ease to use and cheap	Systematic solution	Socket on board	Systematic solution	Compatible with LaunchPad kits
Application	Learning or evaluating MSP430	Typical MSP430 application reference	Chip test or subsystem reference	End equipment reference	Quickly build a system with analog and digital devices

LaunchPad development kit ★: Low-cost MSP430 development boards developed by TI that integrate an onboard debugger. It has fewer peripheral devices but exposes most MSP430 pins. Different LaunchPad kits can be plugged together to develop a plentiful system. It is the first choice for developing MSP430 applications.

- Product page: [MSP430FR2355 LaunchPad kit](#)
- Product page: [MSP430FR2433 LaunchPad kit](#)
- Product page: [MSP430FR2311 LaunchPad kit](#)
- Product page: [MSP430FR4133 LaunchPad kit](#)
- Product page: [MSP430FR5994 LaunchPad kit](#)
- Product page: [MSP430FR6989 LaunchPad kit](#)
- Product page: [MSP430FR5969 LaunchPad kit](#)
- Product page: [MSP430F5529 LaunchPad kit](#)
- Product page: [MSP430G2x LaunchPad kit](#)
- Product page: [MSP430FR2476 LaunchPad kit](#)

Target socket board: Standalone socket target boards used to program and debug through the JTAG and BSL interfaces. There are no peripheral devices onboard but the board exposes all MSP430 pins. The main advantages for these boards is that all MSP430 MCUs are supported and the MSP430 MCU is removable.

- User's guide ★: [MSP430 Hardware Tools User's Guide](#)
- Product page: See the Design & Development tab of each [MSP430 product page](#).

EVM board: It is an evaluation board mainly developed for specific MSP430 applications, such as capacitive touch sensing, ultrasonic sensing, energy measurement, etc. It contains related documentation, user's guide, and hardware. It provides a reference for customers to develop typical MSP430 applications.

- Product list: [MSP430 EVM boards](#)

TI reference designs Developed for applications using MSP430 MCUs, such as energy measurement, power, motor control, and more. It contains full design resources and most are a reference for developing end equipment. It is very similar to EVM board, and the difference is that it is not available to purchase on [ti.com](#).

- Product page: [MSP430 ultra-low-power MCUs – Reference designs](#)

BoosterPack plug-in modules: A platform for learning and evaluating the analog or digital devices from TI. There are now has 53 types and almost covers all TI product series. The BoosterPack form factor is compatible with the TI LaunchPad™ ecosystem of hardware evaluation modules.

- Product list: [BOOSTXL series product list](#)
- User's guide: [Build Your Own LaunchPad™ or LaunchPad BoosterPack™ Development Tool](#)

5 MSP430 Application Resources

5.1 Device-Related Application Notes

This part lists all the application notes based on MSP430 MCUs and their peripherals.

- Coding, programming, and debugging
 - [Software Coding Techniques for MSP430™ MCUs](#)
 - [MSP Code Protection Features](#)
 - [Mixing C and Assembler With MSP430™ MCUs](#)
 - [Design Considerations When Using the MSP430 Graphics Library](#)
 - [Optimizing C Code for Size With MSP430 MCUs: Tips and Tricks](#)
- Oscillator
 - [MSP430 32-kHz Crystal Oscillators](#)
 - [MSP430 LFXT1 Oscillator Accuracy](#)
- ADC

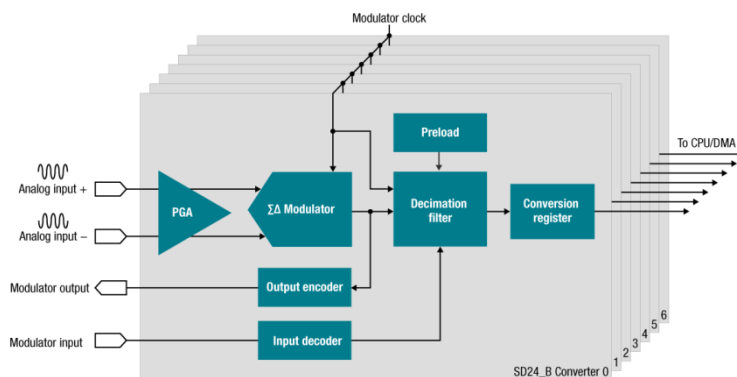

Figure 5-1. 7-Channel Sigma-Delta ADC Diagram

- [A Glossary of Analog-to-Digital Specifications and Performance Characteristics](#)
- [ADC Wake and Transmit on Threshold Using MSP430™ MCUs](#)
- [Designing With the MSP430FR4xx and MSP430FR2xx ADC](#)
- [Designing With the MSP430FR58xx, FR59xx, FR68xx, and FR69xx ADC](#)
- [General Oversampling of MSP ADCs for Higher Resolution](#)
- [High-Speed, Analog-to-Digital Converter Basics](#)
- [How delta-sigma ADCs work, Part 1](#)
- [How delta-sigma ADCs work, Part 2](#)
- [Implementing a Thermocouple Interface With ADC12_A](#)
- [Low-Power Battery Voltage Measurement With MSP430FR MCU On-Chip VREF and ADC](#)
- [Oversampling the ADC12 for Higher Resolution](#)
- Communication
 - [Understanding the I2C Bus](#)
 - [SMBus Compatibility With an I2C Device](#)
 - [Implementing a UART Function with the 8-bit Interval Timer/Counter](#)
 - [SPI I/O Expander Using Low-Memory MSP430™ MCUs](#)
 - [UART Software Controlled RGB LED Color Mixing With MSP430™ MCUs](#)
 - [UART-to-I2C Bridge Using Low-Memory MSP430™ MCUs](#)
 - [UART-to-SPI Bridge Using Low-Memory MSP430™ MCUs](#)

- [UART-to-UART Bridge Using Low-Memory MSP430™ MCUs](#)
- [Enabling Low-Power Windows 8 HID Over I2C Applications Using MSP430 MCUs](#)
- [Implementing SMBus Using MSP430 Hardware I2C](#)
- [Software I2C on MSP430 MCUs](#)
- [Solutions to Common eUSCI and USCI Serial Communication Issues on MSP430 MCUs](#)
- [Using the USCI I2C Master](#)
- **FRAM**
 - [FRAM FAQ](#)
 - [EEPROM Emulation Using Low Memory MSP430™ FRAM MCUs](#)
 - [Maximizing Write Speed on the MSP430™ FRAM](#)
 - [MSP430 FRAM Quality and Reliability](#)
 - [MSP430 FRAM Technology – How To and Best Practices](#)
 - [Low-Power FRAM Microcontrollers and Their Applications](#)
- **PWM**
 - [Analog Input to PWM Output Using the MSP430™ MCU Enhanced Comparator](#)
 - [Dual-Output 8-Bit PWM DAC Using Low-Memory MSP430™ MCUs](#)
 - [PWM DAC Using MSP430 High-Resolution Timer](#)
 - [Using PWM Timer_B as a DAC](#)
- **RTC**
 - [External RTC With Backup Memory Using a Low-Memory MSP430™ MCU](#)
 - [Simple RTC-Based System Wake-up Controller Using MSP430™ MCUs](#)
 - [ULP Temperature-Compensated RTC on MSP430F6736](#)
 - [Using the MSP430 RTC_B Module With Battery Backup Supply](#)
 - [Using the Real-Time-Clock Library](#)
- **Timer**
 - [External Programmable Watchdog Timer Using MSP430™ MCUs](#)
 - [Multiple Time Bases on a Single MSP430 Timer Module](#)
 - [Using the MSP430 Timer_D Module in Hi-Resolution Mode](#)
- **Smart analog combo(SAC) Configurable Op-Amp + Programmable gain(PGA) + 12-bit DAC**

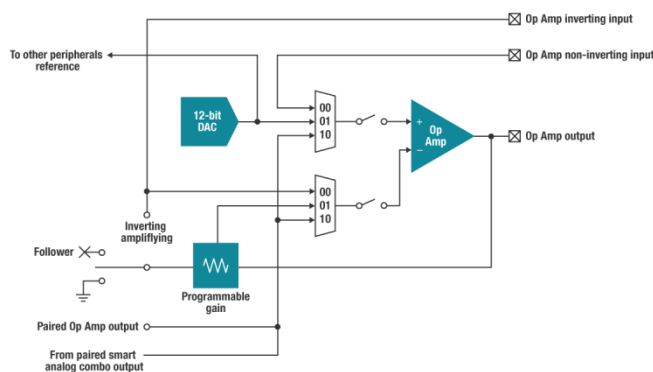

Figure 5-2. Smart Analog Combo Diagram

- [Half-wave rectifier circuit with MSP430 smart analog combo](#)
- [High-side current-sensing circuit design with MSP430 smart analog combo](#)
- [How to Use the Smart Analog Combo and Transimpedance Amplifier on MSP430FR2311](#)
- [How to Use the Smart Analog Combo in MSP430™ MCUs](#)
- [Low-noise long-range PIR sensor conditioner circuit MSP430 smart analog combo](#)
- [Low-side bidirectional current sensing circuit with MSP430™ smart analog combo](#)

- Strain gauge bridge amplifier circuit with MSP430 smart analog combo
- Temperature Sensing NTC Circuit With MSP430 Smart Analog Combo
- Transimpedance amplifier circuit with MSP430 smart analog combo
- Single-supply low-side unidirectional current-sensing circuit with MSP430 SAC
- Low-energy accelerator (LEA) Hardware engine designed for operations that involve vector-based signal processing without CPU intervention.

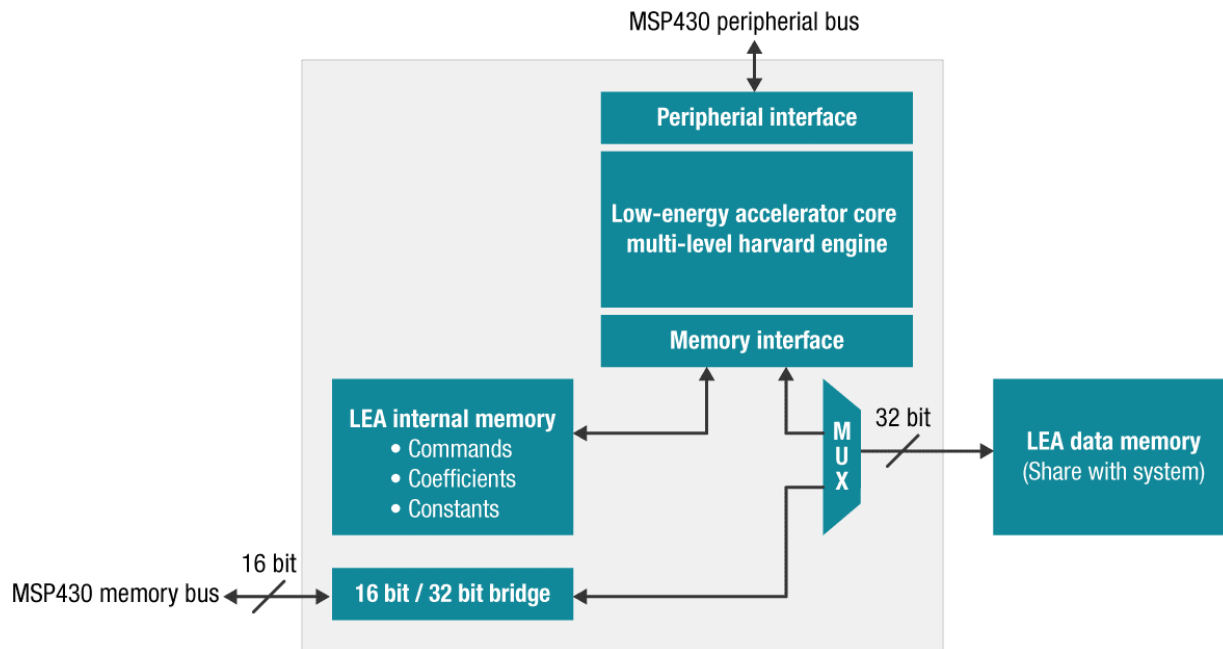

Figure 5-3. Low-Energy Accelerator Diagram

- Benchmarking the Signal Processing Capabilities of the Low-Energy Accelerator
- Low-Energy Accelerator (LEA) Frequently Asked Questions (FAQ)
- LCD
 - Designing With MSP430™ MCUs and Segment LCDs (includes the comparison between different LCD peripherals)
 - Driving Large LCDs with LCD Peripheral of the MSP430
 - Software Glass LCD Driver Based on MSP430 MCU
 - Use of Two MSP430s to Enhance Segment Lines for Larger LCDs
- Migrating from Flash to FRAM series
 - Code Porting From MSP430FR2000 to MSP430FR2311 MCUs
 - Migrating From MSP430FW42x Scan Interface to MSP430FR6x8x/FR5x8x ESI
 - Migrating from MSP430 F2xx and G2xx families to MSP430 FR4xx and FR2xx family
 - Migrating from the MSP430F2xx Family to the MSP430FR57xx Family
 - Migrating from the MSP430F2xx, G2xx Family to the MSP430FR58xx/FR59xx/68xx/69xx
 - Migrating From MSP430F4xx Family to MSP430FR58xx/FR59xx/FR68xx/FR69xx Family
 - Migrating from the MSP430F4xx to Family to the MSP430FR4xx Family
 - Migrating from the MSP430F5xx, F6xx Family to the MSP430FR58xx/FR59xx/68xx Family
 - Migrating from the USCI Module to the eUSCI Module
 - Migration from MSP430 FR58xx, FR59xx, and FR6xx to FR4xx and FR2xx

5.2 System-Level Solutions

The following three sections describe system-level solutions provided by TI:

- Typical MSP430 Reference Designs introduces the target applications for MSP430 MCUs. These designs include GUIs and other materials.
- TI Reference Designs lists other reference designs for many applications.
- System-Related Application Notes lists designs that are described in application notes. These designs include a wide range of applications.

5.2.1 Typical MSP430 Reference Designs

5.2.1.1 Capacitive Touch Sensing

This technology provides a low-power capacitive touch solution, which supports buttons, sliders, wheels and proximity. For touchpad materials, it supports metal, glass, plastic, etc. It is mostly used to improve the aesthetics and reliability of human-computer interaction.

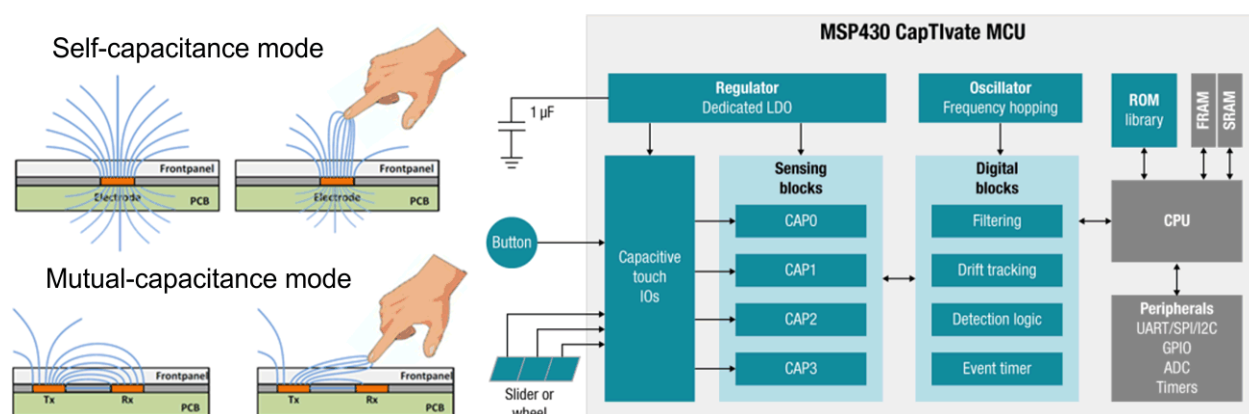

Figure 5-4. Capacitive Touch Sensing Diagram

- Product page: [CapTIvate™ MCUs: Easiest to use capacitive touch solutions](#)
- GUI product page: [CapTIvate™ Design Center GUI](#)
- User's guides ★
 - [CapTIvate™ Technology Guide](#)
- Video series: [CapTIvate™ Technology Training Series](#)
- Design flow guides ★
 - [Capacitive Touch Design Flow for MSP430™ MCUs With CapTIvate™ Technology](#)
- EVM and other boards available:
 - [CAPTIVATE-PGMR](#) (eZ-FET™ Programmer/debugger)
 - [CAPTIVATE-FR2676](#) (MSP430FR2676 Target MCU module)
 - [CAPTIVATE-FR2633](#) (MSP430FR2633 Target MCU module)
 - [BOOSTXL-CAPKEYPAD](#) (MSP430FR2522 + Mutual Capacitive HMI Demo)
 - [EVM430-CAPMINI](#) (MSP430FR2512 + Self capacitance Demo)
 - [CAPTIVATE-ISO](#) (Program and Communication Isolator)
 - [CAPTIVATE-BSWP](#) (Self capacitance HMI demo panel)
 - [CAPTIVATE-PHONE](#) (Mutual capacitance HMI demo panel)
 - [CAPTIVATE-METAL](#) (Metal Touch HMI demo panel)
 - [CAPTIVATE-EMC](#) (Electromagnetic compatibility performance evaluation)
- Application notes
 - [Enabling noise tolerant capacitive touch HMIs with MSP CapTIvate™ technology](#)
 - [Automating Capacitive Touch Sensor PCB Design Using OpenSCAD Scripts](#)

- Capacitive Touch Gesture Software and Tuning
- Capacitive Touch Hardware Design Guide
- Capacitive Touch Through Metal Using MSP430™ MCUs With CapTIvate™ Technology
- Sensitivity, SNR, and design margin in capacitive touch applications
- TI reference designs
 - 64 Button Capacitive Touch Panel With CapTIvate Technology Design Guide
 - Access Control Panel With BLE, Cap Touch, and Software Integration Ref Design
 - Capacitive Touch Thermostat User Interface Design Guide
 - Capacitive-Based Liquid Level Sensing Sensor Reference Design
 - CapTIvate™ E-Lock Design Guide
 - Gesture-Based Capacitive Touch Speaker Interface Reference Design
 - Liquid Tolerant Capacitive Touch Keypad Reference Design
 - MSP432 With MSP430 Microcontroller With CapTIvate Technology, Haptics, and LCD
 - Noise Tolerant Capacitive Touch Human Machine Interfaces Design Guide
 - Touch Remote Control Reference Design With CapTIvate Technology
 - Low Power Touch Through Glass Design Guide
 - Touch Through Glass With Sharp® LCD Design Guide

5.2.1.2 Ultrasonic Sensing

This technology is designed for high-precision liquid and gas flow measurement applications. It can use in water or gas meters, level sensing, leakage detection, anemometer, and more.

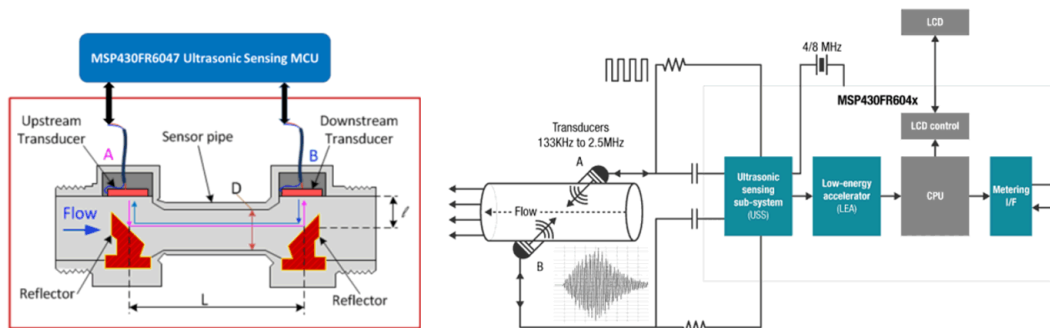

Figure 5-5. Ultrasonic Sensing Diagram

- Product page: [Ultra-low-power SoCs for water, gas and heat meters](#)
- GUI product page: [MSP430 MCUs Ultrasonic Sensing Design Center](#)
- Video series
 - [Ultrasonic sensing for water flow meters](#)
 - [Ultrasonic sensing for gas flow meters](#)
- EVM boards ★
 - [EVM430-FR6047](#)(For water flow metering sensing)
 - [EVM430-FR6043](#)(For water and gas metering sensing)
- Application notes
 - [Frequently asked questions \(FAQ\) on ultrasonic sensing technology](#)
 - [How to Synchronize the MSP430FR6047 Clock System Domains With the USS Oscillator](#)
 - [Waveform capture based ultrasonic sensing water flow metering technology](#)
 - [Ultrasonic sensing of gas flow](#)
 - [MSP430FR6043-based ultrasonic gas flow meter quick start guide](#)
 - [MSP430FR6047-based ultrasonic water flow meter quick start guide](#)
 - [Ultrasonic sensing solution submodules overview](#)

- Ultrasonic Transducer [Selection](#) for Gas Metering
- [High Resolution Ultrasonic Liquid Level Sensing](#)
- TI reference designs
 - [Optimized ultrasonic sensing metrology reference design for water flow measurement](#)
 - [Ultrasonic sensing subsystem reference design for gas flow measurement](#)

5.2.1.3 Energy Measurement

This technology can perform high precision current, voltage, active and reactive power measurements. It is mainly used in electric meters and submetering, and supports CT, Rogowski coil, and shunt current sensors.

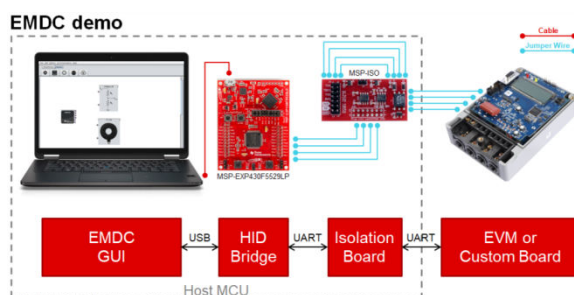

Figure 5-6. Energy Measurement System Connection

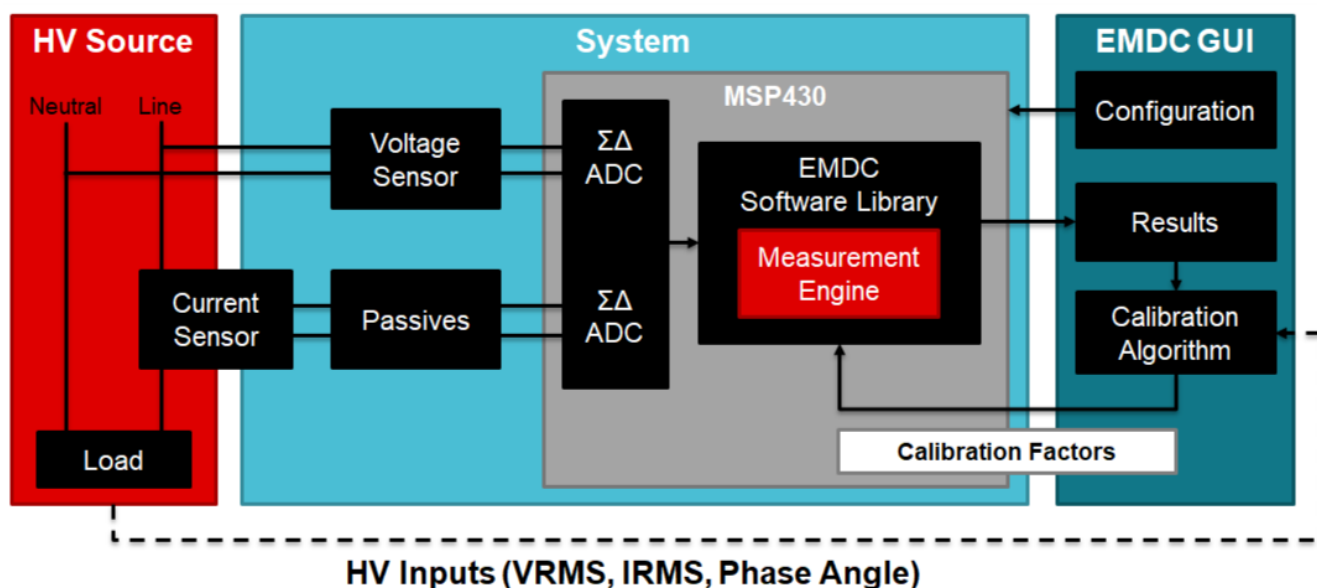

Figure 5-7. Energy Measurement Diagram

- GUI product page: [Energy Measurement Design Center for MSP430 MCUs](#)
- User's guide ★: [Energy Measurement Technology Guide](#)
- Video series: [Energy Measurement Design Center for MSP430 MCUs: Training Series](#)
- EVM boards (to download the GUI for these three EVMs, visit the [MSP-EM-DESIGN-CENTER product page](#))
 - [EVM430-i2040S](#) (Single-phase or submetering energy measurement)
 - [EVM430-F6736](#) (Single-phase meter: Class 0.2 Accuracy)
 - [EVM430-F6779](#) (Three-phase meter: Class 0.2 Accuracy)
- Application notes
 - [Implementation of a One- or Two-Phase Electronic Watt-Hour Meter Using the MSP430i20xx](#)
 - [Differences Between MSP430F67xx and MSP430F67xxA Devices](#)

- TI reference designs
 - [ULP Temperature Compensated RTC on MSP430F6736 Design Guide](#)
 - [Single-Phase AC and DC Power Monitor with Wire Resistance and EMI Capacitor Compensation](#)
 - [Single-Phase Electric Meter With Isolated Energy Measurement](#)
 - [Three Phase Rogowski Coil Based E-Meter Solution](#)
 - [One-Phase Metrology with Enhanced ESD Protection Reference Design](#)
 - [Class 0.5 Three-Phase Smart Meter Reference Design](#)
 - [Battery Management and Auxiliary Power Supply Options for e-Meters Design Guide](#)
 - [Three-Outlet Smart Power Strip Design Guide](#)
 - [Implementing Wi-Fi Connectivity in a Smart Electric Meter](#)

5.2.1.4 USB Integration

MSP430 MCUs include an on-chip USB 2.0 module on several subfamilies. Combined with the MSP430 USB Developers Package, the USB development will be simple.

- GUI product page: [MSP430 USB Developers Package](#)
- User's guide ★: [Starting a USB Design Using MSP430 MCUs](#)
- Application notes
 - [Implementing Wi-Fi Connectivity in a Smart Electric Meter](#)
 - [Android Applications With MSP430 USB on Mobile Devices](#)
 - [USB Keyboard Using MSP430 Microcontrollers](#)
 - [USB Field Firmware Updates on MSP430 MCUs](#)

5.2.2 TI Reference Designs

- [BOOST-IR Infrared \(IR\) BoosterPack™ Plug-in Module User's Guide](#)
- [Level 1 and Level 2 Electric Vehicle Service Equipment \(EVSE\) Design Guide](#)
- [10s battery monitoring, balancing, and comp protection, 50A discharge ref design](#)
- [4-mA to 20-mA Current Loop Transmitter Design Guide](#)
- [10-uA to 100-mA 0.05%-Error High-Side Current Sensing Design Guide](#)
- [Power over Ethernet \(PoE\) reference design for industrial gateways](#)
- [MSP430FR2311 IR Reflection-Sensing Subsystem Design Guide](#)
- [4- to 20-mA Loop-Powered RTD Temperature Transmitter Reference Design](#)
- [Multiparameter Biosignal Monitor Design Guide](#)
- [TIDM-NFC-RW Design Guide](#)
- [Ultra-Low Power Blood Pressure and Heart Rate Monitor Design Guide](#)
- [Highly Integrated, 4½ Digit, Low Power Handheld DMM Platform Reference Design](#)
- [MSP430 Software RGB LED Control Design Guide](#)
- [ADAS Multi-Sensor Hub Design With Quad 4-Gbps FPD-Link III, Dual CSI-2 Output](#)
- [0-A to 1-A Single-Supply Low-Side Current-Sensing Solution Design Guide](#)
- [Air Quality Sensor Design Guide](#)
- [SMBus Design Using MSP430 Design Guide](#)
- [EEPROM Emulation and Sensing With MSP FRAM Microcontrollers Reference Design](#)
- [Inductive Proximity Sensing Design Guide](#)
- [Wi-Fi Enabled Level 1 Level 2 Electric Vehicle Service Equipment Design Guide](#)
- [TEC driver reference design for 3.3-V inputs](#)
- [Case Tamper Detection Reference Design Using Inductive Sensing](#)
- [ADAS 8-Channel Sensor Fusion Hub Ref Design With Two 4-Gbps Quad Deserializer](#)
- [Smart Solenoid Driver With Predictive Maintenance Reference Design](#)
- [ESI + LDC Inductive Linear Position Sensing Design Guide](#)
- [Voice Band Audio Playback Using a PWM DAC Design Guide](#)

- [Memory Emulation Using 1-Wire Communication Protocol Design Guide](#)
- [+/-1A Single-Supply Low-Side Current Sensing Solution Design Guide](#)
- [IO-Link Firmware Update Reference Design Leveraging MSP430™ FRAM Technology](#)
- [Output Current Sensing and Limit, Plug-in Detection in Power Bank Design Guide](#)
- [NFC Authentication for an EV Charging Station \(Pile\) Reference Design](#)
- [KNX Thermostat TI Design Guide](#)
- [Temperature Transmitter on Single Chip Mixed-Signal MCU](#)
- [Data Collector for wM-Bus T-/C-Modes and DSSS-Coded Long-Range Mode Design Guide](#)
- [Thermostat Implementation With MSP430FR4xx Design Guide](#)
- [Remote Controller of Air Conditioner Using MSP430 Design Guide](#)
- [Filtering and Signal Processing Ref Design Using MSP430 FRAM Microcontroller](#)
- [MSP430 Low Power Orientation Tracker Design Guide](#)
- [Data Isolation for Loop-Powered Applications Design Guide](#)
- [MSP-EXP430FR6989 & FRAM to Enable Compute Thru Power Loss Utility Design Guide](#)
- [QVGA 3D Graphics on MSP430 Microcontrollers Design Guide](#)
- [18-V/400-W 98% Efficient Compact Brushless DC Motor Drive Design Guide](#)
- [12V to 24V, 27A Brushed DC Motor Reference Design](#)
- [Reference Design for Wireless Condition Monitor for Motors and Pumps](#)
- [24V/36W BLDC Motor Driver Reference Design With Close-Loop Speed Control](#)
- [Driving Three-Phase Stepper Motor With BLDC Motor Driver Reference Design](#)
- [1-PWM Brushless DC Motor Control TI Reference Design](#)
- [Unipolar Stepper Motor Driver Using a Bipolar Stepper Controller Design Guide](#)
- [Wireless Motor Monitor \(WMM\) Design Guide](#)
- [Low-Power Micro Stepper Motor Driver Using FRAM MCU Design Guide](#)
- [Integrated Sensored BLDC Motor Controller Reference Design](#)
- [Dual High Resolution Micro-Stepping Driver](#)
- [10.8-V/250-W, 97% Efficient, Compact BLDC Motor Drive With Stall Current Limit](#)
- [Filtering and Signal Processing Reference Design Using MSP430 FRAM Microcontroller](#)
- [12-V, 15-W Power Limit, Single Driver-Based Stepper, Brushed DC and Actuator Drive Reference Design](#)

5.2.3 System-Related Application Notes

- [Enhance simple analog and digital functions for \\$0.25](#)
- [CRC Implementation with MSP430 MCUs](#)
- [Digital Addressable Lighting Interface \(DALI\) Using MSP430 Value Line](#)
- [EKG-Based Heart-Rate Monitor Implementation Using the MSP430G2xx LaunchPad Kit](#)
- [Implementing a Direct Thermocouple Interface With the MSP430F4xx and ADS1240](#)
- [Implementing a Single-Chip Thermocouple Interface with the MSP430F42xA MCUs](#)
- [Implementing An Ultra-Low-Power Keypad Interface With MSP430 MCUs](#)
- [Implementing An Ultra-Low-Power Thermostat With Slope ADC](#)
- [Implementing IrDA With MSP430 MCUs](#)
- [Infrared Remote Control Implementation With MSP430FR4xx](#)
- [Fuzzy Logic Motor Control With MSP430 MCUs](#)
- [Servo Motor Controller Using MSP430™ MCUs](#)
- [Stepper Motor Control Using MSP430™ MCUs](#)
- [1.8V – 5.5V Input, High-Efficiency DCDC Converter Reference Design for MSP430](#)
- [1-Wire Enumeration](#)
- [7-Segment LED Stopwatch Using Low-Memory MSP430™ MCUs](#)
- [A Simple Glass-Breakage Detector Using an MSP430 MCU](#)
- [A Single-Chip Pulsoximeter Design Using the MSP430](#)

- [Calling Convention and ABI Changes in MSP GCC](#)
- [Dual-Ray Smoke Detector Design With MSP430FR2355 MCUs](#)
- [Getting Started With EEMBC ULPBench on MSP-EXP430FR5969](#)
- [Heart-Rate and EKG Monitor Using the MSP430FG439](#)
- [Hysteresis Comparator With UART Using Low-Memory MSP430™ FRAM MCUs](#)
- [Interfacing an MSP430 MCU and a TMP100 Temperature Sensor](#)
- [Interfacing MSP430™ MCUs With MMC or SD Flash Memory Cards](#)
- [Interfacing the 3-V MSP430 MCU to 5-V Circuits](#)
- [LC Sensor Rotation Detection With MSP430 Extended Scan Interface \(ESI\)](#)
- [Li-Ion Battery Charger Solution Using an MSP430™ MCU](#)
- [Low -Power Hex Keypad Using MSP430™ MCUs](#)
- [Method to Select the Value of LC Sensor for MSP430 Extended Scan Interface \(ESI\)](#)
- [MSP430 Advanced Power Optimizations: ULP Advisor SW and EnergyTrace Technology](#)
- [MSP430 Based Lithium-Ion Polymer Battery Charging and Gauging Solution Using USB](#)
- [MSP430 Embedded Application Binary Interface](#)
- [MSP430's Analog Combo Enables True Single-Chip Pulse Oximeter Designs](#)
- [MSP430F42xA Single-Chip Weight Scale](#)
- [Multi-Cell Li-Ion Battery Management System Using MSP430F5529 and bq76PL536](#)
- [Multi-Function Reset Controller With Low-Memory MSP430™ MCUs](#)
- [Nine-Axis Sensor Fusion Using Direction Cosine Matrix Algorithm on MSP430F5xx](#)
- [Powering the MSP430 from a High Voltage Input using the TPS62122](#)
- [Programmable Clock Source Using MSP430™ MCUs](#)
- [Programmable Frequency Locked Loop Using MSP430™ MCUs](#)
- [Programmable System Wake-up Controller Using MSP430™ MCUs](#)
- [Quadrature Encoder Position Counter With MSP430™ MCUs](#)
- [Random Number Generation Using MSP430FR59xx and MSP430FR69xx Microcontrollers](#)
- [Random Number Generation Using MSP430™ MCUs](#)
- [Revised Pulse Oximeter Design Using the MSP430](#)
- [Simple Power Sequencer Using MSP430™ MCUs](#)
- [Single-Slope Analog-to-Digital Conversion Technique Using MSP430™ MCUs](#)
- [Single-Wire Communication Host With MSP430™ MCUs](#)
- [Tamper Detection Using Low-Memory MSP430™ MCUs](#)
- [Using MSP on KNX Systems Application note](#)
- [Using power solutions to extend battery life in MSP430\(TM\) MCU applications](#)
- [Using the MSP430FR6047 Wireless M-Bus Serial Library for Metering Applications](#)
- [VLO Calibration on the MSP430FR4xx and MSP430FR2xx Family](#)
- [Voltage Monitor With a Timestamp Using a Low-Memory MSP430™ MCU](#)
- [Wave Digital Filtering Using an MSP430 MCU](#)
- [Wide-Vin Battery-Charger Using SMBus MSP430 MCUs and bq Fuel Gauges](#)
- [High Resolution Ultrasonic Liquid Level Sensing](#)

5.3 Encryption and Security

Implementations of the AES, DES, TDES, and SHA-2: Used for devices without hardware acceleration for these algorithms.

- [User's guide: C Implementation of Cryptographic Algorithms](#)
- [Algorithms](#)
 - [Advanced Encryption Standard](#)
 - [Data Encryption Standard](#)

- [Secure Hash Standard](#)

Secure firmware updates: Some applications need secure firmware updates. The following has been made available for these scenarios.

- Application notes: [Secure In-Field Firmware Updates for MSP MCUs](#)
- Crypto-Bootloader
 - User's guide: [Crypto-Bootloader \(CryptoBSL\) for MSP430FR59xx and MSP430FR69xx MCUs User Guide](#)
 - Application notes: [Crypto-Bootloader - Secure In-Field Firmware Updates for Ultra-Low Power MCUs](#)
 - Firmware: [Crypto_Bootloader](#)

IEC 60730 Safety Applications

- User's guide: [Safety Manual for MSP430G2xx, F5xx, and FR57xx in IEC 60730 Safety Applications](#)

6 TI Quality Introduction

6.1 TI Quality Policy

Quality is foundational to achieving TI business objectives. TI is committed to satisfying applicable requirements and providing quality products to customers around the world by

- Encouraging and expecting the creative involvement of every Tler
- Listening to our customers
- Continuously improving and innovating our products, processes and services

6.2 TI Product Reliability

TI is committed to delivering high quality and reliable semiconductor solutions that meet customers' needs. The [TI Product Reliability page](#) provides quality and reliability information and data including the following:

- **Qualification summary**★: Used to search reliability data of related devices. Representative data summary of the material sets, processes, and manufacturing sites used by the device family.
- **Reliability testing**: Listed the various types of testing that TI conducts for reliability of its products.
- **DPPM/FIT/MTBF estimator**: The DPPM/FIT/MTBF estimator search tool allows you to find generic data based on technology groupings to estimate these typical questions and shows conditions under which the rates were derived.
- **Ongoing reliability monitoring**: The search tool of ongoing reliability monitor (ORM) program will provide the quarterly ORM report by wafer fab process or device package family.

6.3 TI Packaging Introduction

MSP430 MCUs are available in various packages to support customers' application needs – visit the [TI Packaging Introduction page](#). On TI.com, select the **Quality & reliability** → **Additional information** → **Packaging information** path to find package considerations including package size, reliability, and performance expectations. Visit the [SMT & packaging application notes page](#) for SMTA recommendations on a variety of packaging topics. In addition, the [Ultra Librarian software tool](#) can aid on layout design on specific package.

6.4 Customer Returns

Customer satisfaction is important to TI, and customer returns are handled with care and urgency. To ensure timely resolution of customer concerns, TI has an established customer return process for customers who wish to return parts.

The [Customer returns page](#) provides detailed guidelines for returning material to TI.

[Table 6-1](#) lists general debugging documents to support the isolation of possible problems with timely solutions.

Table 6-1. MSP430 Quality Related Resources

Item	Document
Errata	See the device-specific errata for the MCU silicon revision
Troubleshooting guide	Troubleshooting Guidelines for MSP Devices (TI website)
IC ESD	Electrostatic Discharge (ESD) (TI website)
System ESD	website
Programming	MSP430™ Programming With the JTAG Interface (TI website)
EOS introduction	Understanding Electrical Overstress - EOS (Whitepaper 4) (Industry Council website)
Others	ESD Diode Current Specification (TI website) MSP430™ System-Level ESD Considerations (TI website) Debugging Flash Issues on the MSP430 Family of Microcontrollers (TI website) Understanding MSP430 Flash Data Retention (TI website)

7 Revision History

NOTE: Page numbers for previous revisions may differ from page numbers in the current version.

DATE	REVISION	NOTES
October 2020	*	Initial Release

IMPORTANT NOTICE AND DISCLAIMER

TI PROVIDES TECHNICAL AND RELIABILITY DATA (INCLUDING DATASHEETS), DESIGN RESOURCES (INCLUDING REFERENCE DESIGNS), APPLICATION OR OTHER DESIGN ADVICE, WEB TOOLS, SAFETY INFORMATION, AND OTHER RESOURCES "AS IS" AND WITH ALL FAULTS, AND DISCLAIMS ALL WARRANTIES, EXPRESS AND IMPLIED, INCLUDING WITHOUT LIMITATION ANY IMPLIED WARRANTIES OF MERCHANTABILITY, FITNESS FOR A PARTICULAR PURPOSE OR NON-INFRINGEMENT OF THIRD PARTY INTELLECTUAL PROPERTY RIGHTS.

These resources are intended for skilled developers designing with TI products. You are solely responsible for (1) selecting the appropriate TI products for your application, (2) designing, validating and testing your application, and (3) ensuring your application meets applicable standards, and any other safety, security, or other requirements. These resources are subject to change without notice. TI grants you permission to use these resources only for development of an application that uses the TI products described in the resource. Other reproduction and display of these resources is prohibited. No license is granted to any other TI intellectual property right or to any third party intellectual property right. TI disclaims responsibility for, and you will fully indemnify TI and its representatives against, any claims, damages, costs, losses, and liabilities arising out of your use of these resources.

TI's products are provided subject to TI's Terms of Sale (www.ti.com/legal/termsofsale.html) or other applicable terms available either on ti.com or provided in conjunction with such TI products. TI's provision of these resources does not expand or otherwise alter TI's applicable warranties or warranty disclaimers for TI products.

Mailing Address: Texas Instruments, Post Office Box 655303, Dallas, Texas 75265
Copyright © 2020, Texas Instruments Incorporated