

BOOSTXL-EDUMKII Educational BoosterPack™ Plug-in Module Mark II

The **BOOSTXL-EDUMKII** BoosterPack™ (see [Figure 1](#)) kit is an easy-to-use plug-in module that offers a high level of integration for developers to quickly add to LaunchPad™ development kit designs. Various analog and digital inputs and outputs are at your disposal including an analog joystick, environmental and motion sensors, RGB LED, microphone, buzzer, color LCD display, and more.

This BoosterPack plug-in module was developed with Energia in mind. Energia is an open-source community-developed coding environment, which is supported by a robust framework of intuitive APIs and easy-to-use software libraries for rapid firmware development. TI recommends Energia v12 or later. Learn more about Energia at www.energia.nu.

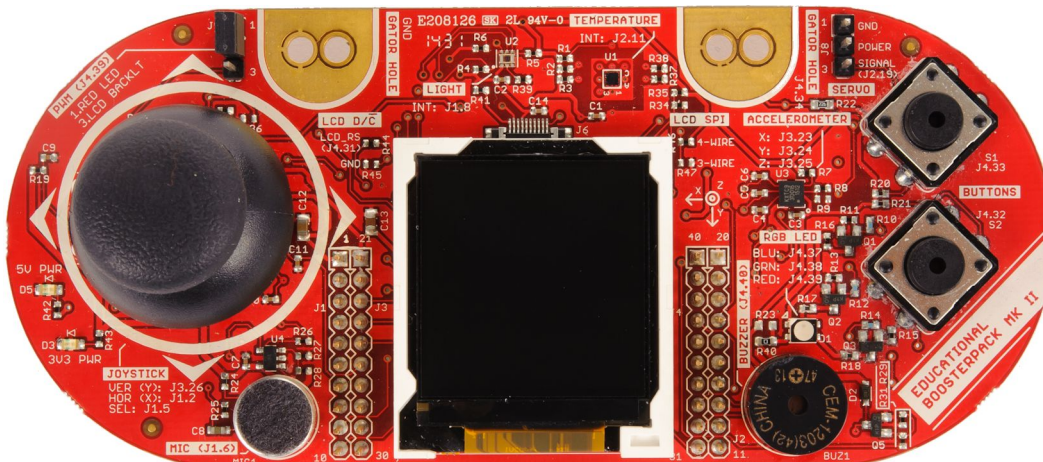

Figure 1. BOOSTXL-EDUMKII BoosterPack Plug-in Module

Contents

1	Getting Started	3
2	Hardware.....	4
3	Software Examples	9
4	Additional Resources	15
5	Schematics.....	16

List of Figures

1	BOOSTXL-EDUMKII BoosterPack Plug-in Module	1
2	BOOSTXL-EDUMKII Overview	4
3	BoosterPack Plug-in Module Pinout.....	5
4	3-Axis Analog Accelerometer.....	10
5	2-Axis Analog Joystick With Digital Input	11
6	OPT3001 Ambient Light Sensor	12
7	TMP006 Infrared Contactless Temperature Sensor	13
8	Microphone.....	14
9	TI Drivers Software Examples in TI Resource Explorer	15
10	Schematics (1 of 2)	17
11	Schematics (2 of 2)	18

List of Tables

1	OPT3001 Pinout	5
2	TMP006 Pinout.....	6
3	Servo Motor Connector Pinout.....	6
4	3-Axis Accelerometer Pinout	6
5	RGB LED Pinout.....	7
6	Piezo Buzzer Pinout.....	7
7	Color LCD Pinout	7
8	RGB LED Pinout.....	8
9	Joystick Pinout	8
10	User Pushbuttons Pinout	8
11	Hardware Change Log.....	9
12	Software Examples	9
13	IDE Minimum Requirements for MSP-EXP432P401R.....	9
14	Source File and Folders	10
15	Source File and Folders	11
16	Source File and Folders	12
17	Source File and Folders	13
18	Source File and Folders	14

Trademarks

BoosterPack, LaunchPad, SimpleLink, MSP432, Code Composer Studio, E2E are trademarks of Texas Instruments.

Keil, μ Vision are registered trademarks of ARM Limited.

Bluetooth is a registered trademark of Bluetooth SIG.

IAR Embedded Workbench is a registered trademark of IAR Systems.

Wi-Fi is a registered trademark of Wi-Fi Alliance.

All other trademarks are the property of their respective owners.

1 Getting Started

1.1 Introduction

The BOOSTXL-EDUMKII BoosterPack plug-in module is an easy-to-use plug-in module that offers a high level of integration for developers to quickly add to LaunchPad development kit designs. Various analog and digital inputs and outputs are at your disposal including an analog joystick, environmental and motion sensors, RGB LED, microphone, buzzer, color LCD display, and more.

This BoosterPack plug-in module was developed with Energia in mind. Energia is an open source, community developed coding environment, which is supported by a robust framework of intuitive APIs and easy-to-use software libraries for rapid firmware development. TI recommends Energia v12 or later. Learn more about Energia at www.energia.nu.

1.2 Key Features

- TI OPT3001 light sensor
- TI TMP006 temperature sensor
- Servo motor connector
- 3-axis accelerometer
- RGB multicolor LED
- Piezo buzzer
- Color 128x128 TFT LCD display
- Microphone
- 2-axis joystick with pushbutton
- User push buttons
- 40-pin BoosterPack plug-in module standard for use with any LaunchPad development kit

1.3 What's Included

1.3.1 Kit Contents

- 1 x BOOSTXL-EDUMKII BoosterPack plug-in module
- 1 x Quick Start Guide

1.3.2 Software Examples

- SimpleLink™ [MSP-EXP432P401R LaunchPad development kit](#) + BOOSTXL-EDUMKII demos (see [Section 3](#))
 - BOOSTXL-EDUMKII_Accelerometer_MSP432P401R
 - BOOSTXL-EDUMKII_JoyStick_MSP432P401R
 - BOOSTXL-EDUMKII_LightSensor_MSP432P401R
 - BOOSTXL-EDUMKII_Temperature_MSP432P401R
 - BOOSTXL-EDUMKII_MicrophoneFFT_MSP432P401R

1.4 Next Steps: Looking Into the Provided Code

After the EVM features have been explored, the fun can begin. It's time to open an integrated development environment (IDE) and start looking at the code examples. [Section 3](#) describes the example projects available to make it easy to understand the provided software. For more information on where to find and download an IDE, see [Section 4](#).

2 Hardware

Figure 2 is an overview of the BOOSTXL-EDUMKII hardware.

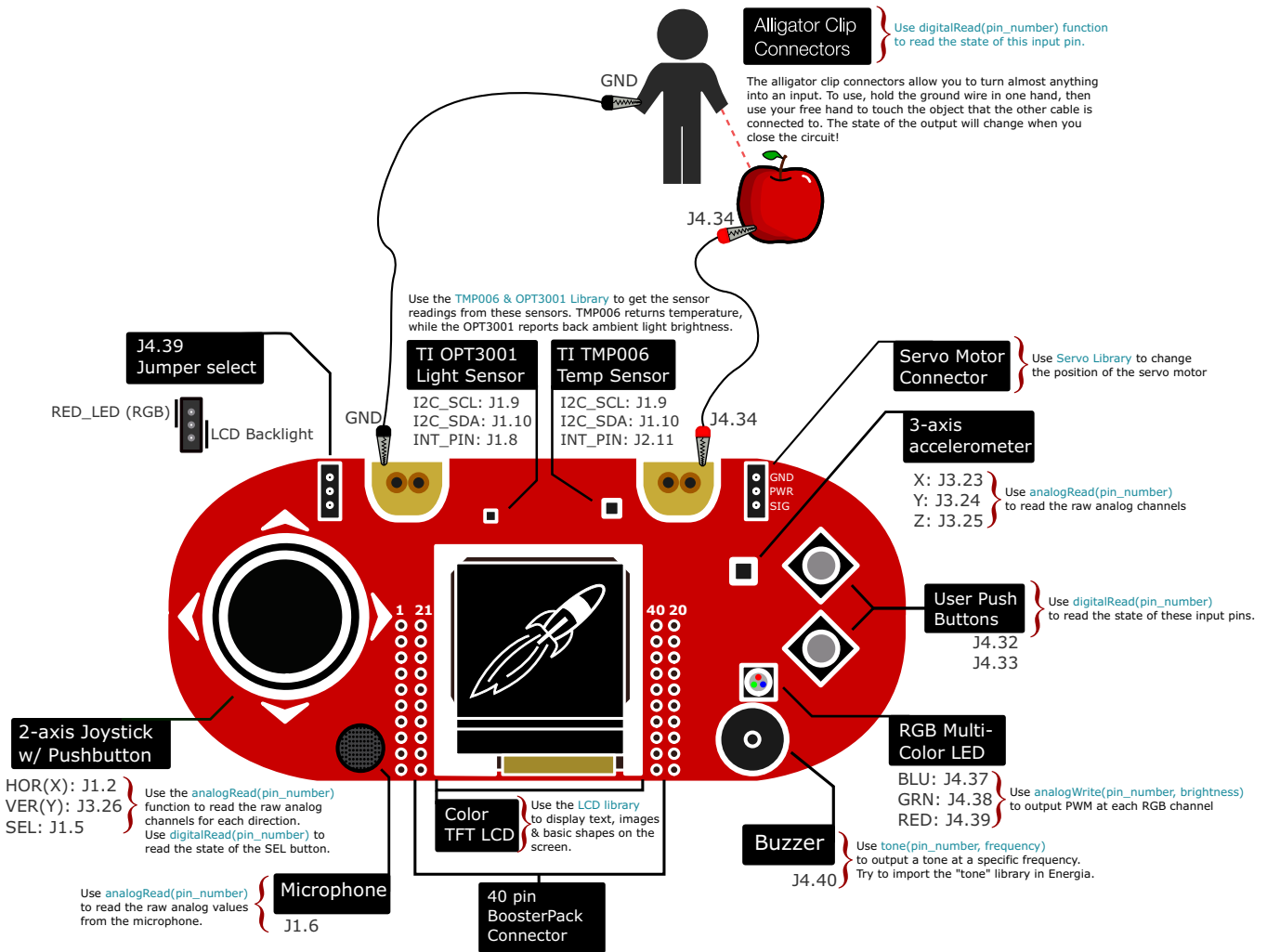

Figure 2. BOOSTXL-EDUMKII Overview

2.1 Hardware Features

2.1.1 BoosterPack Plug-in Module Pinout

The Educational BoosterPack plug-in module MKII adheres to the 40-pin LaunchPad development kit and BoosterPack plug-in module pinout standard (see Figure 3). A standard was created to aid compatibility between LaunchPad development kits and BoosterPack plug-in modules across the TI ecosystem.

Pinout Diagram for your BoosterPack

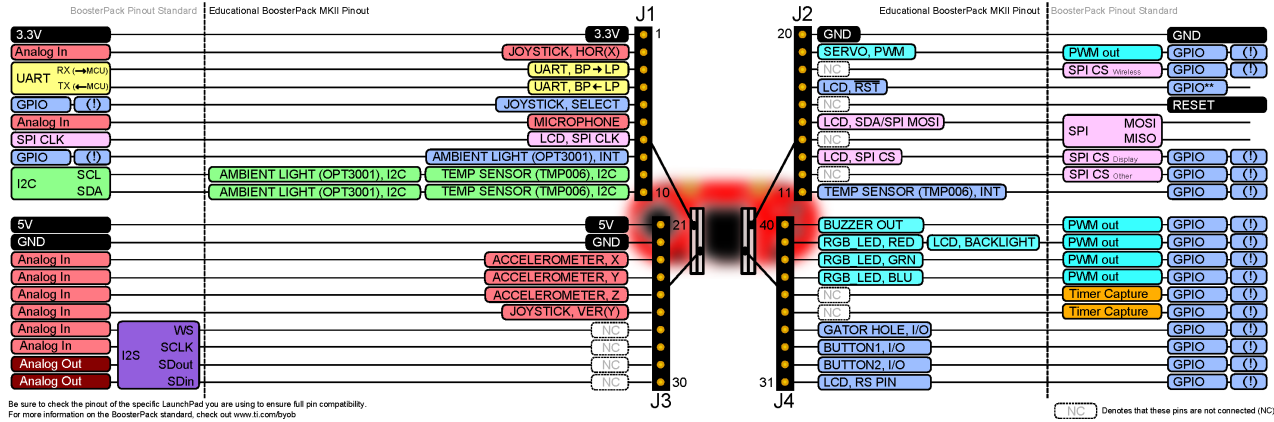

Figure 3. BoosterPack Plug-in Module Pinout

The 40-pin standard is compatible with the 20-pin standard that is used by other LaunchPad development kits like the MSP-EXP430G2. This allows for 20-pin LaunchPad development kits to be used with 40-pin BoosterPack plug-in modules with some limited functionality.

The BOOSTXL-EDUMKII supports BoosterPack plug-in module stacking with its male and female BoosterPack plug-in module headers. See how many BoosterPack plug-in modules you can stack onto your LaunchPad development kit to add more functionality like wireless and battery power.

More information about compatibility can also be found at <http://www.ti.com/launchpad>.

2.1.2 TI OPT3001 Light Sensor

The OPT3001 is a digital ambient light sensor (ALS) that measures the intensity of light as visible by the human eye. Covering the sensor with your finger or shining a flashlight on it will change the output of the OPT3001. The digital output is reported over an I²C- and SMBus-compatible, two-wire serial interface. The reference designator for the OPT3001 is U2.

More information on the OPT3001 light sensor can be found at <http://www.ti.com/product/opt3001>.

Table 1. OPT3001 Pinout

BoosterPack Plug-in Module Header Connection	Pin Function
J1.8	OPT3001 interrupt
J1.9 ⁽¹⁾	I ² C SCL
J1.10 ⁽¹⁾	I ² C SDA

⁽¹⁾ Pin is multiplexed with the I²C communication lines of the TMP006.

2.1.3 TI TMP006 Temperature Sensor

The TMP006 is a digital infrared (IR) thermopile contactless temperature sensor that measures the temperature of an object without being in direct contact. Placing your hand over the sensor increases the sensor output. The digital output is reported over an I²C- and SMBus-compatible two-wire serial interface. The reference designator for the TMP006 is U1.

More information on the TMP006 temperature sensor can be found at <http://www.ti.com/product/tmp006>.

Table 2. TMP006 Pinout

BoosterPack Plug-in Module Header Connection	Pin Function
J1.9 ⁽¹⁾	I ² C SCL
J1.10 ⁽¹⁾	I ² C SDA
J2.11	TMP006 Interrupt

⁽¹⁾ Pin is multiplexed with the I²C communication lines of the OPT3001.

2.1.4 Servo Motor Connector

The servo motor connector is a 3-pin header for the user to connect an external servo to be controlled. Users can connect a servo and control it through the application code. The reference designator for the servo motor connector is J8.

Table 3. Servo Motor Connector Pinout

BoosterPack Plug-in Module Header Connection	Pin Function
J2.19	Servo Signal

NOTE: This kit does not include a servo motor and the user must provide one.

2.1.5 3-Axis Accelerometer

The Kionix KXTC9-2050 is a 3-axis analog accelerometer that measures g-forces. Moving the board along the axes will change the analog signal generated by the accelerometer. The reference designator for the accelerometer is U3.

More information on the 3-axis accelerometer can be found at <http://www.kionix.com/product/KXTC9-2050>.

Table 4. 3-Axis Accelerometer Pinout

BoosterPack Plug-in Module Header Connection	Pin Function
J3.23	Accelerometer X-axis
J3.24	Accelerometer Y-axis
J3.25	Accelerometer Z-axis

2.1.6 RGB Multicolor LED

The Cree CLV1A-FKB RGB multicolor LED light output can make any color by mixing red, green, and blue. Each color channel can be individually modified by pulse width modulation (PWM) to achieve the desired color. The reference designator for the RGB LED is D1.

More information on the RGB multicolor LED can be found at <http://www.cree.com/LED-Components-and-Modules/Products/High-Brightness/SMD-Color/SMD-Full-Color>.

Table 5. RGB LED Pinout

BoosterPack Plug-in Module Header Connection	Pin Function
J4.37	Blue channel
J4.38	Green channel
J4.39 ⁽¹⁾	Red channel

⁽¹⁾ Pin is multiplexed with the LCD backlight pin through the jumper header J5.

2.1.7 Piezo Buzzer

The CUI CEM-1203(42) piezo buzzer can play various frequencies based on the user-provided PWM signal. You can even play different tones back to back to create a song. The reference designator for the piezo buzzer is BUZ1.

More information on the piezo buzzer can be found at [http://www.cui.com/product/components/buzzers/audio-transducers/magnetic/cem-1203\(42\)](http://www.cui.com/product/components/buzzers/audio-transducers/magnetic/cem-1203(42)).

Table 6. Piezo Buzzer Pinout

BoosterPack Plug-in Module Header Connection	Pin Function
J4.40	Buzzer input

2.1.8 Color 128x128-Pixel TFT LCD Display

The Crystalfontz CFAF128128B-0145T color 128x128-pixel TFT LCD supports display updates up to 20 frames per second (FPS) while only requiring a few lines to control the TFT LCD module through the SPI interface. This module has a color depth of 262K colors and a contrast ratio of 350. The reference designator for the color LCD is LCD1.

More information on the color LCD can be found at <https://www.crystalfontz.com/product/cfaf128128b0145t-graphical-tft-128x128-lcd-display-module>.

Table 7. Color LCD Pinout

BoosterPack Plug-in Module Header Connection	Pin Function
J1.7	LCD SPI clock
J2.13	LCD SPI chip select
J2.15	LCD SPI MOSI
J4.31	LCD reset pin
J4.39 ⁽¹⁾	LCD backlight

⁽¹⁾ Pin is multiplexed with the RGB LED red channel pin through the jumper header J5.

2.1.9 Microphone

The CUI CMA-4544PF-W electret microphone uses an OPA344 operational amplifier to boost the output of the microphone. The human ear can hear frequencies between 0 and 20 kHz and the operating range of the microphone is 20 Hz to 20 kHz. The reference designator for the microphone is MIC1.

More information on the microphone can be found at

<http://www.cui.com/product/components/microphones/electret-condenser-microphone/cma-4544pf-w>.

Table 8. RGB LED Pinout

BoosterPack Plug-in Module Header Connection	Pin Function
J1.6	Microphone Output

2.1.10 2-Axis Joystick With Pushbutton

The ITEAD studio IM130330001 2-axis joystick with pushbutton is simply two potentiometers, one for each axis. The select button is actuated when the joystick is pressed down. The analogRead statement reads the voltage present on the joystick axis to provide the position of the joystick to the application (for example, pushing the joystick to the left reads X = 0). The reference designator for the analog joystick is JS1.

More information on the analog joystick can be found at <http://imall.itead.cc/playstation2-analog-joystick.html>.

Table 9. Joystick Pinout

BoosterPack Plug-in Module Header Connection	Pin Function
J1.2	Horizontal X-axis
J1.5	Select button
J3.26	Vertical Y-axis

2.1.11 User Pushbuttons

The user pushbuttons on the BOOSTXL-EDUMKII are connected to pullup resistors that drive the BoosterPack plug-in module pin high until the button is pressed and the pin is driven low. The reference designators for the user pushbuttons are S1 and S2.

Table 10. User Pushbuttons Pinout

BoosterPack Plug-in Module Header Connection	Pin Function
J4.32	S2 button
J4.33	S1 button

2.2 Power

The board was designed to be powered by the attached LaunchPad development kit, and requires both 3.3-V and 5-V power rails. Some 20-pin LaunchPad development kits like [MSP-EXP430FR4133](#) may not provide the necessary 5-V power, which will limit the functionality.

2.3 Design Files

2.3.1 Hardware

Schematics can be found in [Section 5](#). All design files including schematics, layout, bill of materials (BOM), Gerber files, and documentation are available in the BOOSTXL-EDUMKII Hardware Design Files on the [download page](#).

2.3.2 Software

All design files including TI-TXT object-code firmware images, software example projects, and documentation are available in the LaunchPad development kit specific software folders. To see which LaunchPad development kits feature BOOSTXL-EDUMKII examples, check the [download page](#).

2.3.3 Quick Start Guide

The Quick Start Guide is available from www.ti.com.

2.4 Hardware Change log

Table 11. Hardware Change Log

PCB Revision	Description
Rev 1.0	Initial release
Rev 1.1	Updates for CE compliance

3 Software Examples

Five software examples are included with the MSP-EXP432P401R LaunchPad development kit for the Educational BoosterPack plug-in module MKII (see [Table 12](#)). These examples can be found in the [MSP-EXP432P401R Software Examples](#), or they are more easily accessible through the [SimpleLink MSP432™ software development kit \(SDK\)](#) (see [Section 4.3](#)).

Table 12. Software Examples

Demo Name	LaunchPad Development Kit / BoosterPack Plug-in Module Required	Description	More Details
BOOSTXL-EDUMKII_Accelerometer_MSP432P401R	MSP-EXP432P401R / BOOSTXL-EDUMKII	Demonstrates how to sample data from the analog accelerometer sensor using the MSP432 ADC14	Section 3.1
BOOSTXL-EDUMKII_JoyStick_MSP432P401R	MSP-EXP432P401R / BOOSTXL-EDUMKII	Demonstrates how to sample data from the analog joystick using the MSP432 ADC14	Section 3.2
BOOSTXL-EDUMKII_LightSensor_MSP432P401R	MSP-EXP432P401R / BOOSTXL-EDUMKII	Demonstrates how to communicate with the digital ambient light sensor through I ² C using MSP432	Section 3.3
BOOSTXL-EDUMKII_Temperature_MSP432P401R	MSP-EXP432P401R / BOOSTXL-EDUMKII	Demonstrates how to communicate with the digital temperature sensor through I ² C using MSP432	Section 3.4
BOOSTXL-EDUMKII_MicrophoneFFT_MSP432P401R	MSP-EXP432P401R / BOOSTXL-EDUMKII	Demonstrates how to sample audio and perform FFT using the ARM CMSIS DSP Software Library	Section 3.5

To use any of the software examples with the LaunchPad development kit, you must have an integrated development environment (IDE) that supports the MSP432P401R device (see [Table 13](#)). For more details on how to get started quickly, and where to download the latest Code Composer Studio, IAR, and Keil IDEs, see [Section 4](#).

Table 13. IDE Minimum Requirements for MSP-EXP432P401R

Code Composer Studio™ IDE	IAR Embedded Workbench® IDE	Keil® µVision® MDK-ARM
v7.1.0	v7.80.3	v5

3.1 BOOSTXL-EDUMKII_Accelerometer_MSP432P401R

This section describes the functionality and structure of the BOOSTXL-EDUMKII_Accelerometer_MSP432P401R demo that is included in the [MSP-EXP432P401R Software Examples](#) download, or more easily accessible through the [SimpleLink MSP432 SDK](#) (see [Section 4.3](#)).

3.1.1 Source File Structure

The project is split into multiple files (see [Table 14](#)). This makes it easier to navigate and reuse parts of it for other projects.

Table 14. Source File and Folders

Name	Description
main.c	The demo's main function, interrupt service routines, global variables, and so on
mcp432_startup_ccs.c	MSP432 family interrupt vector table for CGT
Library: GrLib	MSP Graphics Library
Library: driverlib	Device driver library (MSP432DRIVERLIB)
Driver: LcdDriver	LCD specific driver files

3.1.2 Operation

This demo uses the MSP432 built-in ADC14 to sample from the 3-axis acceleration data output of the analog accelerometer on the Educational BoosterPack plug-in module MKII (see [Figure 4](#)). The measured 14-bit acceleration data are displayed on the BoosterPack plug-in module's colored 128x128 dot-matrix LCD. Using [MSP Graphics Library](#), the MSP432 MCU sends data to the LCD controller through SPI communication to draw texts.

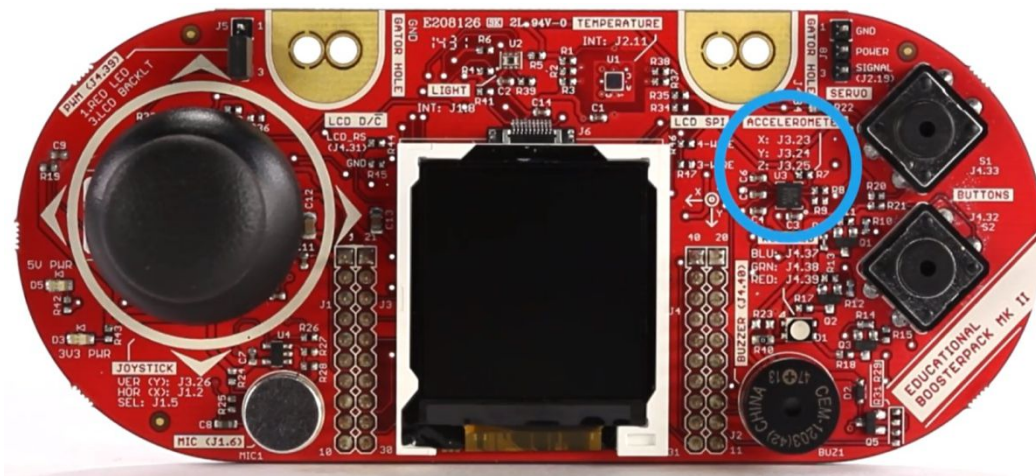

3.2 BOOSTXL-EDUMKII_JoyStick_MSP432P401R

This section describes the functionality and structure of the BOOSTXL-EDUMKII_JoyStick_MSP432P401R demo that is included in the [MSP-EXP432P401R Software Examples](#) download, or more easily accessible through the [SimpleLink MSP432 SDK](#) (see [Section 4.3](#)).

3.2.1 Source File Structure

The project is divided into multiple files (see [Table 15](#)). This makes it easier to navigate and reuse parts of it for other projects.

Table 15. Source File and Folders

Name	Description
main.c	The demo's main function, interrupt service routines, global variables, and so on
mcp432_startup_ccs.c	MSP432 family interrupt vector table for CGT
Library: GrLib	MSP Graphics Library
Library: driverlib	Device driver library (MSP432DRIVERLIB)
Driver: LcdDriver	LCD specific driver files

3.2.2 Operation

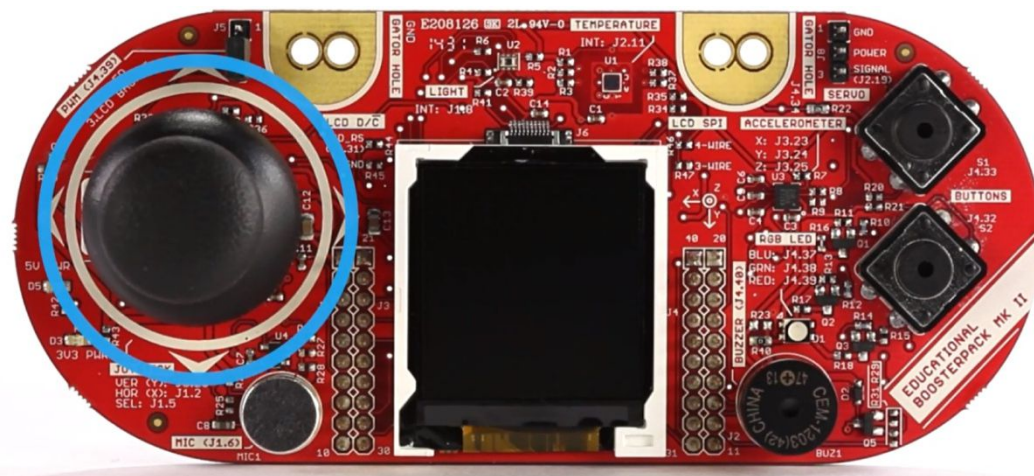

Figure 5. 2-Axis Analog Joystick With Digital Input

This demo uses the MSP432 built-in ADC14 to sample from the 2-axis of the analog joystick on the Educational BoosterPack plug-in module MKII. The measured 14-bit X and Y axis data are displayed on the BoosterPack plug-in module's colored 128x128 dot-matrix LCD. Using [MSP Graphics Library](#), the MSP432 MCU sends data to the LCD controller through SPI communication to draw texts.

3.3 BOOSTXL-EDUMKII_LightSensor_MSP432P401R

This section describes the functionality and structure of the BOOSTXL-EDUMKII_LightSensor_MSP432P401R demo that is included in the [MSP-EXP432P401R Software Examples](#) download, or more easily accessible through the [SimpleLink MSP432 SDK](#) (see [Section 4.3](#)).

3.3.1 Source File Structure

The project is split into multiple files (see [Table 16](#)). This makes it easier to navigate and reuse parts of it for other projects.

Table 16. Source File and Folders

Name	Description
main.c	The demo's main function, interrupt service routines, global variables, and so on
mcp432_startup_ccs.c	MSP432 family interrupt vector table for CGT
Library: GrLib	MSP Graphics Library
Library: driverlib	Device driver library (MSP432DRIVERLIB)
Driver: LcdDriver	LCD specific driver files
Driver: HAL_I2C.c	Generic I2C driver file
Driver: HAL_OPT3001.c	OPT3001 sensor specific driver built on top of the HAL_I2C driver

3.3.2 Operation

This demo uses the MSP432 built-in eUSCI module in I²C mode to initialize and gather data from the digital ambient light sensor, OPT3001, on the Educational BoosterPack plug-in module MKII (see [Figure 6](#)). The measured illuminance value (Lux) is displayed on the colored 128x128 dot-matrix LCD of the BoosterPack plug-in module. Using [MSP Graphics Library](#), the MSP432 MCU sends data to the LCD controller through SPI communication to draw texts.

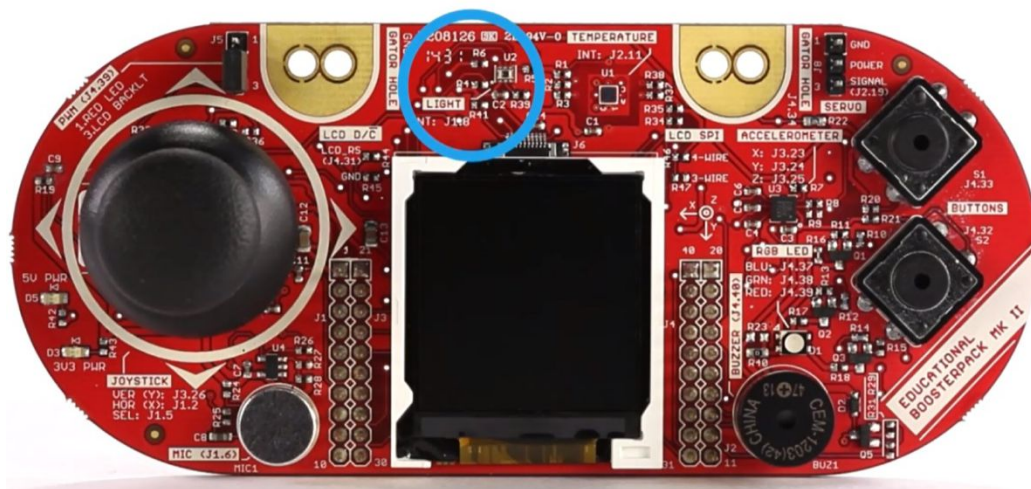

Figure 6. OPT3001 Ambient Light Sensor

The demo also controls the brightness of the LCD backlight LED by generating a Timer PWM.

NOTE: Make sure that the **J5 jumper** on the BOOSTXL-EDUMKII is connected to **3.LCD BACKLT**

The demo makes use of the illuminance value by brightening the LCD backlight when high illuminance value is detected, or by dimming the LCD backlight when low illuminance value is detected.

3.4 BOOSTXL-EDUMKII_Temperature_MSP432P401R

This section describes the functionality and structure of the BOOSTXL-EDUMKII_Temperature_MSP432P401R demo that is included in the [MSP-EXP432P401R Software Examples](#) download, or more easily accessible through the [SimpleLink MSP432 SDK](#) (see [Section 4.3](#)).

3.4.1 Source File Structure

The project is split into multiple files (see [Table 17](#)). This makes it easier to navigate and reuse parts of it for other projects.

Table 17. Source File and Folders

Name	Description
main.c	The demo's main function, interrupt service routines, global variables, and so on
mcp432_startup_ccs.c	MSP432 family interrupt vector table for CGT
Library: GrLib	MSP Graphics Library
Library: driverlib	Device driver library (MSP432DRIVERLIB)
Driver: LcdDriver	LCD specific driver files
Driver: HAL_I2C.c	Generic I2C driver file
Driver: HAL_TMP006.c	TMP006 sensor specific driver built on top of the HAL_I2C driver

3.4.2 Operation

This demo uses the MSP432 built-in eUSCI module in I²C mode to initialize and gather data from the digital infrared temperature sensor, TMP006, on the Educational BoosterPack plug-in module MKII (see [Figure 7](#)). The measured temperature (°F) is displayed on the colored 128x128 dot-matrix LCD of the BoosterPack plug-in module.

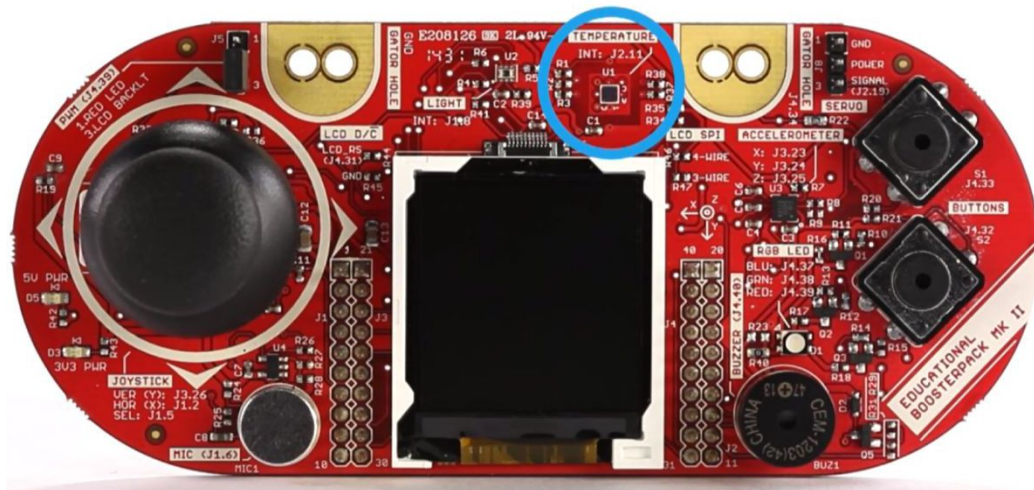

Figure 7. TMP006 Infrared Contactless Temperature Sensor

3.5 BOOSTXL-EDUMKII_MicrophoneFFT_MSP432P401R

This section describes the functionality and structure of the BOOSTXL-EDUMKII_MicrophoneFFT_MSP432P401R demo that is included in the [MSP-EXP432P401R Software Examples](#) download, or more easily accessible through the [SimpleLink MSP432 SDK](#) (see [Section 4.3](#)).

3.5.1 Source File Structure

The project is split into multiple files (see [Table 18](#)). This makes it easier to navigate and reuse parts of it for other projects.

Table 18. Source File and Folders

Name	Description
main.c	The demo's main function, interrupt service routines, global variables, and so on
mSP432_startup_ccs.c	MSP432 Family Interrupt Vector Table for CGT
Library: GrLib	MSP Graphics Library
Library: driverlib	Device driver library (MSP432DRIVERLIB)
Driver: LcdDriver	LCD specific driver files
Driver: HAL_I2C.c	Generic I2C driver file
Driver: HAL_OPT3001.c	OPT3001 sensor specific driver built on top of the HAL_I2C driver

3.5.2 Operation

This demo visualizes 512-point real FFT results calculated from audio samples gathered in real-time from the onboard microphone of the Educational BoosterPack plug-in module MKII (see [Figure 8](#)). The demo uses the real FFT function contained in the CMSIS DSP Software Library.

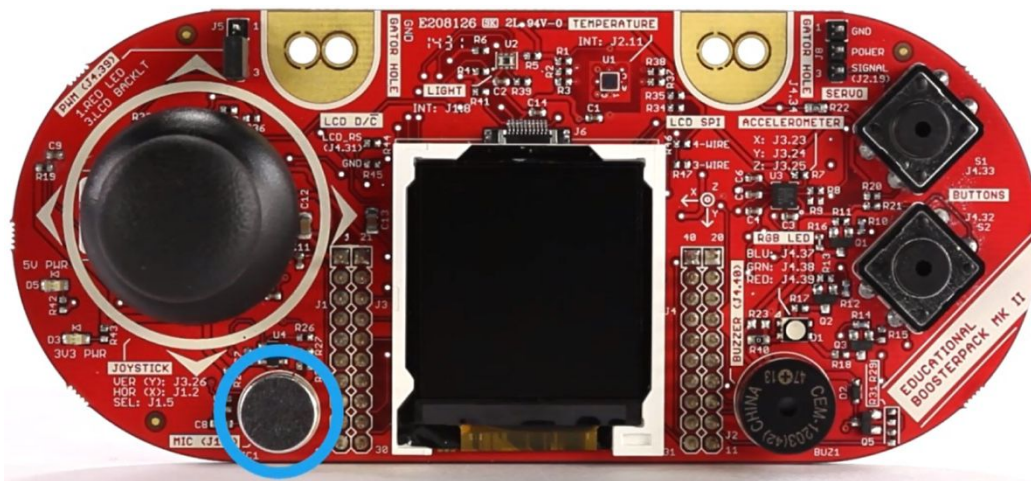

Figure 8. Microphone

The program begins by using the MSP432 built-in ADC14 module to sample audio signal at 8 KHz from the microphone on the Educational BoosterPack plug-in module MKII. To achieve seamless data processing, the MSP432 built-in DMA module is set up in Ping-Pong mode to alternate between two data buffers. This allows the ADC14 module to continue gathering audio data into one buffer, while the MSP432 runs the FFT algorithm on the other buffer.

When the DMA module completes data transfers from ADC14 results to one of the 512 length data buffers, an interrupt is triggered to wake the MSP432 from LPM0 sleep mode to initiate the 512-point real FFT calculation. The resulting frequency bin data is displayed in a bar graph on the BoosterPack plug-in module's colored 128x128 dot-matrix LCD using [MSP Graphics Library](#).

Try generating a pure tone ranging from 1 Hz to 4000 Hz and see if the demo shows the correct frequency.

3.5.3 CMSIS DSP Software Library in MSP432

This demo uses a pre-built CMSIS DSP Software Library file. However, a separate project, **dsplib-mbsp432**, is included in the [MSP-EXP432P401R Software Examples](#) download, showing how to compile the ARM [CMSIS DSP Software Library](#) with a MSP432 device in Code Composer Studio IDE.

It opens up access to the suite of signal processing functions in the CMSIS DSP Software Library for MSP432 MCUs inside the Code Composer Studio development environment.

4 Additional Resources

4.1 TI LaunchPad Development Kit Portal

More information about LaunchPad development kits, supported BoosterPack plug-in modules, and available resources can be found at:

- [TI's LaunchPad portal](#): information about all LaunchPad development kits from TI, for all MCUs

4.2 Download Code Composer Studio IDE, IAR, or Energia

Although the files can be viewed with any text editor, more can be done with the projects if they are opened with a [development environment](#) like Code Composer Studio IDE, IAR, or Energia.

4.3 SimpleLink MSP432 SDK and TI Resource Explorer

The MSP432 device is part of the SimpleLink microcontroller (MCU) platform, which consists of Wi-Fi®, Bluetooth® low energy, Sub-1 GHz, and host MCUs. All share a common, easy-to-use development environment with a single core software development kit (SDK) and rich tool set. A one-time integration of the SimpleLink platform lets you add any combination of devices from the portfolio into your design. The ultimate goal of the SimpleLink platform is to achieve 100 percent code reuse when your design requirements change. For more information, visit www.ti.com/simplelink.

The SimpleLink MSP432 SDK is included in the TI Resource Explorer for easily browsing tools, documents, examples, and more (see [Figure 9](#)).

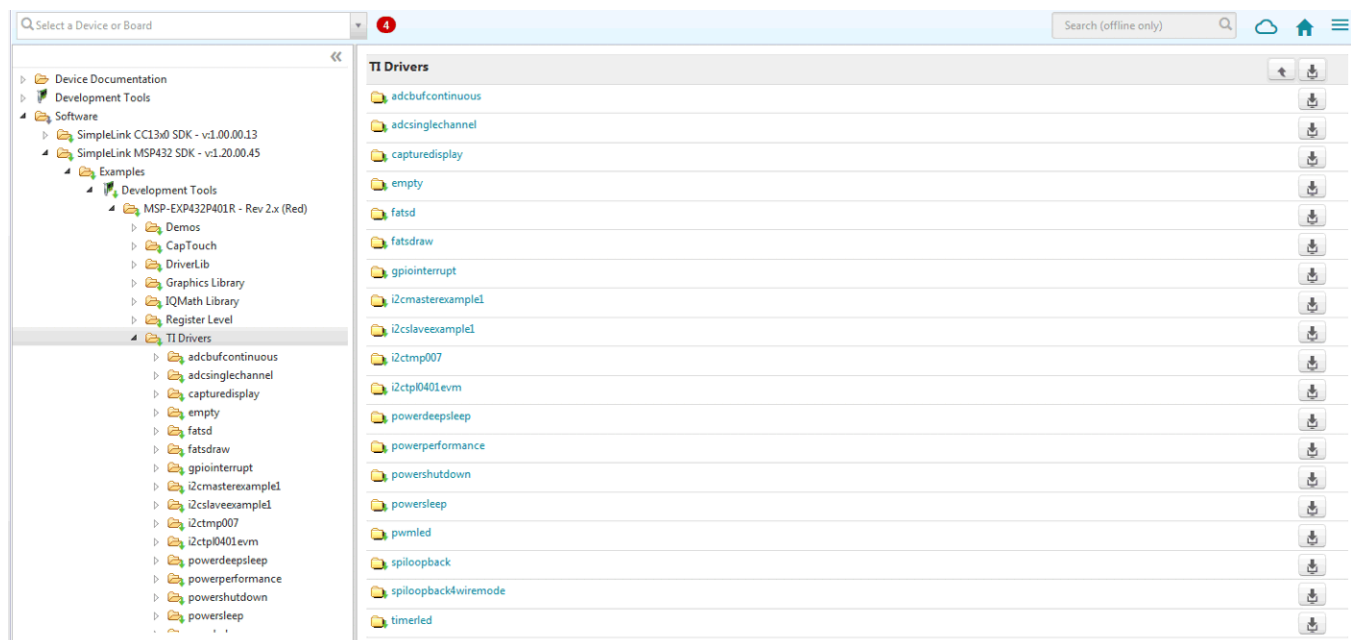

Figure 9. TI Drivers Software Examples in TI Resource Explorer

Inside TI Resource Explorer, these examples and many more can be found and easily imported into Code Composer Studio IDE with one click.

4.4 The Community

4.4.1 TI E2E™ Community

Search the TI E2E™ community forums at <http://e2e.ti.com>. If you cannot find your answer, post your question to the community.

4.4.2 Community at Large

Many online communities focus on the LaunchPad development kit and BoosterPack plug-in module ecosystem – for example, <http://www.43oh.com>. You can find additional tools, resources, and support from these communities.

5 Schematics

[Figure 10](#) and [Figure 11](#) show the schematics. All hardware design files can be found on the [download page](#).

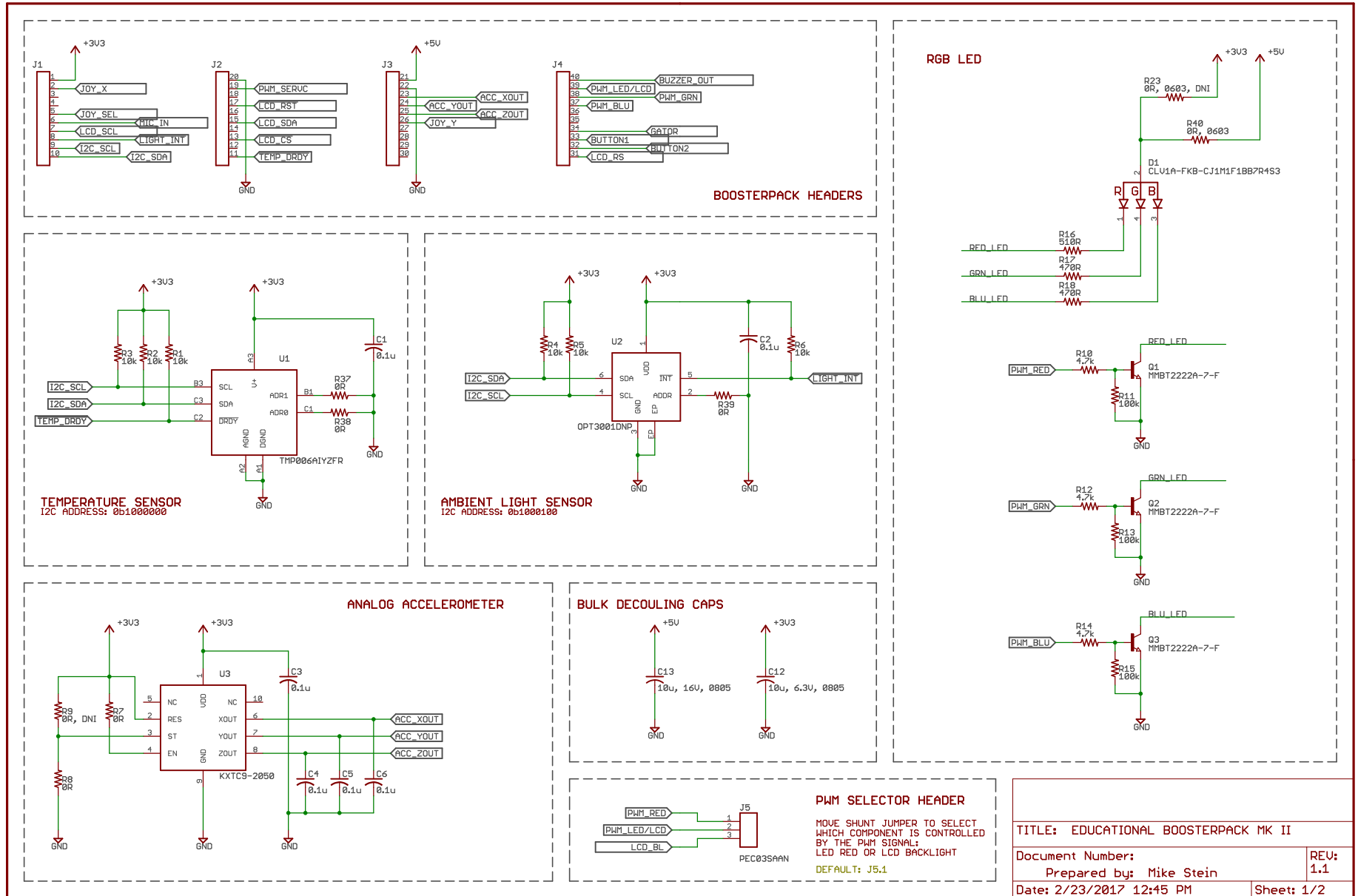

Figure 10. Schematics (1 of 2)

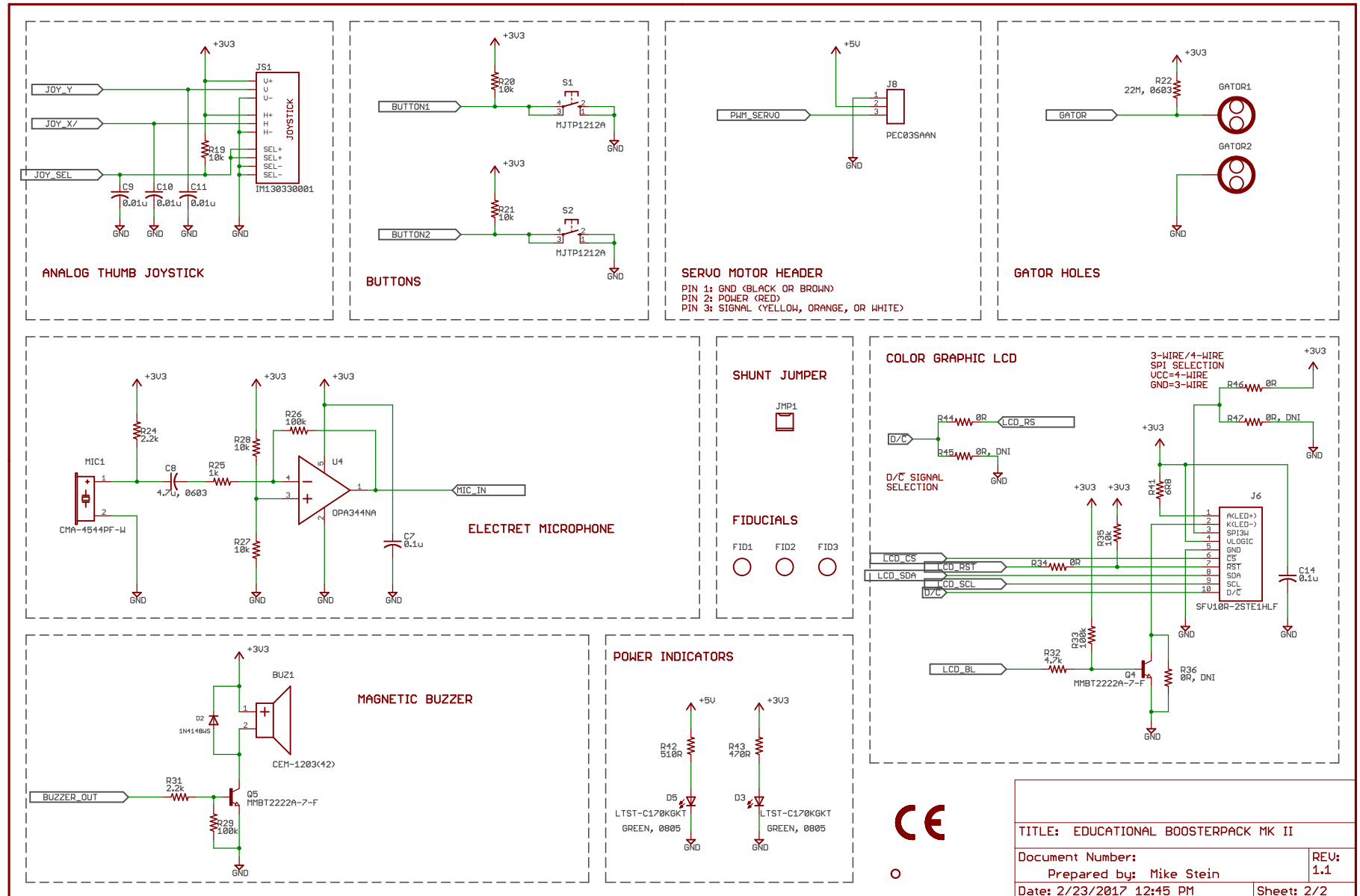

Figure 11. Schematics (2 of 2)

Revision History

Changes from August 22, 2015 to March 6, 2017
Page

<ul style="list-style-type: none"> • Added Rev 1.1 to Table 11, <i>Hardware Change Log</i>..... • Updated the required versions in Table 13, <i>IDE Minimum Requirements for MSP-EXP432P401R</i>..... • Throughout document, changed "MSPWare" to "SimpleLink MSP432 SDK" • Updated all content in Section 4.3, <i>SimpleLink MSP432 SDK and TI Resource Explorer</i>..... • Updated all figures in Section 5, <i>Schematics</i> 	<p>9</p> <p>9</p> <p>10</p> <p>15</p> <p>17</p>
---	---

STANDARD TERMS FOR EVALUATION MODULES

1. *Delivery:* TI delivers TI evaluation boards, kits, or modules, including any accompanying demonstration software, components, and/or documentation which may be provided together or separately (collectively, an "EVM" or "EVMs") to the User ("User") in accordance with the terms set forth herein. User's acceptance of the EVM is expressly subject to the following terms.
 - 1.1 EVMs are intended solely for product or software developers for use in a research and development setting to facilitate feasibility evaluation, experimentation, or scientific analysis of TI semiconductors products. EVMs have no direct function and are not finished products. EVMs shall not be directly or indirectly assembled as a part or subassembly in any finished product. For clarification, any software or software tools provided with the EVM ("Software") shall not be subject to the terms and conditions set forth herein but rather shall be subject to the applicable terms that accompany such Software
 - 1.2 EVMs are not intended for consumer or household use. EVMs may not be sold, sublicensed, leased, rented, loaned, assigned, or otherwise distributed for commercial purposes by Users, in whole or in part, or used in any finished product or production system.
2. *Limited Warranty and Related Remedies/Disclaimers:*
 - 2.1 These terms do not apply to Software. The warranty, if any, for Software is covered in the applicable Software License Agreement.
 - 2.2 TI warrants that the TI EVM will conform to TI's published specifications for ninety (90) days after the date TI delivers such EVM to User. Notwithstanding the foregoing, TI shall not be liable for a nonconforming EVM if (a) the nonconformity was caused by neglect, misuse or mistreatment by an entity other than TI, including improper installation or testing, or for any EVMs that have been altered or modified in any way by an entity other than TI, (b) the nonconformity resulted from User's design, specifications or instructions for such EVMs or improper system design, or (c) User has not paid on time. Testing and other quality control techniques are used to the extent TI deems necessary. TI does not test all parameters of each EVM. User's claims against TI under this Section 2 are void if User fails to notify TI of any apparent defects in the EVMs within ten (10) business days after delivery, or of any hidden defects with ten (10) business days after the defect has been detected.
 - 2.3 TI's sole liability shall be at its option to repair or replace EVMs that fail to conform to the warranty set forth above, or credit User's account for such EVM. TI's liability under this warranty shall be limited to EVMs that are returned during the warranty period to the address designated by TI and that are determined by TI not to conform to such warranty. If TI elects to repair or replace such EVM, TI shall have a reasonable time to repair such EVM or provide replacements. Repaired EVMs shall be warranted for the remainder of the original warranty period. Replaced EVMs shall be warranted for a new full ninety (90) day warranty period.

WARNING

Evaluation Kits are intended solely for use by technically qualified, professional electronics experts who are familiar with the dangers and application risks associated with handling electrical mechanical components, systems, and subsystems.

User shall operate the Evaluation Kit within TI's recommended guidelines and any applicable legal or environmental requirements as well as reasonable and customary safeguards. Failure to set up and/or operate the Evaluation Kit within TI's recommended guidelines may result in personal injury or death or property damage. Proper set up entails following TI's instructions for electrical ratings of interface circuits such as input, output and electrical loads.

NOTE:

EXPOSURE TO ELECTROSTATIC DISCHARGE (ESD) MAY CAUSE DEGRADATION OR FAILURE OF THE EVALUATION KIT; TI RECOMMENDS STORAGE OF THE EVALUATION KIT IN A PROTECTIVE ESD BAG.

3 Regulatory Notices:

3.1 United States

3.1.1 Notice applicable to EVMs not FCC-Approved:

FCC NOTICE: This kit is designed to allow product developers to evaluate electronic components, circuitry, or software associated with the kit to determine whether to incorporate such items in a finished product and software developers to write software applications for use with the end product. This kit is not a finished product and when assembled may not be resold or otherwise marketed unless all required FCC equipment authorizations are first obtained. Operation is subject to the condition that this product not cause harmful interference to licensed radio stations and that this product accept harmful interference. Unless the assembled kit is designed to operate under part 15, part 18 or part 95 of this chapter, the operator of the kit must operate under the authority of an FCC license holder or must secure an experimental authorization under part 5 of this chapter.

3.1.2 For EVMs annotated as FCC – FEDERAL COMMUNICATIONS COMMISSION Part 15 Compliant:

CAUTION

This device complies with part 15 of the FCC Rules. Operation is subject to the following two conditions: (1) This device may not cause harmful interference, and (2) this device must accept any interference received, including interference that may cause undesired operation.

Changes or modifications not expressly approved by the party responsible for compliance could void the user's authority to operate the equipment.

FCC Interference Statement for Class A EVM devices

NOTE: This equipment has been tested and found to comply with the limits for a Class A digital device, pursuant to part 15 of the FCC Rules. These limits are designed to provide reasonable protection against harmful interference when the equipment is operated in a commercial environment. This equipment generates, uses, and can radiate radio frequency energy and, if not installed and used in accordance with the instruction manual, may cause harmful interference to radio communications. Operation of this equipment in a residential area is likely to cause harmful interference in which case the user will be required to correct the interference at his own expense.

FCC Interference Statement for Class B EVM devices

NOTE: This equipment has been tested and found to comply with the limits for a Class B digital device, pursuant to part 15 of the FCC Rules. These limits are designed to provide reasonable protection against harmful interference in a residential installation. This equipment generates, uses and can radiate radio frequency energy and, if not installed and used in accordance with the instructions, may cause harmful interference to radio communications. However, there is no guarantee that interference will not occur in a particular installation. If this equipment does cause harmful interference to radio or television reception, which can be determined by turning the equipment off and on, the user is encouraged to try to correct the interference by one or more of the following measures:

- Reorient or relocate the receiving antenna.
- Increase the separation between the equipment and receiver.
- Connect the equipment into an outlet on a circuit different from that to which the receiver is connected.
- Consult the dealer or an experienced radio/TV technician for help.

3.2 Canada

3.2.1 For EVMs issued with an Industry Canada Certificate of Conformance to RSS-210 or RSS-247

Concerning EVMs Including Radio Transmitters:

This device complies with Industry Canada license-exempt RSSs. Operation is subject to the following two conditions:

(1) this device may not cause interference, and (2) this device must accept any interference, including interference that may cause undesired operation of the device.

Concernant les EVMs avec appareils radio:

Le présent appareil est conforme aux CNR d'Industrie Canada applicables aux appareils radio exempts de licence. L'exploitation est autorisée aux deux conditions suivantes: (1) l'appareil ne doit pas produire de brouillage, et (2) l'utilisateur de l'appareil doit accepter tout brouillage radioélectrique subi, même si le brouillage est susceptible d'en compromettre le fonctionnement.

Concerning EVMs Including Detachable Antennas:

Under Industry Canada regulations, this radio transmitter may only operate using an antenna of a type and maximum (or lesser) gain approved for the transmitter by Industry Canada. To reduce potential radio interference to other users, the antenna type and its gain should be so chosen that the equivalent isotropically radiated power (e.i.r.p.) is not more than that necessary for successful communication. This radio transmitter has been approved by Industry Canada to operate with the antenna types listed in the user guide with the maximum permissible gain and required antenna impedance for each antenna type indicated. Antenna types not included in this list, having a gain greater than the maximum gain indicated for that type, are strictly prohibited for use with this device.

Concernant les EVMs avec antennes détachables

Conformément à la réglementation d'Industrie Canada, le présent émetteur radio peut fonctionner avec une antenne d'un type et d'un gain maximal (ou inférieur) approuvé pour l'émetteur par Industrie Canada. Dans le but de réduire les risques de brouillage radioélectrique à l'intention des autres utilisateurs, il faut choisir le type d'antenne et son gain de sorte que la puissance isotrope rayonnée équivalente (p.i.r.e.) ne dépasse pas l'intensité nécessaire à l'établissement d'une communication satisfaisante. Le présent émetteur radio a été approuvé par Industrie Canada pour fonctionner avec les types d'antenne énumérés dans le manuel d'usage et ayant un gain admissible maximal et l'impédance requise pour chaque type d'antenne. Les types d'antenne non inclus dans cette liste, ou dont le gain est supérieur au gain maximal indiqué, sont strictement interdits pour l'exploitation de l'émetteur.

3.3 Japan

3.3.1 *Notice for EVMs delivered in Japan:* Please see http://www.tij.co.jp/lstds/ti_ja/general/eStore/notice_01.page 日本国内に輸入される評価用キット、ボードについては、次のところをご覧ください。
http://www.tij.co.jp/lstds/ti_ja/general/eStore/notice_01.page

3.3.2 *Notice for Users of EVMs Considered "Radio Frequency Products" in Japan:* EVMs entering Japan may not be certified by TI as conforming to Technical Regulations of Radio Law of Japan.

If User uses EVMs in Japan, not certified to Technical Regulations of Radio Law of Japan, User is required to follow the instructions set forth by Radio Law of Japan, which includes, but is not limited to, the instructions below with respect to EVMs (which for the avoidance of doubt are stated strictly for convenience and should be verified by User):

1. Use EVMs in a shielded room or any other test facility as defined in the notification #173 issued by Ministry of Internal Affairs and Communications on March 28, 2006, based on Sub-section 1.1 of Article 6 of the Ministry's Rule for Enforcement of Radio Law of Japan,
2. Use EVMs only after User obtains the license of Test Radio Station as provided in Radio Law of Japan with respect to EVMs, or
3. Use of EVMs only after User obtains the Technical Regulations Conformity Certification as provided in Radio Law of Japan with respect to EVMs. Also, do not transfer EVMs, unless User gives the same notice above to the transferee. Please note that if User does not follow the instructions above, User will be subject to penalties of Radio Law of Japan.

【無線電波を送信する製品の開発キットをお使いになる際の注意事項】 開発キットの中には技術基準適合証明を受けていないものがあります。技術適合証明を受けていないものご使用に際しては、電波法遵守のため、以下のいずれかの措置を取っていただく必要がありますのでご注意ください。

1. 電波法施行規則第6条第1項第1号に基づく平成18年3月28日総務省告示第173号で定められた電波暗室等の試験設備でご使用いただく。
2. 実験局の免許を取得後ご使用いただく。
3. 技術基準適合証明を取得後ご使用いただく。

なお、本製品は、上記の「ご使用にあたっての注意」を譲渡先、移転先に通知しない限り、譲渡、移転できないものとします。

上記を遵守頂けない場合は、電波法の罰則が適用される可能性があることをご留意ください。日本テキサス・インスツルメンツ株式会社
東京都新宿区西新宿 6 丁目 2 4 番 1 号
西新宿三井ビル

3.3.3 *Notice for EVMs for Power Line Communication:* Please see http://www.tij.co.jp/lstds/ti_ja/general/eStore/notice_02.page
電力線搬送波通信についての開発キットをお使いになる際の注意事項については、次のところをご覧ください。http://www.tij.co.jp/lstds/ti_ja/general/eStore/notice_02.page

3.4 European Union

3.4.1 *For EVMs subject to EU Directive 2014/30/EU (Electromagnetic Compatibility Directive):*

This is a class A product intended for use in environments other than domestic environments that are connected to a low-voltage power-supply network that supplies buildings used for domestic purposes. In a domestic environment this product may cause radio interference in which case the user may be required to take adequate measures.

-
- 4 *EVM Use Restrictions and Warnings:*
 - 4.1 EVMS ARE NOT FOR USE IN FUNCTIONAL SAFETY AND/OR SAFETY CRITICAL EVALUATIONS, INCLUDING BUT NOT LIMITED TO EVALUATIONS OF LIFE SUPPORT APPLICATIONS.
 - 4.2 User must read and apply the user guide and other available documentation provided by TI regarding the EVM prior to handling or using the EVM, including without limitation any warning or restriction notices. The notices contain important safety information related to, for example, temperatures and voltages.
 - 4.3 *Safety-Related Warnings and Restrictions:*
 - 4.3.1 User shall operate the EVM within TI's recommended specifications and environmental considerations stated in the user guide, other available documentation provided by TI, and any other applicable requirements and employ reasonable and customary safeguards. Exceeding the specified performance ratings and specifications (including but not limited to input and output voltage, current, power, and environmental ranges) for the EVM may cause personal injury or death, or property damage. If there are questions concerning performance ratings and specifications, User should contact a TI field representative prior to connecting interface electronics including input power and intended loads. Any loads applied outside of the specified output range may also result in unintended and/or inaccurate operation and/or possible permanent damage to the EVM and/or interface electronics. Please consult the EVM user guide prior to connecting any load to the EVM output. If there is uncertainty as to the load specification, please contact a TI field representative. During normal operation, even with the inputs and outputs kept within the specified allowable ranges, some circuit components may have elevated case temperatures. These components include but are not limited to linear regulators, switching transistors, pass transistors, current sense resistors, and heat sinks, which can be identified using the information in the associated documentation. When working with the EVM, please be aware that the EVM may become very warm.
 - 4.3.2 EVMs are intended solely for use by technically qualified, professional electronics experts who are familiar with the dangers and application risks associated with handling electrical mechanical components, systems, and subsystems. User assumes all responsibility and liability for proper and safe handling and use of the EVM by User or its employees, affiliates, contractors or designees. User assumes all responsibility and liability to ensure that any interfaces (electronic and/or mechanical) between the EVM and any human body are designed with suitable isolation and means to safely limit accessible leakage currents to minimize the risk of electrical shock hazard. User assumes all responsibility and liability for any improper or unsafe handling or use of the EVM by User or its employees, affiliates, contractors or designees.
 - 4.4 User assumes all responsibility and liability to determine whether the EVM is subject to any applicable international, federal, state, or local laws and regulations related to User's handling and use of the EVM and, if applicable, User assumes all responsibility and liability for compliance in all respects with such laws and regulations. User assumes all responsibility and liability for proper disposal and recycling of the EVM consistent with all applicable international, federal, state, and local requirements.
 5. *Accuracy of Information:* To the extent TI provides information on the availability and function of EVMs, TI attempts to be as accurate as possible. However, TI does not warrant the accuracy of EVM descriptions, EVM availability or other information on its websites as accurate, complete, reliable, current, or error-free.
 6. *Disclaimers:*
 - 6.1 EXCEPT AS SET FORTH ABOVE, EVMS AND ANY MATERIALS PROVIDED WITH THE EVM (INCLUDING, BUT NOT LIMITED TO, REFERENCE DESIGNS AND THE DESIGN OF THE EVM ITSELF) ARE PROVIDED "AS IS" AND "WITH ALL FAULTS." TI DISCLAIMS ALL OTHER WARRANTIES, EXPRESS OR IMPLIED, REGARDING SUCH ITEMS, INCLUDING BUT NOT LIMITED TO ANY EPIDEMIC FAILURE WARRANTY OR IMPLIED WARRANTIES OF MERCHANTABILITY OR FITNESS FOR A PARTICULAR PURPOSE OR NON-INFRINGEMENT OF ANY THIRD PARTY PATENTS, COPYRIGHTS, TRADE SECRETS OR OTHER INTELLECTUAL PROPERTY RIGHTS.
 - 6.2 EXCEPT FOR THE LIMITED RIGHT TO USE THE EVM SET FORTH HEREIN, NOTHING IN THESE TERMS SHALL BE CONSTRUED AS GRANTING OR CONFERRING ANY RIGHTS BY LICENSE, PATENT, OR ANY OTHER INDUSTRIAL OR INTELLECTUAL PROPERTY RIGHT OF TI, ITS SUPPLIERS/LICENSORS OR ANY OTHER THIRD PARTY, TO USE THE EVM IN ANY FINISHED END-USER OR READY-TO-USE FINAL PRODUCT, OR FOR ANY INVENTION, DISCOVERY OR IMPROVEMENT, REGARDLESS OF WHEN MADE, CONCEIVED OR ACQUIRED.
 7. *USER'S INDEMNITY OBLIGATIONS AND REPRESENTATIONS.* USER WILL DEFEND, INDEMNIFY AND HOLD TI, ITS LICENSORS AND THEIR REPRESENTATIVES HARMLESS FROM AND AGAINST ANY AND ALL CLAIMS, DAMAGES, LOSSES, EXPENSES, COSTS AND LIABILITIES (COLLECTIVELY, "CLAIMS") ARISING OUT OF OR IN CONNECTION WITH ANY HANDLING OR USE OF THE EVM THAT IS NOT IN ACCORDANCE WITH THESE TERMS. THIS OBLIGATION SHALL APPLY WHETHER CLAIMS ARISE UNDER STATUTE, REGULATION, OR THE LAW OF TORT, CONTRACT OR ANY OTHER LEGAL THEORY, AND EVEN IF THE EVM FAILS TO PERFORM AS DESCRIBED OR EXPECTED.
-

8. *Limitations on Damages and Liability:*

8.1 *General Limitations.* IN NO EVENT SHALL TI BE LIABLE FOR ANY SPECIAL, COLLATERAL, INDIRECT, PUNITIVE, INCIDENTAL, CONSEQUENTIAL, OR EXEMPLARY DAMAGES IN CONNECTION WITH OR ARISING OUT OF THESE TERMS OR THE USE OF THE EVMS , REGARDLESS OF WHETHER TI HAS BEEN ADVISED OF THE POSSIBILITY OF SUCH DAMAGES. EXCLUDED DAMAGES INCLUDE, BUT ARE NOT LIMITED TO, COST OF REMOVAL OR REINSTALLATION, ANCILLARY COSTS TO THE PROCUREMENT OF SUBSTITUTE GOODS OR SERVICES, RETESTING, OUTSIDE COMPUTER TIME, LABOR COSTS, LOSS OF GOODWILL, LOSS OF PROFITS, LOSS OF SAVINGS, LOSS OF USE, LOSS OF DATA, OR BUSINESS INTERRUPTION. NO CLAIM, SUIT OR ACTION SHALL BE BROUGHT AGAINST TI MORE THAN TWELVE (12) MONTHS AFTER THE EVENT THAT GAVE RISE TO THE CAUSE OF ACTION HAS OCCURRED.

8.2 *Specific Limitations.* IN NO EVENT SHALL TI'S AGGREGATE LIABILITY FROM ANY USE OF AN EVM PROVIDED HEREUNDER, INCLUDING FROM ANY WARRANTY, INDEMNITY OR OTHER OBLIGATION ARISING OUT OF OR IN CONNECTION WITH THESE TERMS, , EXCEED THE TOTAL AMOUNT PAID TO TI BY USER FOR THE PARTICULAR EVM(S) AT ISSUE DURING THE PRIOR TWELVE (12) MONTHS WITH RESPECT TO WHICH LOSSES OR DAMAGES ARE CLAIMED. THE EXISTENCE OF MORE THAN ONE CLAIM SHALL NOT ENLARGE OR EXTEND THIS LIMIT.

9. *Return Policy.* Except as otherwise provided, TI does not offer any refunds, returns, or exchanges. Furthermore, no return of EVM(s) will be accepted if the package has been opened and no return of the EVM(s) will be accepted if they are damaged or otherwise not in a resalable condition. If User feels it has been incorrectly charged for the EVM(s) it ordered or that delivery violates the applicable order, User should contact TI. All refunds will be made in full within thirty (30) working days from the return of the components(s), excluding any postage or packaging costs.

10. *Governing Law:* These terms and conditions shall be governed by and interpreted in accordance with the laws of the State of Texas, without reference to conflict-of-laws principles. User agrees that non-exclusive jurisdiction for any dispute arising out of or relating to these terms and conditions lies within courts located in the State of Texas and consents to venue in Dallas County, Texas. Notwithstanding the foregoing, any judgment may be enforced in any United States or foreign court, and TI may seek injunctive relief in any United States or foreign court.

Mailing Address: Texas Instruments, Post Office Box 655303, Dallas, Texas 75265
Copyright © 2019, Texas Instruments Incorporated

IMPORTANT NOTICE AND DISCLAIMER

TI PROVIDES TECHNICAL AND RELIABILITY DATA (INCLUDING DATASHEETS), DESIGN RESOURCES (INCLUDING REFERENCE DESIGNS), APPLICATION OR OTHER DESIGN ADVICE, WEB TOOLS, SAFETY INFORMATION, AND OTHER RESOURCES "AS IS" AND WITH ALL FAULTS, AND DISCLAIMS ALL WARRANTIES, EXPRESS AND IMPLIED, INCLUDING WITHOUT LIMITATION ANY IMPLIED WARRANTIES OF MERCHANTABILITY, FITNESS FOR A PARTICULAR PURPOSE OR NON-INFRINGEMENT OF THIRD PARTY INTELLECTUAL PROPERTY RIGHTS.

These resources are intended for skilled developers designing with TI products. You are solely responsible for (1) selecting the appropriate TI products for your application, (2) designing, validating and testing your application, and (3) ensuring your application meets applicable standards, and any other safety, security, or other requirements. These resources are subject to change without notice. TI grants you permission to use these resources only for development of an application that uses the TI products described in the resource. Other reproduction and display of these resources is prohibited. No license is granted to any other TI intellectual property right or to any third party intellectual property right. TI disclaims responsibility for, and you will fully indemnify TI and its representatives against, any claims, damages, costs, losses, and liabilities arising out of your use of these resources.

TI's products are provided subject to TI's Terms of Sale (www.ti.com/legal/termsofsale.html) or other applicable terms available either on ti.com or provided in conjunction with such TI products. TI's provision of these resources does not expand or otherwise alter TI's applicable warranties or warranty disclaimers for TI products.

Mailing Address: Texas Instruments, Post Office Box 655303, Dallas, Texas 75265
Copyright © 2019, Texas Instruments Incorporated