

M68HC11EVB/D
REV 2

November 1996

M68HC11EVB
EVALUATION BOARD
USER'S MANUAL

Copyright 1986, 1996 by Motorola Inc.

Motorola reserves the right to make changes without further notice to any products herein to improve reliability, function or design. Motorola does not assume any liability arising out of the application or use of any product or circuit described herein; neither does it convey any license under its patent rights nor the rights of others. Motorola products are not designed, intended, or authorized for use as components in systems intended for surgical implant into the body, or other applications intended to support or sustain life, or for any other application in which the failure of the Motorola product could create a situation where personal injury or death may occur. Should Buyer purchase or use Motorola products for any such unintended or unauthorized application, Buyer shall indemnify and hold Motorola and its officers, employees, subsidiaries, affiliates, and distributors harmless against all claims, costs, damages, and expenses, and reasonable attorney fees arising out of, directly or indirectly, any claim of personal injury or death associated with such unintended or unauthorized use, even if such claim alleges that Motorola was negligent regarding the design or manufacture of the part.

**Information contained in this document applies to
REVision (C) M68HC11EVB Evaluation Boards,
serial numbers 6000 through 99,999.**

The computer program stored in the Read Only Memory of the device contains material copyrighted by Motorola Inc., first published 1985, and may be used only under a license such as the License For Computer Programs (Article 14) contained in Motorola's Terms and Conditions of Sale, Rev. 1/79.

EXORciser is a trademark of Motorola Inc.

IBM-PC is a registered trademark of International Business Machines Corp.

Apple, MacTerminal, MacWrite are trademarks of Apple Computer, Inc.

Macintosh is a trademark licensed to Apple Computer, Inc.

Macintosh is a trademark of Macintosh Laboratory, Inc.

Red Ryder is a trademark of Freesoft Company

Motorola and the Motorola logo are registered trademarks of Motorola Inc.

Motorola Inc. is an Equal Opportunity/Affirmative Action Employer.

CAUTION

Caution should be observed when programming or erasing MCU EEPROM locations. The EVB MCU configuration (CONFIG) register ROMON bit is cleared to disable MCU internal ROM, thereby allowing external EPROM containing the BUFFALO program to control EVB operations.

CONTENTS

CHAPTER 1 GENERAL INFORMATION

1.1	INTRODUCTION.....	1-1
1.2	FEATURES	1-1
1.3	SPECIFICATIONS	1-2
1.4	GENERAL DESCRIPTION.....	1-3
1.5	EQUIPMENT REQUIRED	1-4

CHAPTER 2 HARDWARE PREPARATION AND INSTALLATION

2.1	INTRODUCTION.....	2-1
2.2	UNPACKING INSTRUCTIONS.....	2-1
2.3	HARDWARE PREPARATION.....	2-1
2.3.1	Reset Select Header (J1).....	2-2
2.3.2	Clock Select Header (J2)	2-3
2.3.3	Memory Select Headers (J3 and J7)	2-4
2.3.4	Program Execution Select Header (J4).....	2-5
2.3.5	Terminal Baud Rate Select Header (J5).....	2-6
2.3.6	Host Port RX Signal Disable Header (J6).....	2-7
2.4	INSTALLATION INSTRUCTIONS	2-7
2.4.1	Power Supply - EVB Interconnection	2-7
2.4.2	Terminal - EVB Interconnection	2-8
2.4.3	Host Computer - EVB Interconnection	2-9
2.4.4	Target System - EVB Interconnection.....	2-11
2.5	CHECKOUT PROCEDURE.....	2-14

CHAPTER 3 MONITOR PROGRAM

3.1	INTRODUCTION.....	3-1
3.2	PROGRAM DESCRIPTION.....	3-1
3.2.1	Initialization.....	3-1
3.2.2	Command Interpreter.....	3-2
3.2.3	I/O Routines.....	3-2
3.2.4	Utility Subroutines.....	3-3
3.2.5	Command Table.....	3-5
3.3	INTERRUPT VECTORS.....	3-5

CHAPTER 4 OPERATING INSTRUCTIONS

4.1	INTRODUCTION.....	4-1
4.2	CONTROL SWITCH.....	4-1
4.3	LIMITATIONS.....	4-1
4.4	OPERATING PROCEDURES.....	4-3
4.4.1	Debugging Mode.....	4-3
4.4.2	Evaluation Mode.....	4-3
4.4.3	Monitor Program.....	4-3
4.5	COMMAND LINE FORMAT.....	4-4
4.6	MONITOR COMMANDS.....	4-5
4.6.1	Assembler/Disassembler.....	4-8
4.6.2	Block Fill.....	4-11
4.6.3	Breakpoint Set.....	4-12
4.6.4	Bulk.....	4-14
4.6.5	Bulkall.....	4-15
4.6.6	Call.....	4-16
4.6.7	EEPROM Modify Mapping.....	4-18
4.6.8	Go.....	4-19
4.6.9	Help.....	4-20
4.6.10	Load.....	4-21
4.6.11	Memory Display.....	4-22
4.6.12	Memory Modify.....	4-23

CHAPTER 4 OPERATING INSTRUCTIONS (continued)

4.6.13	Move	4-25
4.6.14	Proceed/Continue	4-26
4.6.15	Register Modify	4-27
4.6.16	Stop at Address	4-28
4.6.17	Trace	4-29
4.6.18	Transparent Mode.....	4-30
4.6.19	Verify	4-31
4.6.20	Transfer Data Bootstrap Mode.....	4-32
4.7	ASSEMBLY/DISASSEMBLY PROCEDURES	4-34
4.8	DOWNLOADING PROCEDURES.....	4-39
4.8.1	EXORciser to EVB.....	4-40
4.8.2	Apple Macintosh (with MacTerminal) to EVB	4-41
4.8.3	Apple Macintosh (with Red Ryder) to EVB	4-43
4.8.4	IBM-PC (with KERMIT) to EVB.....	4-44
4.8.5	IBM-PC (with PROCOMM) to EVB	4-45

CHAPTER 5 HARDWARE DESCRIPTION

5.1	INTRODUCTION.....	5-1
5.2	GENERAL DESCRIPTION.....	5-1
5.2.1	Microcomputer	5-1
5.2.2	Port Replacement Unit.....	5-2
5.2.3	Memory.....	5-4
5.2.4	Address Decoding/De-multiplexing.....	5-4
5.2.5	RS-232C I/O Port Interface Circuits	5-4

CHAPTER 6 SUPPORT INFORMATION

6.1	INTRODUCTION.....	6-1
6.2	CONNECTOR SIGNAL DESCRIPTIONS	6-1
6.3	PARTS LIST.....	6-7
6.4	DIAGRAMS.....	6-11

APPENDIX A S-RECORD INFORMATION

A.1 INTRODUCTION.....	A-1
A.2 S-RECORD CONTENT.....	A-1
A.3 S-RECORD TYPES.....	A-2
A.4 S-RECORD CREATION.....	A-3
A.5 S-RECORD EXAMPLE.....	A-3

APPENDIX B APPLICATIONS

B.1 INTRODUCTION.....	B-1
-----------------------	-----

FIGURES

1-1. EVB Block Diagram.....	1-4
2-1. EVB Connector, Switch, and Jumper Header Location Diagram.....	2-2
2-2. Terminal/Host Computer Cable Assembly Diagram.....	2-10
2-3. MCU I/O Port Extension Cable Assembly Diagram.....	2-13
5-1. EVB Block Diagram.....	5-2
5-2. EVB Memory Map Diagram.....	5-3
6-1. EVB Parts Location Diagram.....	6-7
6-2. EVB Schematic Diagram (Sheet 1 of 2).....	6-11
6-3. EVB Schematic Diagram (Sheet 2 of 2).....	6-12
B-1. Single-Chip Mode Configuration.....	C-2

TABLES

1-1. EVB Specifications	1-2
1-2. External Equipment Requirements	1-4
3-1. Utility Subroutine Jump Table.....	3-3
3-2. Interrupt Vector Jump Table.....	3-6
4-1. Monitor Memory Map Limitations	4-2
4-2. Monitor Program Commands.....	4-6
6-1. MCU I/O Port Connector (P1) Pin Assignments	6-2
6-2. Terminal I/O Port Connector (P2) Pin Assignments	6-4
6-3. Host I/O Port Connector (P3) Pin Assignments.....	6-5
6-4. Input Power Connector (P4) Pin Assignments.....	6-6
6-5. EVB Parts List.....	6-8

CHAPTER 1

GENERAL INFORMATION

1.1 INTRODUCTION

This manual provides general information, hardware preparation, installation instructions, monitor program description, operating instructions, hardware description, and support information for the M68HC11 Evaluation Board (EVB).

Downloading S-record information is contained in Appendix A. While a listing of the EVB monitor program is stored on the diskettes supplied with the EVB (see file buf25.asm). (This file may be viewed using any text reader capable of handling a 123K file.)

NOTE

Unless otherwise specified, all address references are in hexadecimal throughout this manual.

An asterisk (*) following the signal name denotes that the signal is true or valid when the signal is low.

1.2 FEATURES

EVB features include:

- An economical means of debugging user assembled code and evaluating target systems incorporating MC68HC11 microcomputer unit (MCU) device
- One-line assembler/disassembler
- Host computer downloading capability
- MC68HC11 MCU based debugging/evaluating circuitry
- MC68HC24 Port Replacement Unit (PRU) based MCU I/O expansion circuitry
- MC6850 Asynchronous Communications Interface Adapter (ACIA) based terminal I/O port circuitry
- RS-232C compatible terminal/host computer I/O ports

1.3 SPECIFICATIONS

Table 1-1 lists the EVB specifications.

Table 1-1. EVB Specifications

Characteristics	Specifications
MCU	MC68HC11A1FN
PRU	MC68HC24FN
ACIA	MC68B50
I/O ports: Terminal Host computer MCU extension	RS-232C compatible RS-232C compatible HCMOS-TTL compatible
Temperature: Operating Storage	+25 degrees C -40 to +85 degrees C
Relative humidity	0 to 90% (non-condensing)
Power requirements	+5 Vdc @ 0.5 A (max) +12 Vdc @ 0.1 A (max) -12 Vdc @ 0.1 A (max)
Dimensions: Width Length	7.062 in. (17.8 cm) 4.625 in. (11.75 cm)

1.4 GENERAL DESCRIPTION

The MC68HC11 MCU device is an advanced single-chip MCU with on-chip memory and peripheral functions. Refer to the MC68HC11 MCU data sheet for additional device information. To demonstrate the capabilities of this MCU, the EVB functions with a debug monitor program called BUFFALO (Bit User Fast Friendly Aid to Logical Operations). This monitor program is contained within an on-board EPROM (external to the MCU).

The EVB provides a low cost tool for debugging and evaluation of MC68HC11 MCU-based target system equipment (Figure 1-1 is a block diagram of the EVB). The EVB is not intended to be a replacement for a much more powerful and flexible tool, such as the Motorola M68HC11EVM Evaluation Module. The EVB operates in either the debugging or evaluation (emulation) mode of operation.

The first mode of operation lets you debug your code using the BUFFALO monitor program. User code is assembled on the EVB or on a host computer and then downloaded to the EVB RAM via Motorola S-records. The second mode of operation lets you evaluate (emulate) user code in a target system environment utilizing the memory of the MC68HC11 MCU. The EVB emulates the single-chip mode of operation, even though the EVB operates in the expanded multiplexed mode of operation at all times.

Overall evaluation/debugging control of the EVB is provided by the BUFFALO monitor program via terminal interaction. The target system interface is provided by the MCU and PRU devices. RS-232C terminal/host I/O port interface circuitry provides communication and data transfer operations between the EVB and external terminal/host computer devices.

Independent baud rate selection capabilities are provided for the terminal and host I/O ports. Hardware selectable (300-9600) baud rates are provided for the ACIA-based terminal port. A non-selectable (fixed) 9600 baud rate is provided for the host port via the MCU Serial Communications Interface (SCI).

The EVB requires a user-supplied +5, +12, and -12 Vdc power supply and an RS-232C compatible terminal for operation. An RS-232C compatible host computer is used with the EVB to download Motorola S-records via the BUFFALO monitor commands.

The Motorola S-record format was devised for the purpose of encoding programs or data files in a printable format for transportation between computer systems. The transportation process can therefore be monitored and the S-records can be easily edited. Refer to Appendix A for additional S-record information.

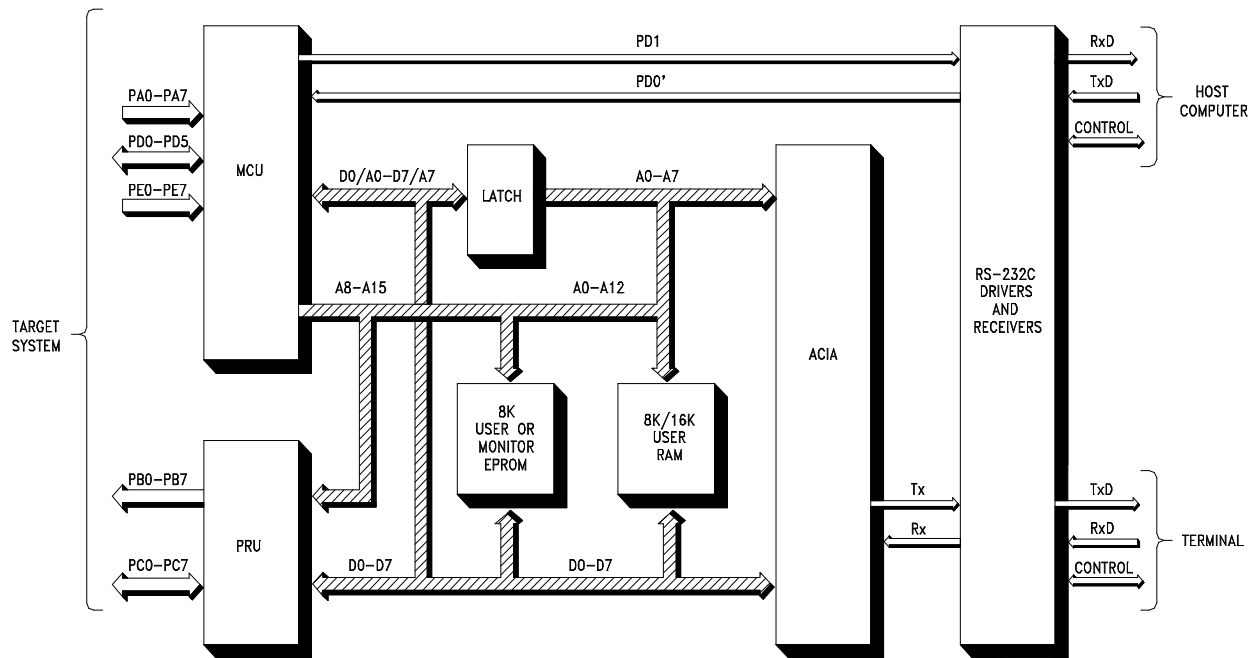

Figure 1-1. EVB Block Diagram

1.5 EQUIPMENT REQUIRED

Table 1-2 lists the external equipment requirements for EVB operation.

Table 1-2. External Equipment Requirements

External Equipment
+5, +12, -12 Vdc power supply ⁽¹⁾
Terminal (RS-232C compatible)
Host computer (RS-232C compatible) ⁽²⁾
Terminal/host computer - EVB RS-232C cable assembly ⁽¹⁾
Target system - EVB MCU I/O port extension cable assembly ⁽¹⁾

1. Refer to Chapter 2 for details.
2. Optional - not required for basic operation

CHAPTER 2

HARDWARE PREPARATION AND INSTALLATION

2.1 INTRODUCTION

This chapter provides unpacking instructions, hardware preparation, and installation instructions for the EVB.

2.2 UNPACKING INSTRUCTIONS

After unpack EVB from shipping carton, refer to the packing list and verify that all items are present. Save packing material for storing or reshipping the EVB.

2.3 HARDWARE PREPARATION

This section describes the inspection/preparation of EVB components prior to target system installation. This description ensures that the EVB components are properly configured for target system operation. The EVB has been factory-tested and is shipped with factory-installed jumpers.

Inspect the EVB for jumper placements prior to target system installation. Figure 2-1 illustrates the EVB connector, switch, and jumper header locations.

Use connector P1 to connect the EVB to the target system. Use connectors P2 and P3 to connect the EVB to the external terminal and host computer equipment, respectively. Use connector P4 to connect an external power supply to the EVB. Use switch S1 to reset the EVB. Jumper header locations J1 through J7 provide these capabilities:

- Reset select (J1)
- Clock select (J2)
- Memory select (J3 and J7)
- Program execution select (J4)
- Terminal baud rate select (J5)
- Host port RX signal disable (J6)

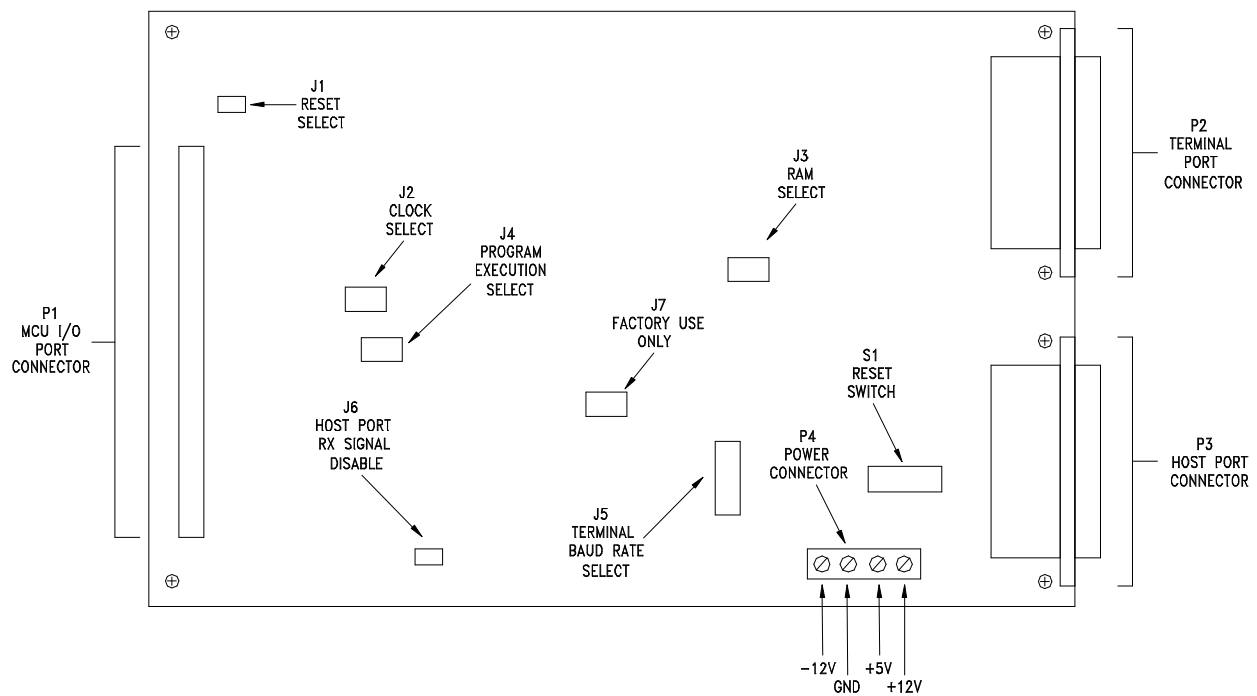
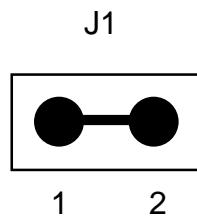

Figure 2-1. EVB Connector, Switch, and Jumper Header Location Diagram

2.3.1 Reset Select Header (J1)

Jumper header J1 is used to connect an external reset signal from the target system (via MCU I/O port connector P1, pin 17) to be used by the EVB. This is accomplished by the installation of a fabricated jumper on pins 1 and 2. The EVB is factory-configured and shipped with the jumper installed as shown below.



This jumper is removed from pins 1 and 2 when the EVB reset circuitry is used without target system intervention.

2.3.2 Clock Select Header (J2)

Jumper header J2 is used to select either internal or external clock source to be used by the EVB. The internal EVB clock source is an 8 MHz crystal for a bus rate of 2 MHz. The EVB is factory-configured and shipped with the clock input selected for internal clock source. This is accomplished by the installation of a fabricated jumper on pins 2 and 3 as shown below.

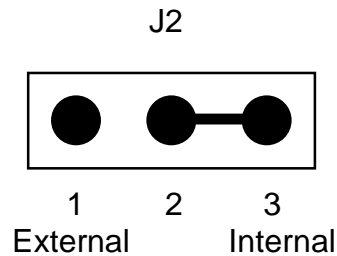

If an external TTL clock source from the target system (via MCU I/O port connector P1, pin 7) is required, the jumper is repositioned between pins 1 and 2.

2.3.3 Memory Select Headers (J3 and J7)

Jumper headers J3 and J7 are used to configure the EVB circuitry for an additional 8k memory device (e.g., MCM6164) installed at location U4. This device is provided by the user if required. If a RAM device is installed at location U4, a fabricated jumper is installed on pins 1 and 2 of jumper header J3 or J7 as shown below.

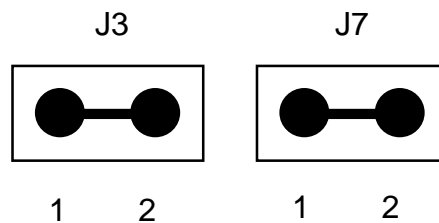

NOTE

Jumper headers J3 and J7 should not have fabricated jumpers installed at the same time.

Jumper header J7 is for factory use only.

Jumper header J3 or J7 applies a chip enable (CE*) signal to the RAM device installed at location U4. The RAM device is selected or deselected by the installation of a fabricated jumper on either jumper header J3 or J7. If the installed RAM device is not required, but left installed, both jumper headers J3 and J7 should not have fabricated jumpers installed.

Installing a fabricated jumper on jumper header J3 causes the memory device at location U4 to be mapped at locations \$6000 to \$7FFF. Installing a fabricated jumper on jumper header J7 causes the memory device located at location U4 to be mapped at locations \$A000 to \$BFFF.

NOTE

MCU EEPROM may be located at \$B600 to \$B7FF.

2.3.4 Program Execution Select Header (J4)

Jumper header J4 is used to determine whether the BUFFALO monitor prompt will be displayed, or if a jump to internal EEPROM will be executed. Upon reset, the monitor detects the state of the PE0 line. If a low state is detected, the monitor program is executed and the prompt displayed. If a high state is detected, the monitor will automatically jump directly to EEPROM (address location \$B600) and execute user program code without displaying the monitor prompt.

The EVM is factory-configured and shipped with the program execution selected for BUFFALO monitor operation as shown below. The user must configure the EVB for the type of program execution required. If program execution out of EEPROM is desired, the jumper is repositioned between pins 2 and 3.

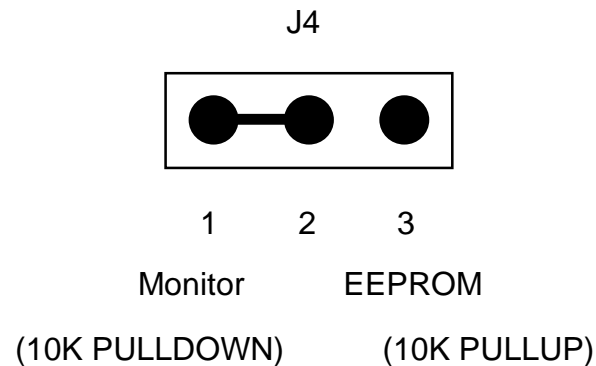

If the PE0 line is used for A/D operations, the loading condition introduced by jumper header J4 may not be desired. To circumvent this condition, program the first three EEPROM locations with \$7E, \$E0, and \$0A, respectively. Next, remove installed jumper from jumper header J4 (removes load condition), and proceed into the A/D operation.

For additional information pertaining to the EEPROM jump operation described above, refer to the buf25.asm file on the EVB diskettes.

2.3.5 Terminal Baud Rate Select Header (J5)

Jumper header J5 is used to select the baud rate for the terminal (P2) I/O port. The EVB is factory configured and shipped with the terminal baud rate selected for 9600 baud as shown below.

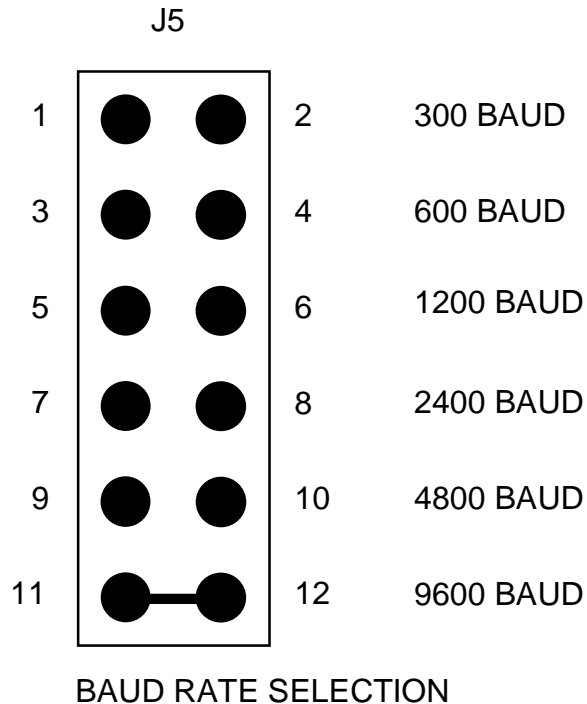

The host (P3) I/O port is a fixed MCU SCI 9600 baud rate (non selectable). Refer to Chapter 6 EVB parts list notes for additional information pertaining to the host baud rate (crystal vs E-clock vs MCU SCI operation).

2.3.6 Host Port RX Signal Disable Header (J6)

Jumper header J6 is used to disable the host computer I/O port RX output signal line (connector P3, pin 2) when using the EVB MCU SCI in a target system application. When performing a downloading operation or communicating to a host computer in the transparent mode, a fabricated jumper is installed on pins 1 and 2 as shown below.

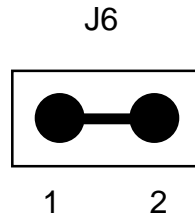

Signal disabling is accomplished by the removal of the fabricated jumper installed on pins 1 and 2.

2.4 INSTALLATION INSTRUCTIONS

The EVB is designed for table top operation. A user supplied power supply and RS-232C compatible terminal are required for EVB operation. An RS-232C compatible host computer is optional for downloading user assembled code to the EVB.

2.4.1 Power Supply - EVB Interconnection

The EVB requires +5 Vdc @ 0.5 A, +12 Vdc @ 0.1 A, -12 Vdc @ 0.1 A, and GND for operation. Interconnection of the power supply wiring to the EVB power supply connector P4 is shown below.

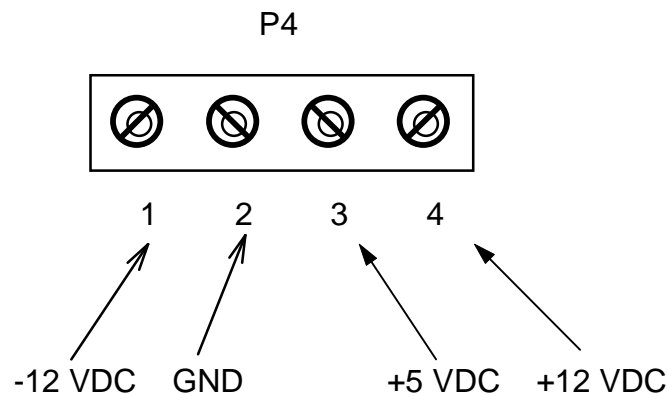

The power supply cable simply consists of four 14-22 AWG wires that interconnect -12 VDC, GND, +5 VDC, and +12 VDC, from the user supplied power supply to the EVB connector P4.

2.4.2 Terminal - EVB Interconnection

Interconnection of an RS-232C compatible terminal to the EVB is accomplished via a user supplied 20 or 25 conductor flat ribbon cable assembly as shown in Figure 2-2. One end of the cable assembly is connected to the EVB connector P2 (shown below). The other end of the cable assembly is connected to the user supplied terminal. For connector pin assignments and signal descriptions of the EVB terminal port connector P2, refer to Chapter 6.

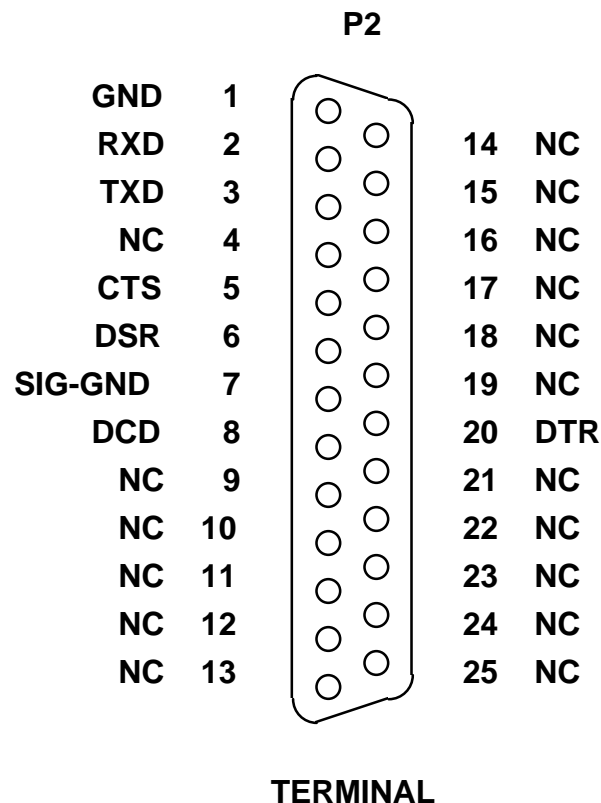

NOTE

A dumb terminal or personal computer is always connected to the terminal I/O port but it is very common not to have any external equipment connected to the host I/O port.

2.4.3 Host Computer - EVB Interconnection

Interconnection of an RS-232C compatible host computer to the EVB is accomplished via a user supplied 20 or 25 conductor flat ribbon cable assembly as shown in Figure 2-2. One end of the cable assembly is connected to the EVB connector P3 (shown below). The other end of the cable assembly is connected to the user supplied host computer. For connector pin assignments and signal descriptions of the EVB host port connector P3, refer to Chapter 6.

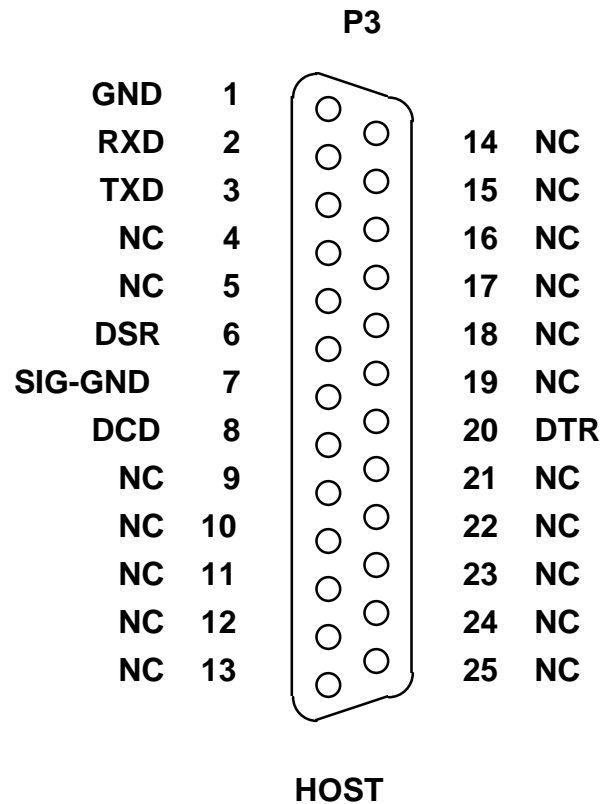

NOTE

The RXD and TXD signal directions (output versus input) are reversed as compared to the terminal I/O port.. The EVB looks like a terminal device to the host "computing" device, while the EVB is a computing device to a terminal device even when the terminal device happens to be a personal computer such as an IBM-PC or a Macintosh computer.

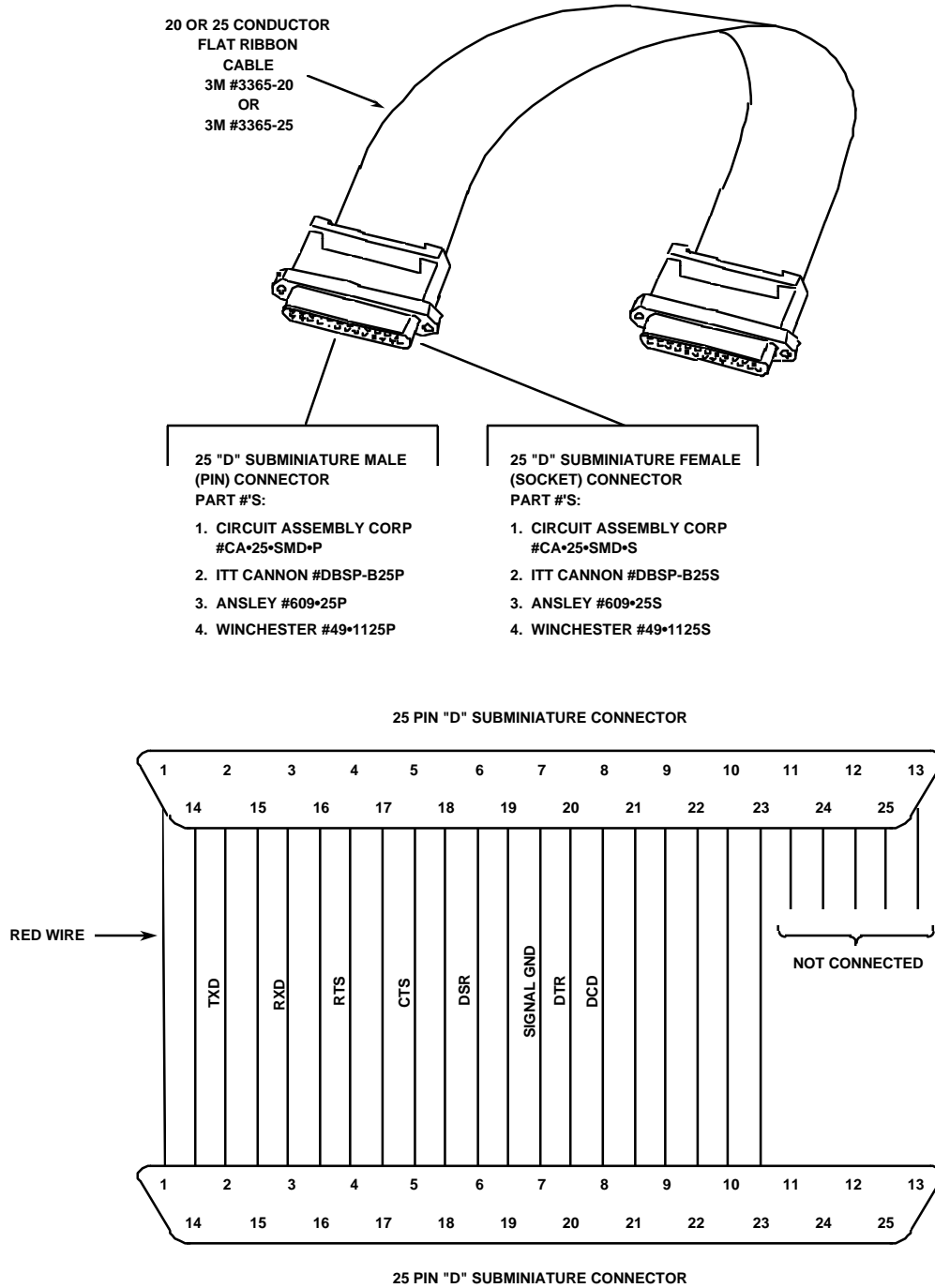

Figure 2-2. Terminal/Host Computer Cable Assembly Diagram

The EVB can operate with only pins 2, 3, and 7 (TXD, RXD, and SIGNAL GND) connected, however; the terminal device may need the other handshake lines for proper operation.

2.4.4 Target System - EVB Interconnection

Target system to EVB interconnection is accomplished via the EVB MCU I/O port connector and a 60 conductor flat ribbon extension cable assembly. This MCU I/O port connector P1 (shown on the following page) is a 60-pin header that facilitates the interconnection of the cable assembly for evaluation purposes. For connector pin assignments and signal descriptions of the EVB MCU I/O port connector P1, refer to Chapter 6.

Two types of extension cable assembly construction techniques are available to the user. Cable assembly construction is dependent upon the purpose or use of the EVB. The user must first determine the primary application of the EVB in order to determine the type of cable assembly to be constructed. Cable assembly types and construction methods are described in the following paragraphs.

The first type of cable assembly (user supplied) is low cost and simplest to construct, and is illustrated in Figure 2-3. This type of assembly provides an indirect connection of the EVB MCU I/O port to the target system MCU device socket. Indirect connection is accomplished via a 60-pin connector, installed on the target system board, that connects to the target system MCU device socket. This connector is a double row post, 60-pin header type, Amptronics # 929715-01-30. Target system wiring from the connector to the MCU device socket is implemented via wire wrap or Printed Wiring Board (PWB) conductive land wiring. Uses for this type of cable assembly are in the early development stages of the MC68HC11 MCU-based product.

The second type of cable assembly (not illustrated) is expensive and hardest to construct. This type of assembly provides a direct connection of the EVB MCU I/O port to the target system MCU device socket. Direct connection is accomplished via a specialized plug platform containing a 52-lead plastic leaded chip carrier (PLCC) plug constructed by the user. This type of plug platform mates directly with the target system MCU device socket. Uses for this type of cable assembly are in the production stages of the developed MC68HC11 MCU-based product.

P1

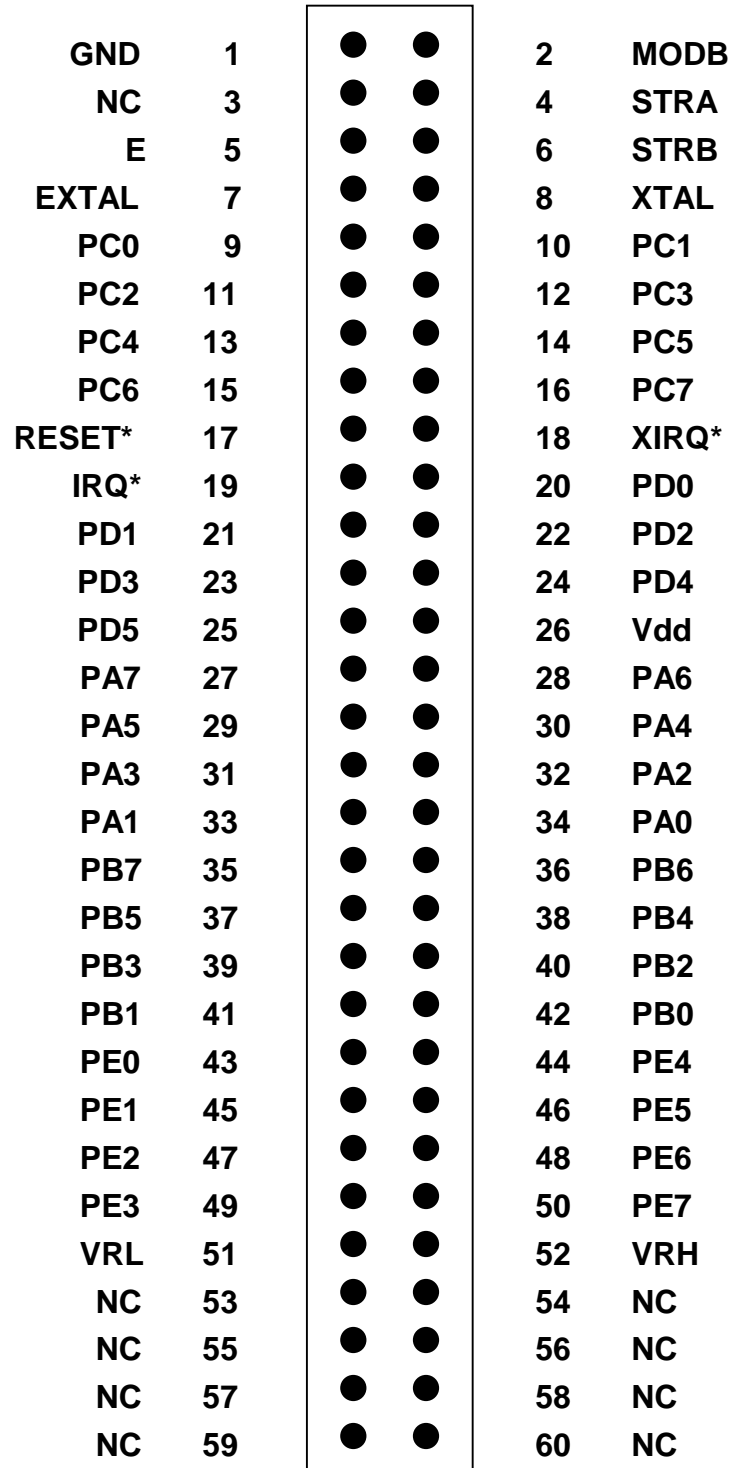

MCU I/O PORT

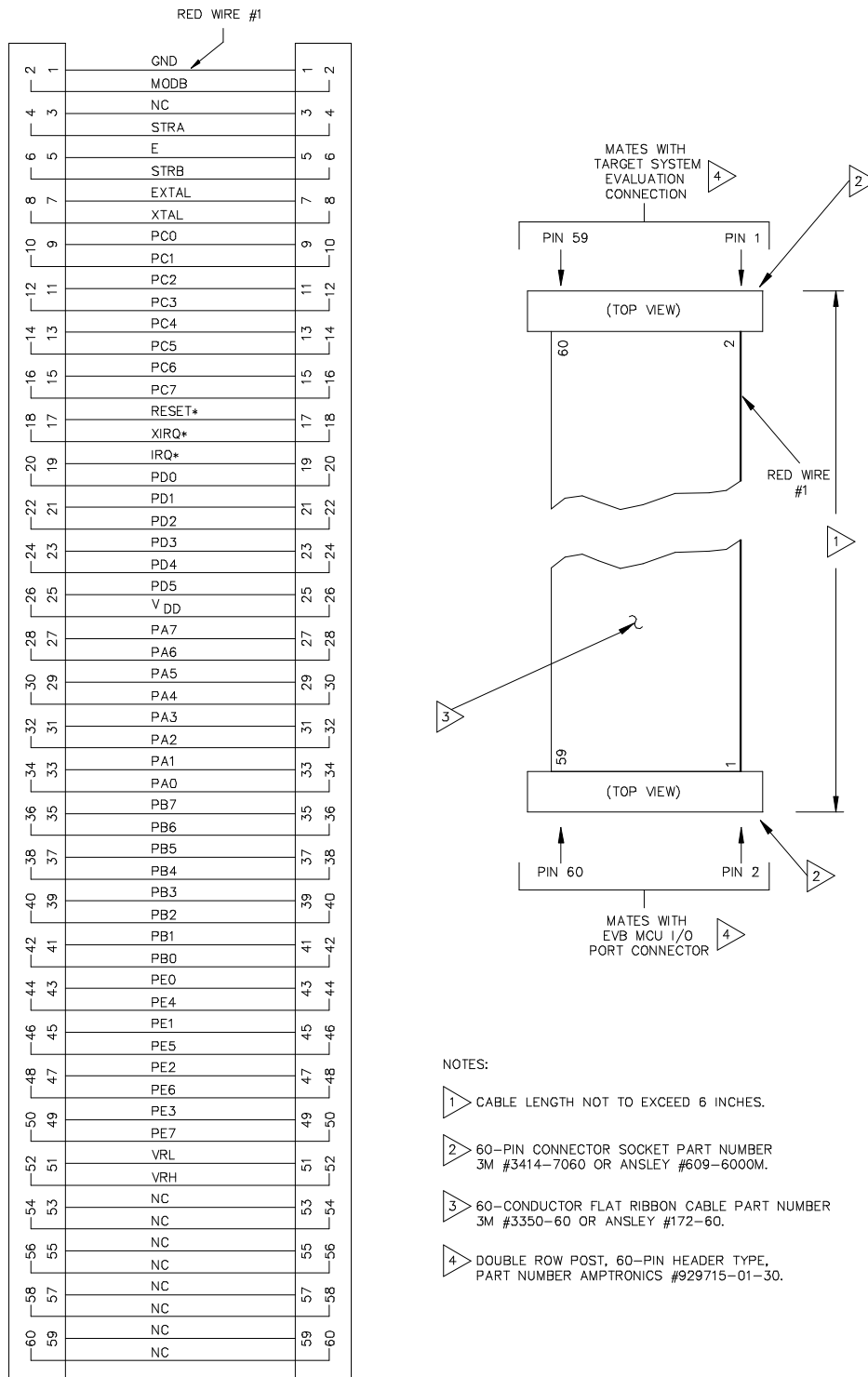

Figure 2-3. MCU I/O Port Extension Cable Assembly Diagram

2.5 CHECKOUT PROCEDURE

This procedure lets you perform a pre-operational checkout of the EVB for basic operation. Upon completion of the EVB installation to an external power supply and terminal, check that the EVB is configured for the proper terminal baud rate (refer to paragraph 2.3.5.).

Applying power to the EVB causes a power-on reset (POR) to occur. POR causes the MCU and user I/O port circuitry to be reset, and the monitor invoked. The terminal monitor displays the following EVB monitor prompt:

BUFFALO X.X (ext) - Bit User Fast Friendly Aid to Logical Operation

where:

X.X is the revision of the monitor program.

(ext) denotes monitor program residing in external EPROM (U3).

(int) denotes monitor program residing in EEPROM MCU (U10).

If the EVB monitor prompt is not displayed (as shown above), press the user reset switch S1. If the monitor prompt cannot be displayed, the possibility exists that the EVB cannot communicate via the terminal port because the CONFIG register NOSEC bit is enabled (logic 0). Erasing the entire EEPROM array including the CONFIG register must be performed as follows:

1. Remove installed jumper from reset select header J1. Reinstall jumper on MCU I/O port connector P1, pins 1 and 2 (top two pins).
2. Press reset switch S1.
3. Remove installed jumper from connector P1. Reinstall jumper on header J1 (pins 1 and 2).
4. Press reset switch S1. Internal (int) BUFFALO monitor prompt is displayed.
5. Memory modify (MM) command (refer to paragraph 4.6.11) is used to change CONFIG register contents to \$0D. BUFFALO monitor will respond with "rom" message.
6. Press reset switch S1. External (ext) BUFFALO monitor prompt is displayed.

Proceed to Chapter 4 for complete operating instructions.

CHAPTER 3

MONITOR PROGRAM

3.1 INTRODUCTION

This chapter provides the overall description of the monitor program. This description will enable the user to understand the basic structure of the program, and to modify or customize the program for specific applications.

3.2 PROGRAM DESCRIPTION

The monitor program supplied for the EVB is called BUFFALO (Bit User Fast Friendly Aid to Logical Operations). This program communicates via the MC6850 Asynchronous Communications Interface Adapter (ACIA) device and the MCU Serial Communications Interface (SCI). Refer to the buf25.asm file on the EVB diskettes for additional information pertaining to the monitor (BUFFALO) program.

The EVB monitor program is contained in EPROM (external to the MCU). The EVB resident MCU have the configuration (CONFIG) register ROMON bit cleared thereby disabling the MCU internal ROM. Having the monitor program in EPROM external to the MCU at locations \$E000-\$FFFF is a great advantage because it allows the user to add instructions to customize the monitor for specific requirements.

The BUFFALO monitor program consists of five parts (or sections) which are as follows:

- Initialization
- Command interpreter
- I/O routines
- Utility subroutines
- Command table

3.2.1 Initialization

This part of BUFFALO contains all of the reset initialization code. In this section, internal RAM locations are set up, and the I/O channel for the terminal is set up. To set up the terminal I/O port, BUFFALO must determine if the terminal is connected to the SCI or to an external ACIA or DUART. This is accomplished by sending a sign-on message to all ports and then waiting for the user to type carriage return (RETURN) on whichever device is the terminal port. When

BUFFALO recognizes a carriage return from a port, that port is then used for all subsequent terminal I/O operations.

3.2.2 Command Interpreter

The next section of BUFFALO is the command interpreter. American Standard Code for Information Interchange (ASCII) characters are read from the terminal into the input buffer until a carriage return or a slash (/) is received. The command field is then parsed out of the input buffer and placed into the command buffer. A table of commands is then searched and if a match is found, the corresponding command module is called as a subroutine. All commands return control back to the command interpreter upon completion of the operation.

3.2.3 I/O Routines

The I/O section of BUFFALO consists of a set of supervisor routines, and three sets of driver routines. The supervisor routines are INIT, INPUT, and OUTPUT. These routines determine which driver subroutine to call to perform the specific action. Each set of driver routines consists of an initialization routine, an input routine, and an output routine. One set of drivers is for the SCI port and these routines are called ONSCI, INSCI, and OUTSCI. The second set of drivers is for a DUART and these routines are called ONUART, INUART, and OUTUART. The third set of drivers is for an ACIA and these routines are called ONACIA, INACIA, and OUTACIA.

All I/O communications are controlled by three RAM locations (IODEV, EXTDEV, and HOSTDEV). EXTDEV specifies the external device type (0=none, 1=ACIA, 2=DUART). HOSTDEV specifies which I/O port is used for host communications (0=SCI, 1=ACIA, 3=DUARTB). IODEV instructs the supervisor routine which port/driver routine to use (0=SCI, 1=ACIA, 2=DUART, 3=DUARTB).

The INIT routines set up a serial transmission format of eight data bits, one stop bit, and no parity. For the SCI, the baud rate is set to 9600 for an 8 MHz crystal (2 MHz E-clock). A different baud rate can be achieved by modifying address location \$102B (refer to MCU data sheet, SCI baud rate selection).

The INPUT routine reads from the specified port. If a character is received, the character is returned in accumulator A. If no character is received a zero (0) is returned in accumulator A. This routine does not wait for a character to be received before returning (function is performed by the INCHAR subroutine).

The OUTPUT routine takes the ASCII character in accumulator A and writes to the specified I/O port. This routine waits until the character is transmitted before returning.

3.2.4 Utility Subroutines

Several subroutines exist that are available for performing I/O tasks. A jump table has been set up in ROM directly before the interrupt vectors. To use these subroutines, execute a jump to subroutine (JSR) command to the appropriate entry in the jump table. By default, all I/O performed with these routines are sent to the terminal port. Redirection of the I/O port is achieved by placing the specified value (0=SCI, 1=ACIA, 2=DUARTA, 3=DUARTB) into RAM location IODEV.

Utility subroutines available to the user are listed in Table 3-1.

Table 3-1. Utility Subroutine Jump Table

Address	Routine	Description
\$FF7C	.WARMST	Go to ">" prompt point (skip BUFFALO... message).
\$FF7F	.BPCLR	Clear breakpoint table.
\$FF82	.RPRINT	Display user's registers.
\$FF85	.HEXBIN	Convert ASCII character in A register to 4-bit binary number. Shift binary number into SHFTREG from the right. SHFTREG is a 2-byte (4 hexadecimal digits) buffer. If A register is not hexadecimal, location TMP1 is incremented and SHFTREG is unchanged.
\$FF88	.BUFFAR	Read 4-digit hexadecimal argument from input buffer to SHFTREG.
\$FF8B	.TERMAR	Read 4-digit hexadecimal argument from terminal device to SHFTREG.
\$FF8E	.CHGBYT	Write value (if any) from SHFTREG+1 to memory location pointed to by X. (Operation also applicable to EEPROM locations.)
\$FF91	.READBU	Read next character from INBUFF.
\$FF94	.INCBUF	Increment pointer into input buffer.
\$FF97	.DECBUF	Decrement pointer into input buffer.
\$FF9A	.WSKIP	Read input buffer until non-white-space character found.
\$FF9D	.CHKABR	Monitor input for (CTRL)X, (DELETE), or (CTRL)W requests.
\$FFA0	.UPCASE	If character in accumulator A is lower case alpha, convert to upper case.

Table 3-1. Utility Subroutine Jump Table (continued)

Address	Routine	Description
\$FFA3	.WCHEK	Test character in accumulator A and return with Z bit set if character is white space (space, comma, tab).
\$FFA6	.DCHEK	Test character in accumulator A and return with Z bit set if character is delimiter (carriage return or white space).
\$FFA9	.INIT	Initialize I/O device.
\$FFAC	.INPUT	Read I/O device.
\$FFAF	.OUTPUT	Write I/O device.
\$FFB2	.OUTLHL	Convert left nibble of accumulator A contents to ASCII and output to terminal port.
\$FFB5	.OUTRHL	Convert right nibble of accumulator A contents to ASCII and output to terminal port.
\$FFB8	.OUTA	Output accumulator A ASCII character.
\$FFBB	.OUT1BY	Convert binary byte at address in index register X to two ASCII characters and output. Returns address in index register X pointing to next byte.
\$FFBE	.OUT1BS	Convert binary byte at address in index register X to two ASCII characters and output followed by a space. Returns address in index register X pointing to next byte.
\$FFC1	.OUT2BS	Convert two consecutive binary bytes starting at address in index register X to four ASCII characters and output followed by a space. Returns address in index register X pointing to next byte.
\$FFC4	.OUTCRL	Output ASCII carriage return followed by a line feed.
\$FFC7	.OUTSTR	Output string of ASCII bytes pointed to by address in index register X until character is an end of transmission (\$04).
\$FFCA	.OUTST0	Same as OUTSTR except leading carriage return and line feed is skipped.
\$FFCD	.INCHAR	Input ASCII character to accumulator A and echo back. This routine loops until character is actually received.
\$FFD0	.VECINIT	Used during initialization to preset indirect interrupt vector area in RAM. This routine or a similar routine should be included in a user program which is invoked by the jump to \$B600 feature of BUFFALO.

When accessing BUFFALO utility routines, always reference the routines by the applicable address (\$FF7C through \$FFD0) in the jump table rather than the actual address in the BUFFALO monitor program. Jump table addresses remain the same when a new version of BUFFALO is developed even though the actual addresses of the routine may change. Programs that reference routines by the jump table addresses are not required to be changed to operate on revised versions of the BUFFALO monitor program.

3.2.5 Command Table

The command table consists of three lines for each entry. The first byte is the number of characters in the command name. The second entry is the ASCII command name. The third entry is the starting address of the command module. As an example:

```
FCB  3          3 characters in command name
FCC  'ASM'      ASCII literal command name string
FDB  #ASM      Jump address for command module
```

Each command in the BUFFALO program is a individual module. Thus, to add or delete commands, all that is required is to include a new command module or delete an existing module and/or delete the entry in the command table.

3.3 INTERRUPT VECTORS

Interrupt vectors residing in MCU internal ROM are accessible as follows. Each vector is assigned a three byte field residing in EVB memory map locations \$0000-\$00FF. This is where the monitor program expects the MCU RAM to reside. Each vector points to a three byte field which is used as a jump table to the vector service routine. Table 3-2 lists the interrupt vectors and associated three byte field.

Table 3-2. Interrupt Vector Jump Table

Interrupt Vector	Field
Serial Communications Interface (SCI)	\$00C4 - \$00C6
Serial Peripheral Interface (SPI)	\$00C7 - \$00C9
Pulse Accumulator Input Edge	\$00CA - \$00CC
Pulse Accumulator Overflow	\$00CD - \$00CF
Timer Overflow	\$00D0 - \$00D2
Timer Output Compare 5	\$00D3 - \$00D5
Timer Output Compare 4	\$00D6 - \$00D8
Timer Output Compare 3	\$00DC - \$00DE
Timer Output Compare 1	\$00DF - \$00E1
Timer Input Capture 3	\$00E2 - \$00E4
Timer Input Capture 2	\$00E5 - \$00E7
Timer Input Capture 1	\$00E8 - \$00EA
Real Time Interrupt	\$00EB - \$00ED
IRQ	\$00EE - \$00F0
XIRQ	\$00F1 - \$00F3
Software Interrupt (SWI)	\$00F4 - \$00F6
Illegal Opcode	\$00F7 - \$00F9
Computer Operating Properly (COP)	\$00FA - \$00FC
Clock Monitor	\$00FD - \$00FF

To use vectors specified in Table 3-2, the user must insert a jump extended opcode in the three byte field of the vector required. For an example, for the IRQ vector, the following is performed:

1. Place \$7E (JMP) at location \$00EE.
2. Place IRQ service routine address at locations \$00EF and \$00F0.

The following is an example where the IRQ service routine starts at \$0100:

```
$00EE  7E  01  00  JMP IRQ SERVICE
```

During initialization BUFFALO checks the first byte of each set of three locations.. If a \$7E jump opcode is not found, BUFFALO will install a jump to a routine called STOPIT. This assures there will be no uninitialized interrupt vectors which would cause undesirable operation during power up and power down. If an interrupt is accidentally encountered, the STOPIT routine will force a STOP instruction sequence to be executed. A user may replace any of the JMP STOPIT instructions with a JMP to a user written interrupt service routine. If reset is issued via switch S1, BUFFALO will not overwrite these user jump instructions so they need not be re-initialized after every reset.



CHAPTER 4

OPERATING INSTRUCTIONS

4.1 INTRODUCTION

This chapter provides the necessary information to initialize and operate the EVB in a target system environment. Information consists of the control switch description, operating limitations, command line format, monitor commands, and operating procedures. The operating procedures consist of assembly/disassembly and downloading descriptions and examples.

4.2 CONTROL SWITCH

The EVB contains a user reset switch S1. This switch is a momentary action push-button switch that resets the EVB MCU circuits.

4.3 LIMITATIONS

CAUTION

Caution should be observed when programming or erasing MCU EEPROM locations. EVB MCU configuration (CONFIG) register ROMON bit is cleared to disable MCU internal ROM, thereby allowing external EPROM containing the BUFFALO program to control EVB operations.

The MC68HC11 MCU SCI has been set for 9600 baud using a 2 MHz E clock external bus. This baud rate can be changed by software by reprogramming the BAUD register in the ONSCI subroutine of the BUFFALO monitor program. Refer to the buf25.asm file on the EVB diskettes for additional information pertaining to the ONSCI subroutine.

As the RS-232C handshake lines are not used, a delay of approximately 300 milliseconds is present between successive characters sent to the host computer during the execution of the LOAD command in the monitor program.

The monitor program uses the MCU internal RAM located at \$0048-\$00FF. The control registers are located at \$1000-\$103F. The monitor program also uses Output Compare 5 (OC5) for the TRACE instruction, therefore OC5 should not be used in user routines being traced.

The EVB allows the user to use all the features of the BUFFALO evaluation software, however it should be noted (when designing code) that the BUFFALO uses the MCU on-chip RAM locations \$0048-\$00FF leaving only 72 bytes for the user (i.e., \$0000-\$0047).

The user must be aware of the BUFFALO monitor address location restrictions. Table 4-1 lists the monitor memory map limitations.

Table 4-1. Monitor Memory Map Limitations

Address	Restrictions
\$0000-\$0047	Available to user. (BUFFALO sets default value of the user stack pointer at location \$0047.)
\$0048-\$0065	BUFFALO monitor stack area.
\$0066-\$00C3	BUFFALO variables.
\$00C4-\$00FF	Interrupt pseudo vectors (jumps).
\$0100-\$01FF	User available.
\$1000-\$103F	MCU control registers. Although RAM and registers can be moved in the memory map, BUFFALO expects RAM at \$0000 (actually requires \$0048-\$00FF) and registers at \$1000-\$103F.
\$4000	<p>Some versions of EVBs have a D flip-flop addressed at this location. During initialization, BUFFALO 3.2 writes \$00 to location \$4000 and various monitor operations cause \$00 or \$01 to be written to \$4000. (Refer to the buf25.asm file on the EVB diskette for the definitions of DFLOP, TARGCO, and HOSTCO for additional information).</p> <p>Since the EVB has no memory or peripherals located at \$4000, these writes should not concern most EVB users.</p>
\$D000-\$D00F	BUFFALO supports serial I/O to a terminal and/or host via a DUART (external IC) located at \$D000 in the memory map. During initialization, BUFFALO 3.2 reads and writes to location \$D00C to see if a DUART is present in the system. Refer to the buf25.asm file on the EVB diskette.

4.4 OPERATING PROCEDURES

The EVB is a simplified debugging/evaluating tool designed to operate in either the debugging or evaluation (emulation) mode of operation. Jumper header J4 is used to determine whether the BUFFALO monitor prompt will be displayed, or if a jump to internal EEPROM will be executed. Refer to paragraph 2.3.4 for additional program execution selection information.

Upon reset, the monitor detects the state of the PE0 line. If a low state is detected, the monitor program is executed and the prompt displayed. If a high state is detected, the monitor will automatically jump directly to EEPROM (address location \$B600) and execute user program code without displaying the monitor prompt.

4.4.1 Debugging Mode

The first mode of operation allows the user to debug user code under control of the monitor program. User code can be assembled in one of two methods. The first method is to assemble code using the line assembler in the BUFFALO monitor program via the EVB user RAM (\$C000-\$DFFF). The second method is to assemble code on a host computer and then download the code to the EVB user RAM via Motorola S-records. The monitor program is then used to debug the assembled user code. Having the monitor program in EPROM external to the MCU (\$E000-\$FFFF) allows the user to add instructions to customize the monitor for specific requirements.

4.4.2 Evaluation Mode

The second mode of operation allows the user to evaluate (emulate) user code in a target system environment utilizing the memory of the MC68HC11 MCU. This is accomplished by relocating the code from locations \$C000-\$DFFF (EVB user RAM) to \$E000-\$FFFF (MCU 8k ROM). MCU locations \$0000-\$00FF (RAM) and \$B600-\$B7FF (EEPROM) are also available to the user. The EVB then emulates an EPROM equivalent of the masked ROM device in the single chip mode of operation. The EVB emulates as if in a single-chip mode of operation, even though operating in the expanded multiplexed mode of operation at all times.

4.4.3 Monitor Program

The monitor BUFFALO program is the resident firmware for the EVB, which provides a self contained operating environment. The monitor interacts with the user through predefined commands that are entered from a terminal. The user can use any of the commands supported by the monitor.

A standard input routine controls the EVB operation while the user types a command line. Command processing begins only after the command line has been terminated by depressing the keyboard carriage return (<CR>) key.

4.5 COMMAND LINE FORMAT

The command line format is as follows:

```
><command> [ <parameters> ]<CR>
```

where:

- > EVB monitor prompt.
- <command> Command mnemonic (single letter for most commands).
- <parameters> Expression or address.
- <CR> ENTER keyboard key - depressed to enter command.

NOTES

1. The command line format is defined using special characters which have the following syntactical meanings:
 - < > Enclose syntactical variable
 - [] Enclose optional fields
 - []... Enclose optional fields repeated

These characters are not entered by the user, but are for definition purposes only.

2. Fields are separated by any number of space, comma, or tab characters.
3. All input numbers are interpreted as hexadecimal.
4. All input commands can be entered either upper or lower case lettering. All input commands are converted automatically to upper case lettering except for downloading commands sent to the host computer, or when operating in the transparent mode.
5. A maximum of 35 characters may be entered on a command line. After the 36th character is entered, the monitor automatically terminates the command entry and the terminal CRT displays the message "Too Long".
6. Command line errors may be corrected by backspacing (CTRL-H) or by aborting the command (CTRL-X or DELETE).
7. After a command has been entered, pressing <CR> a second time will repeat the command.

4.6 MONITOR COMMANDS

The monitor BUFFALO program commands are listed alphabetically by mnemonic in Table 4-2. Each of the commands are described in detail following the tabular command listing. In most cases the initial single letter of the command mnemonic or a specific symbol (shown in Table 4-2) can be used. A minimum number of characters must be entered to at least guarantee uniqueness from other commands (i.e., MO = MOVE, ME = MEMORY). If the letter M is entered, BUFFALO uses the first command in Table 4-2 that starts with M.

Additional terminal keyboard functions are as follows:

(CTRL) A	Exit transparent mode or assembler
(CTRL) B	Send break command to host in transparent mode
(CTRL) H	Backspace
(CTRL) J	Line feed <lf>
(CTRL) W	Wait/freeze screen ⁽¹⁾
(DELETE)	Abort/cancel command
<CR>	Enter command/repeat last command

NOTES

1. Execution is restarted by any terminal keyboard key.
2. When using the control key with a specialized command such as (CTRL)A, the (CTRL) key is depressed and held, then the A key is depressed. Both keys are then released.

Command line input examples in this chapter are amplified with the following:

- Bold entries are user-entered on the terminal keyboard.
- Command line input is entered when the keyboard <CR> key is depressed.

Typical example of this explanation is as follows:

```
>MD F000 F100<CR>
```

Table 4-2. Monitor Program Commands

Command	Description
ASM [<address>]	Assembler/disassembler
<i>ASSEM</i>	<i>(same as ASM)</i>
BF <addr1> <addr2> <data>	Block fill memory with data
BR [-] [<address>]...	Breakpoint set
<i>BREAK</i>	<i>(same as BR)</i>
BULK	Bulk erase EEPROM
<i>BULKA</i>	<i>(same as BULKALL)</i>
BULKALL	Bulk erase EEPROM + CONFIG register ⁽¹⁾
CALL [<address>]	Execute subroutine
<i>COPY</i>	<i>(same as MOVE)</i>
<i>DUMP</i>	<i>(same as MD)</i>
EEMOD	Modify EEPROM mapping
<i>ERASE</i>	<i>(same as BULK)</i>
<i>FILL</i>	<i>(same as BF)</i>
G [<address>]	Execute program
<i>GO</i>	<i>(same as G)</i>
HELP	Display monitor commands
<i>HOST</i>	<i>(same as TM)</i>
LOAD <host download command>	Download (S-records*) via host port ⁽²⁾
LOAD <T>	Download (S-records*) via terminal port ⁽²⁾
<i>MEMORY</i>	<i>(same as MM)</i>
MD [<addr1> [<addr2>]]	Dump memory to terminal
MM [<address>]	Memory modify
MOVE <addr1> <addr2> [<dest>]	Move memory to new location
P	Proceed/continue from breakpoint
<i>PROCEED</i>	<i>(same as P)</i>
<i>RD</i>	<i>(same as RM)</i>

Table 4-2. Monitor Program Commands (continued)

Command	Description
<i>READ</i>	<i>(same as MOVE)</i>
<i>REGISTER</i>	<i>(same as RM)</i>
RM [p,x,y,a,b,c,s]	Register modify/display user registers
STOPAT <address>	Stop at address
T [<n>]	Trace \$1-\$FF instructions
TM	Enter transparent mode
<i>TRACE</i>	<i>(same as T)</i>
VERIFY <host download command>	Compare memory to download data via host port
VERIFY <T>	Compare memory to download data via terminal port
XBOOT [<address1> [<address2>]]	Send program to another M68HC11 via bootstrap mode
?	<i>(same as HELP)</i>
[<address>]/	<i>(same as MM [<address>])</i>

NOTES

1. On newer mask sets of MC68HC11, CONFIG can only be changed in special test or bootstrap modes of operation.
2. * Refer to Appendix A for S-record information.

ASM

Assembler/Disassembler

4.6.1 Assembler/Disassembler

ASM [<address>]

where:

<address> The starting address for the assembler operation. Assembler operation defaults to internal RAM if no address is given.

The assembler/disassembler is an interactive assembler/editor. Each source line is converted into the proper machine language code and is stored in memory overwriting previous data on a line-by-line basis at the time of entry. In order to display an instruction, the machine code is disassembled and the instruction mnemonic and operands are displayed. All valid opcodes are converted to assembly language mnemonics. All invalid opcodes are displayed on the terminal CRT as "ILLOP".

The syntax rules for the assembler are as follows: (a.) All numerical values are assumed to be hexadecimal. Therefore no base designators (e.g., \$ = hex, % = binary, etc.) are allowed. (b.) Operands must be separated by one or more space or tab characters. (c.) Any characters after a valid mnemonic and associated operands are assumed to be comments and are ignored.

Addressing modes are designated as follows: (a.) Immediate addressing is designated by preceding the address with a # sign. (b.) Indexed addressing is designated by a comma. The comma must be preceded a one byte relative offset (even if the offset is 00), and the comma must be followed by an X or Y designating which index register to use (e.g., LDAA 00,X). (c.) Direct and extended addressing is specified by the length of the address operand (1 or 2 digits specifies direct, 3 or 4 digits specifies extended). Extended addressing can be forced by padding the address operand with leading zeros. (d.) Relative offsets for branch instructions are computed by the assembler. Therefore the valid operand for any branch instruction is the branch-if-true address, not the relative offset.

ASM**Assembler/Disassembler**

When a new source line is assembled, the assembler overwrites what was previously in memory. If no new source line is submitted, or if there is an error in the source line, then the contents of memory remain unchanged. Four instruction pairs have the same opcode, so disassembly will display the following mnemonics:

- Arithmetic Shift Left (ASL)/Logical Shift Left (LSL) displays as ASL
- Arithmetic Shift Left Double (ASLD)/Logical Shift Left Double (LSLD) displays as LSLD
- Branch if Carry Clear (BCC)/Branch if Higher or Same (BHS) displays as BCC
- Branch if Carry Set (BCS)/Branch if Lower (BLO) displays as BCS

If the assembler tries to assemble at an address that is not in RAM or EEPROM, an invalid address message "rom-xxxx" is displayed on the terminal CRT (xxxx = invalid address).

Assembler/disassembler subcommands are as follows. If the assembler detects an error in the new source line, the assembler will output an error message and then reopen the same address location.

- / Assemble the current line and then disassemble the same address location.
- ^ Assemble the current line and then disassemble the previous sequential address location.
- <CR> Assemble the current line and then disassemble the next opcode address.
- (CTRL)J Assemble the current line. If there isn't a new line to assemble, then disassemble the next sequential address location. Otherwise, disassemble the next opcode address.
- (CTRL)A Exit the assembler mode of operation.

ASM

Assembler/Disassembler

EXAMPLES	DESCRIPTION
<pre>>ASM C000<CR> C000 STX \$FFFF >LDAA #55<CR> 86 55 C002 STX \$FFFF >STAA C0<CR> 97 C0 C004 STX \$FFFF >LDS 0,X<CR> AE 00 C006 STX \$FFFF >BRA C500<CR></pre>	<p>Immediate mode addressing, requires # before operand.</p> <p>Direct mode addressing.</p> <p>Index mode, if offset = 0 (,X) will not be accepted.</p> <p>Branch out of range message.</p>
<pre>Branch out of range C006 STX \$FFFF >BRA C030<CR> 20 28 C008 STX \$FFFF >(CTRL)A ></pre>	<p>Branch offsets calculated automatically, address required as branch operand.</p> <p>Assembler operation terminated.</p>

NOTE

Above example memory locations \$C000-\$C008 contain \$FF data which disassembles to STX \$FFFF.

Refer to the end of this chapter for additional operational information pertaining to the use of the assembler/disassembler.

BF**Block Fill****4.6.2 Block Fill**

```
BF <address1> <address2> <data>
```

where:

- <address1> Lower limit for fill operation.
- <address2> Upper limit for fill operation.
- <data> Fill pattern hexadecimal value.

The BF command allows the user to repeat a specific pattern throughout a determined user memory range. If an invalid address is specified, an invalid address message "rom-xxxx" is displayed on the terminal CRT (xxxx = invalid address).

EXAMPLES**DESCRIPTION**

```
>BF C000 C030 FF<CR>
```

Fill each byte of memory from C000 through C030 with data pattern FF.

```
>BF C000 C000 0
```

Set location C000 to 0.

BR

Breakpoint Set

4.6.3 Breakpoint Set

```
BR [-][<address>]...
```

where:

- removes (clears) all breakpoints.
- [<address>]... removes individual or multiple addresses from breakpoint table.

The BR command sets the address into the breakpoint address table. During program execution, a halt occurs to the program execution immediately preceding the execution of any instruction address in the breakpoint table. A maximum of four breakpoints may be set. After setting the breakpoint, the current breakpoint addresses, if any, are displayed. Whenever the G, CALL, or P commands are invoked, the monitor program inserts breakpoints into the user code at the address specified in the breakpoint table.

Breakpoints are accomplished by the placement of a software interrupt (SWI) at each address specified in the breakpoint address table. The SWI service routine saves and displays the internal machine state, then restores the original opcodes at the breakpoint location before returning control back to the monitor program.

SWI opcode cannot be executed or breakpointed in user code because the monitor program uses the SWI vector. Only RAM locations can be breakpointed. Branch on self instructions cannot be breakpointed.

COMMAND FORMATS

DESCRIPTION

BR	Display all current breakpoints.
BR <address>	Set breakpoint.
BR <addr1> <addr2> ...	Set several breakpoints.
BR -	Remove all breakpoints.
BR -<addr1> <addr2>...	Remove <addr1> and add <addr2>.
BR <addr1> - <addr2>...	Add <addr1>, clear all entries, then add <addr2>.
BR <addr1> -<addr2>...	Add <addr1>, then remove <addr2>.



BR

Breakpoint Set

EXAMPLES	DESCRIPTION
<pre>>BR C003<CR> C003 0000 0000 0000 ></pre>	Set breakpoint at address location C003.
<pre>>BR C003 C005 C007 C009<CR> C003 C005 C007 C009 ></pre>	Sets four breakpoints. Breakpoints at same address will result in only one breakpoint being set.
<pre>>BR<CR> C003 C005 C007 C009 ></pre>	Display all current breakpoints.
<pre>>BR -C009<CR> C003 C005 C007 0000 ></pre>	Remove breakpoint at address location C009.
<pre>>BR - C009<CR> C009 0000 0000 0000 ></pre>	Clear breakpoint table and add C009.
<pre>>BR -<CR> 0000 0000 0000 0000 ></pre>	Remove all breakpoints.
<pre>>BR E000<CR> rom-E000 0000 0000 0000 0000 ></pre>	Only RAM locations can be breakpointed. Invalid address message.
<pre>>BR C005 C007 C009 C011 C013<CR> Full C005 C007 C009 C011 ></pre>	Maximum of four breakpoints can be set. Buffer full message.

BULK**BULK****4.6.4 Bulk**

The BULK command allows the user to erase all MCU EEPROM locations (\$B600-\$B7FF). A delay loop is built in such that the erase time is about 10 ms when running at 1 MHz E clock.

NOTE

No erase verification message will be displayed upon completion of the bulk EEPROM erase operation. User must verify erase operation by examining EEPROM locations using the MM or MD command.

EXAMPLE

```
>BULK<CR>  
>
```

DESCRIPTION

Bulk erase all MCU EEPROM locations (\$B600-\$B7FF).
Prompt indicates erase sequence completed.

BULKALL

BULKALL

4.6.5 Bulkall

BULKALL

The BULKALL command allows the user to erase all MCU EEPROM locations (\$B600-\$B7FF) including the configuration (CONFIG) register location (\$103F). A delay loop is built in such that the erase time is about 10 ms when running at 1 MHz E clock. This command is only applicable for A38P and A95J mask sets. Newer mask sets do not allow CONFIG to be changed in normal operating modes.

NOTE

No erase verification message will be displayed upon completion of the bulkall EEPROM and configuration register erase operation. User must verify erase operation by examining EEPROM locations or the configuration register location using the MM or MD command.

CAUTION

Caution should be observed when erasing MCU EEPROM locations. EVB MCU configuration (CONFIG) register ROMON bit is cleared to disable MCU internal ROM, thereby allowing external EPROM containing the BUFFALO program to control EVB operations.

EXAMPLE

```
>BULKALL<CR>  
>
```

DESCRIPTION

Bulk erase all MCU EEPROM (\$B600-\$B7FF) and configuration register (\$103F) locations.
Prompt indicates erase sequence completed.

CALL

CALL

4.6.6 Call

```
CALL [<address>]
```

where:

<address> The starting address where user program subroutine execution begins.

The CALL command allows the user to execute a user program subroutine. Execution starts at the current program counter (PC) address location, unless a starting address is specified. Two extra bytes are placed onto the stack before the return from interrupt (RTI) is issued so that the first unmatched return from subroutine (RTS) encountered will return control back to the monitor program. Thus any user program subroutine can be called and executed via the monitor program. Program execution continues until a breakpoint is encountered, or the EVB reset switch S1 is activated (pressed).

Example program for CALL, G, and P command examples

```
>ASM C000<CR>
C000 STX  $FFFF
      >LDAA #44<CR>
      86 44
C002 STX  $FFFF
      >STAA C7FC<CR>
      B7 C7 FC
C005 STX  $FFFF
      >NOP<CR>
      01
C006 STX  $FFFF
      >NOP<CR>
      01
C007 STX  $FFFF
      >NOP<CR>
      01
C008 STX  $FFFF
      >RTS<CR>
      39
C009 STX  $FFFF
      >(CTRL)A
```

CALL**CALL****EXAMPLE****DESCRIPTION**

>CALL C000<CR>

Execute program subroutine.

P-C000 Y-DEFE X-F4FF A-44 B-FE C-D0 S-004A Displays register status at time
> RTS encountered (except
P register contents).

EEMOD

EEPROM Modify Mapping

4.6.7 EEPROM Modify Mapping

```
EEMOD [<address1>] [<address2>]
```

where:

- None Display current starting and ending EEPROM address.
- <address1> Specify new EEPROM starting address.
- <address2> Specify new EEPROM ending address.

The EEMOD command is only used when the EVB resident MCU is changed from XC68HC11A1FN device to an XC68HC11A2FN, XC68HC11E2FN, or XC68HC811E2FN device. The EEMOD command informs the monitor where the EEPROM resident MCU is mapped.

If the starting address is specified and the ending address is not specified, the re-mapped address location will end at <address1> + 2K bytes.

EXAMPLES	DESCRIPTION
<pre>>EEMOD<CR> B600 B7FF ></pre>	<p>Displays current EEPROM starting and ending address locations (XC68HC11A1 device).</p>
<pre>>EEMOD E800<CR> E800 EFFF ></pre>	<p>Specify remapped EEPROM starting address. Starting address & ending address displayed. Ending address automatically established via (<addr1> + 2K bytes).</p>
<pre>>EEMOD F800 FFFF<CR> F800 FFFF ></pre>	<p>Specify remapped EEPROM starting and ending address for an XC68HC811E2 device.</p>

G**Go****4.6.8 Go**

G [<address>]

where:

<address> The starting address where program execution begins.

The G command allows the user to initiate user program execution (free run in real time). The user may optionally specify a starting address where execution is to begin. Execution starts at the current program counter (PC) address location, unless a starting address is specified. Program execution continues until a breakpoint is encountered, or the EVB reset switch S1 is activated (pressed).

NOTE

Refer to example program shown on **page 4-15** and insert breakpoints at locations \$C005 and \$C007 for the following G command example.

EXAMPLE**DESCRIPTION**

>G C000<CR>	Begin program execution at PC address location C000.
P-C005 Y-0000-X-00CD A-44 B-FB C-D0 S-004A	Breakpoint encountered at
>	C005.

HELP
HELP**4.6.9 Help**

HELP

The HELP command enables the user available EVB command information to be displayed on the terminal CRT for quick reference purposes.

EXAMPLE

```
>HELP

ASM [<addr>] Line assembler/disassembler.
/          Do same address.          ^          Do previous address.
CTRL-J    Do next address.          RETURN    Do next opcode.
CTRL-A    Quit.

BF <addr1> <addr2> [<data>] Block fill.
BR [-][<addr>] Set up breakpoint table.
BULK Erase the EEPROM.          BULKALL Erase EEPROM and
CONFIG.
CALL [<addr>] Call user subroutine.          G [<addr>] Execute user
code.
LOAD, VERIFY <T> or <host download command> Load or Verify S-records.
MD [<addr1> [<addr2>]] Memory dump.
MM [<addr>] Memory modify.
/          Open same address.          CTRL-H or ^ Open previous
address.
CTRL-J    Open next address.          SPACE          Open next address.
RETURN    Quit.          <addr>O          Compute Offset to
<addr>.
MOVE <s1> <s2> [<d>] Block move.
P Proceed/continue execution.
RM [P, Y, X, A, B, C, or S] Register modify.
T [<n>] Trace n instructions.
TM Transparent mode (CTRL-A = exit, CTRL-B = send break).
CTRL-H    Backspace.          CTRL-W    Wait for any key.
CTRL-X or DELETE Abort/cancel command.
RETURN Repeat last command.
>
```

LOAD**LOAD****4.6.10 Load**

```
LOAD <host download command><T>
```

where:

<host download command> download S-records to EVB via host port.

<T> download S-records to EVB via terminal port.

The LOAD command moves (downloads) object data in S-record format (see **Appendix A**) from an external host computer to EVB. As the EVB monitor processes only valid S-record data, it is possible for the monitor to hang up during a load operation. If an S-record starting address points to an invalid memory location, the invalid address message "error addr xxxx" is displayed on the terminal CRT (xxxx = invalid address).

EXAMPLES	DESCRIPTION
<pre>>LOAD cat trial.out<CR> cat trial.out done ></pre>	LOAD command entered to download data from host computer to EVB via host port.
<pre>>LOAD cat trial.out<CR> cat trial.out error addr E000 ></pre>	LOAD command entered. Invalid address message. S-records must be downloaded into RAM.

Refer to the downloading procedures at the end of this chapter for additional information pertaining to the use of the LOAD command.

MD

Memory Display

4.6.11 Memory Display

```
MD [<address1> [<address2>]]
```

where:

<address1> Memory starting address (optional).
 [<address2>] Memory ending address (optional).

The MD command allows the user to display a block of user memory beginning at address1 and continuing to address2. If address2 is not entered, 9 lines of 16 bytes are displayed beginning at address1. If address1 is greater than address2, the display will default to the first address. If no addresses are specified, 9 lines of 16 bytes are displayed near the last memory location accessed.

EXAMPLES

```
>MD E61F<CR>
```

```
E61F    42 55 46 46 41 4C 4F 20 33 2E 32 20 28 69 6E 74 29 20 2D 20 42 69 74 20 55
       73 65 72 20 46 61 73 74 20 46 72 69 65 6E 64 6C 79 20 41 69 64 20 74 6F 20
       4C 6F 67 69 63 61 6C 20 4F 70 65 72 61
```

```
>
```

```
>MD C030 C020<CR>
```

```
C030    FF FF FF FF FF FF FF FF FF FF FF FF FF FF FF
```

```
>
```

```
>MD C000 C020<CR>
```

```
C000    86 04 B7 01 FC 01 01 01 39 FF FF FF FF FF FF FF
C010    FF FF FF FF FF FF FF FF FF FF FF FF FF FF
C020    FF FF FF FF FF FF FF FF FF FF FF FF FF FF
```

```
>
```

9

MM**Memory Modify****4.6.12 Memory Modify**

MM [<address>]

where:

<address> is the memory location at which to start display/modify.

CAUTION

Caution should be observed when modifying EEPROM locations. EVB MCU CONFIG register ROMON bit is cleared to disable MCU internal ROM.

The MM command allows the user to examine/modify contents in user memory at specified locations in an interactive manner. The MM command will also erase any EEPROM location, and will reprogram the location with the corresponding value (EEPROM locations treated as if RAM).

Once entered, the MM command has several sub-modes of operation that allow modification and verification of data. The following subcommands are recognized.

(CTRL)J or (SPACE BAR) or +	Examine/modify next location.
(CTRL)H or ^ or -	Examine/modify previous location.
/	Examine/modify same location.
<CR>	Terminate MM operation.
O	Compute branch instruction relative offset.

If an invalid address is specified, the invalid address message "rom" is displayed on the terminal CRT.

MM**Memory Modify****CAUTION**

Caution should be observed when modifying EEPROM locations. EVB MCU CONFIG register ROMON bit is cleared to disable MCU internal ROM.

EXAMPLES**DESCRIPTION**

>MM C700<CR>	Display memory location C700.
C700 44 66/<CR>	Change data at C700 and reexamine location.
C700 66 55 ^	Change data at C700 and backup one location.
C6FF FF AA<CR>	Change data at C6FF and terminate MM operation.
>MM C13C<CR>	Display memory location.
C13C F7 C18EO 51<CR>	Compute offset, result = \$51.
C13C F7	
>MM C000<CR>	Examine location \$C000.
C000 55 80 C2 00 CE C4	Examine next location(s) using (SPACE BAR).
>MM B600<CR>	Examine EEPROM location \$B600.
B600 73 52<CR>	Change data at location \$B600.
>MM B600<CR>	Reexamine EEPROM location \$B600.
B600 52	
>	

MOVE**MOVE****4.6.13 Move**

```
MOVE <address1> <address2> [<dest>]
```

where:

<address1>	Memory starting address.
<address2>	Memory ending address.
[<dest>]	Destination starting address (optional).

The MOVE command allows the user to copy/move memory to new memory location. If the destination is not specified, the block of data residing from address1 to address2 will be moved up one byte. Using the MOVE command on EEPROM locations will program EEPROM cells.

The MOVE command is useful when programming EEPROM. As an example, a program is created in user RAM using the assembler, debugged using the monitor, and then programmed into EEPROM with the MOVE command.

No messages will be displayed on the terminal CRT upon completion of the copy/move operation, only the prompt is displayed.

CAUTION

Caution should be observed when moving data into EEPROM locations. EVB MCU CONFIG register ROMON bit is cleared to disable MCU internal ROM.

EXAMPLE

```
>MOVE E000 E7FF C000<CR>  
>
```

DESCRIPTION

Move data from locations \$E000-\$E7FF to locations \$C000-\$C7FF.

P**Proceed****4.6.14 Proceed/Continue**

P

This command is used to proceed or continue program execution without having to remove assigned breakpoints. This command is used to bypass assigned breakpoints in a program executed by the G command.

NOTE

Refer to example program shown on **page 4-15** for the following P command example. Breakpoints have been inserted at locations \$C005 and \$C007 (refer to example on **page 4-17**).

EXAMPLE	DESCRIPTION
>G C000<CR>	Start execution at C000.
P-C005 Y-7982 X-FF00 A-44 B-70 C-D0 S-004A	Breakpoint encountered at C005.
>P<CR>	Continue execution.
P-C007 Y-7982 X-FF00 A-44 B-70 C-C0 S-004A	Breakpoint encountered at C007.
>	

RM**Register Modify****4.6.15 Register Modify**

RM [p, y, x, a, b, c, s]

The RM command is used to modify the MCU program counter (P), Y index (Y), X index (X), A accumulator (A), B accumulator (B), C accumulator (C), and stack pointer (S) register contents.

EXAMPLES	DESCRIPTION
<pre>>RM<CR> P-C007 Y-7982 X-FF00 A-44 B-70 C-C0 S-0054 P-C007 C020<CR></pre>	<p>Display P register contents.</p> <p>Modify P register contents.</p>
<pre>></pre>	
<pre>>RM X<CR> P-C007 Y-7982 X-FF00 A-44 B-70 C-C0 S-0054 X-FF00 C020<CR></pre>	<p>Display X register contents.</p> <p>Modify X register contents.</p>
<pre>></pre>	
<pre>>RM<CR> P-C020 Y-DEFE X-C020 A-DF B-DE C-D0 S-0054 P-C020 (SPACE BAR) Y-DEFE (SPACE BAR) X-C020 (SPACE BAR) A-DF (SPACE BAR) B-DE (SPACE BAR) C-D0 (SPACE BAR) S-0054 (SPACE BAR)</pre>	<p>Display P register contents.</p> <p>Display remaining registers.</p> <p>(SPACE BAR) entered following stack pointer display terminates RM command.</p>
<pre>></pre>	

STOPAT

Stop at Address

4.6.16 Stop at Address

```
STOPAT <address>
```

where:

<address> The specified user program counter (PC) stop address.

The STOPAT command causes a user program to be executed one instruction at time until the specified address is encountered. Execution begins with the current user PC address and stop just before execution of the instruction at the specified stop address. The STOPAT command should only be used when the current value of the user PC register is known. For example after a breakpoint is reached or after an RD command is used to set the user PC.

The STOPAT command has an advantage over breakpoints in that a stop address can be a ROM location while breakpoints only operate in RAM or EEPROM locations. Since the STOPAT command traces one instruction at a time with a hidden return to the monitor after each user instruction, some user programs will appear to execute slowly.

The stop address specified in the STOPAT command must be the address of an opcode just as breakpoints can only be set at opcode addresses.

NOTE

Refer to example program shown on **page 4-15** for the following STOPAT command example. The RD command was used prior to this example to set the user PC register to \$C000.

EXAMPLE

```
>STOPAT 0108<CR>
P-0108 Y-DEFE X-F4FF A-04 B-FE C-90 S-0047
>
```

DESCRIPTION

Execute example program until \$0108 is reached.

T**Trace****4.6.17 Trace**

T [<n>]

where:

<n> The number (in hexadecimal, \$1-FF max.) of instructions to execute.

The T command allows the user to monitor program execution on an instruction-by-instruction basis. The user may optionally execute several instructions at a time by entering a count value (up to \$FF). Execution starts at the current program counter (PC). The PC displayed with the event message is of the next instruction to be executed. The trace command operates by setting the OC5 interrupt to time out after the first cycle of the first opcode fetched.

NOTE

The RD command was used to set the user PC register to \$FF85 prior to starting the following trace examples.

SINGLE TRACE EXAMPLE

```
>T<CR>
JMP  $E1F7                P-E1F7 Y-FFFF X-FFFF A-04 B-FF C-10 S-0046
>
```

MULTIPLE TRACE EXAMPLES

```
>T 2<CR>
PSHA                P-E1F8 Y-FFFF X-FFFF A-04 B-FF C-10 S-0046
PSHB                P-E1F9 Y-FFFF X-FFFF A-04 B-FF C-10 S-0045
>T 3<CR>
PSHX                P-E1FA Y-FFFF X-FFFF A-04 B-FF C-10 S-0043
JSR  $E19D          P-E19D Y-FFFF X-FFFF A-04 B-FF C-10 S-0041
CMPA  #$61          P-E19F Y-FFFF X-FFFF A-04 B-FF C-19 S-0041
>T 4<CR>
BLT  $E1A7          P-E1A7 Y-FFFF X-FFFF A-04 B-FF C-19 S-0041
RTS                P-E1FD Y-FFFF X-FFFF A-04 B-FF C-19 S-0043
CMPA  #$30          P-E1FF Y-FFFF X-FFFF A-04 B-FF C-19 S-0043
BLT  $E223          P-E223 Y-FFFF X-FFFF A-04 B-FF C-19 S-0043
>
```

TM**Transparent Mode****4.6.18 Transparent Mode**

TM

The TM command connects the EVB host port to the terminal port, which allows direct communication between the terminal and the host computer. All I/O between the ports are ignored by the EVB until the exit character is entered from the terminal.

The TM subcommands are as follows:

(CTRL)A Exit from transparent mode.
 (CTRL)B Send break to host computer.

EXAMPLE	DESCRIPTION
> TM <CR>	Enter transparent mode.
appslab login: ED <CR> Password:XXXX<CR>	Host computer login response. XXXX = host computer password.
"System Message"	
\$. . . \$ (CTRL)A >	Task completed. Enter exit command. Exit transparent mode.

Refer to the downloading procedures at the end of this chapter for additional information pertaining to the use of the TM command.

VERF**Verify****4.6.19 Verify**

```
VERIFY <host download command><T>
```

where:

- <host download command> Compare memory to host port download data.
- <T> compare memory to terminal port download data.

The VERIFY command is similar to the LOAD command except that the VERIFY command instructs the EVB to compare the downloaded S-record data to the data stored in memory.

EXAMPLES	DESCRIPTION
<pre>>VERIFY cat trial.out<CR> cat trial.out done ></pre>	<pre>Enter verify command. Verification completed.</pre>
<pre>>VERIFY cat trial.out<CR> cat trial.out</pre>	<pre>Enter verify command. Mismatch encountered.</pre>
<pre>error addr E000 ></pre>	<pre>Error message displaying first byte address.</pre>

Refer to the downloading procedures at the end of this chapter for additional information pertaining to the use of the LOAD command.

XBOOT

Transfer Data Bootstrap Mode

4.6.20 Transfer Data Bootstrap Mode

```
XBOOT [<address1> [<address2>]]
```

where:

- <address1> Starting address.
- <address2> Ending address.

The XBOOT command loads/transfers a block of data from address1 through address2 via the serial communications interface (SCI) to another MC68HC11 MCU device which has been reset in the bootstrap mode. A leading control character of \$FF is sent prior to sending the data block. This control character is part of the bootstrap mode protocol and establishes the baud rate for the rest of the transfer.

If only one address is provided, the address will be used as the starting address and the block size will default to 256 bytes. If no addresses are provided, the block of addresses from \$C000 through \$C0FF is assumed by the BUFFALO monitor program.

NOTE

The MC68HC11A8 MCU requires a fixed block size of 256 bytes for bootloading while the MC68HC11E9 MCU can accept a variable length block of 1 to 512 bytes.

The XBOOT command generates SCI transmitter output signals at 7812.5 baud which are intended for another MC68HC11 MCU device operating in the bootstrap mode. These signals appear as nonsense data to the terminal display used for normal communication with the EVB. After using the XBOOT command the EVB must be reset by pressing the reset switch S1 before normal communications can resume.

XBOOT

Transfer Data Bootstrap Mode

The following procedure describes the use of the XBOOT command:

1. Assemble or fill EVB MCU EEPROM (locations \$B600-\$B6FF) with program to be bootloaded (transmitted/transferred) to target MC68HC11 MCU device.
2. Enter XBOOT command and addresses without pressing carriage return <CR> key as follows:

>XBOOT B600 B6FF (Do not press the RETURN key.)

3. Remove previously installed fabricated jumper from jumper header J6.
4. Connect jumper wire from jumper header J6 pin 1 to RxD input of target MC68HC11 MCU device.
5. Reset target MC68HC11 MCU device in bootstrap mode.
6. Press carriage return <CR> key to invoke XBOOT command.

Since TxD is not connected to the terminal, the user will not observe any changes on the terminal display CRT. The bootload process takes approximately a third of a second to finish.

7. Disconnect jumper wire installed in step d.
8. Install fabricated jumper removed in step c.
9. Press EVBU reset switch S1 to restore normal EVB operation.

4.7 ASSEMBLY/DISASSEMBLY PROCEDURES

The assembler/disassembler is an interactive assembler/editor. Each source line is converted into the proper machine language code and is stored in memory overwriting previous data on a line-by-line basis at the time of entry. In order to display an instruction, the machine code is disassembled and the instruction mnemonic and operands are displayed. All valid opcodes are converted to assembly language mnemonics. All invalid opcodes are displayed on the terminal CRT as "ILLOP".

The syntax rules for the assembler are as follows: (a.) All numerical values are assumed to be hexadecimal. Therefore no base designators (e.g., \$ = hex, % = binary, etc.) are allowed. (b.) Operands must be separated by one or more space or tab characters. (c.) Any characters after a valid mnemonic and associated operands are assumed to be comments and are ignored.

Addressing modes are designated as follows: (a.) Immediate addressing is designated by preceding the address with a # sign. (b.) Indexed addressing is designated by a comma. The comma must be preceded a one byte relative offset (even if the offset is 00), and the comma must be followed by an X or Y designating which index register to use (e.g., LDAA 00,X). (c.) Direct and extended addressing is specified by the length of the address operand (1 or 2 digits specifies direct, 3 or 4 digits specifies extended). Extended addressing can be forced by padding the address operand with leading zeros. (d.) Relative offsets for branch instructions are computed by the assembler. Therefore the valid operand for any branch instruction is the branch-if-true address, not the relative offset.

Assembler/disassembler subcommands are as follows. If the assembler directs an error in the new source line, the assembler will output an error message and then reopen the same address location.

- / Assemble the current line and then disassemble the same address location.
- ^ Assemble the current line and then disassemble the previous sequential address location.
- <CR> Assemble the current line and then disassemble the next opcode address.
- (CTRL)J Assemble the current line. If there isn't a new line to assemble, then disassemble the next sequential address location. Otherwise, disassemble the next opcode address.
- (CTRL)A Exit the assembler mode of operation.

When a new source line is assembled, the assembler overwrites what was previously in memory. If no new source line is submitted, or if there is an error in the source line, then the contents of memory remain unchanged. Each of the instruction pairs Arithmetic Shift Left (ASL)/Logical Shift Left (LSL) have the same opcode, so disassembly always displays the ASL mnemonic. If the assembler tries to assemble at an address that is not in RAM, an invalid address message "rom-xxxx" is displayed on the terminal CRT (xxxx = invalid address).

The following pages describe how to operate the assembler/disassembler by creating a typical program loop, and debugging the program by the use of the EVB monitor commands. A typical Serial Communications Interface (SCI) program loop is first assembled. Routine examples are then provided to illustrate how to perform breakpoint setting, proceeding from breakpoint, register display and modification, and initiation of user program execution.

A program loop (that transmits RAM data from the SCI transmitter to the SCI receiver) is assembled as follows:

EXAMPLE PROGRAM**PROGRAM DESCRIPTION**

>BF C200 C21F 00<CR>	Clear memory space.
>ASM C000	Enter assembler/disassembler mode.
C000 CLR \$0800 18 CE C2 00	>LDY #C200<CR> First byte where data is stored.
C004 TEST CE C4 00	>LDX #C400<CR> Point to data to be fetched.
C007 TEST B6 10 2E	>LDAA 102E<CR> Clear RDRF bit if set.
C00A TEST A6 00	>LDAA 0,X<CR> Get first data byte.
C00C TEST B7 10 2F	>STAA 102F<CR> Store data in SCI data register.
C00F INX B6 10 2E	>LDAA 102E<CR> Read SCI status register.
C012 TEST 84 80	>ANDA #80<CR> Send data byte.
C014 TEST 27 F9	>BEQ C00F<CR> Wait for empty transmit data reg.
C016 BITB \$80F6 B6 10 2E	>LDAA 102E<CR> Read SCI status register.
C019 BVS \$C01B 84 20	>ANDA #20<CR> Extract RDRF bit from status reg.

(continued)

EXAMPLE PROGRAM**PROGRAM DESCRIPTION**

C01B	STX \$00FF 27 F9	>BEQ C016<CR>	Branch true = SCI RDR not full. Branch false = SCI RDR full.
C01D	STX \$4D65 B6 10 2F	>LDAA 102F<CR>	Read data from SCI RDR.
C020	STAA \$00,Y 18 A7 00	>STAA 0,Y<CR>	Store data byte.
C023	STX \$00FF 08	>INX<CR>	Increment fetch pointer.
C024	TEST 18 08	>INY<CR>	Increment storage pointer.
C026	ASRB 8C C4 1F	>CPX #C41F<CR>	Done sending data?
C029	ASLD 27 03	>BEQ C02E<CR>	
C02B	STX \$00FF 7E C0 0C	>JMP C00C<CR>	No, get next data byte.
C02E	MUL 20 FE	>BRA C02E<CR>	Yes, stop here.
C030	ILLOP	>(CTRL)A	Exit assembler/disassembler mode.
	>		

The routines, on the next page, are performed on the SCI program loop just assembled:

NOTE

Connector P1 pins 20 and 21 are connected (connects SCI transmitter to the receiver) in order to perform the following routines.

TERMINAL CRT/KEYBOARD
ROUTINE DESCRIPTION

```

>RM                                     Display user machine state.
P-C000 Y-E8CC X-6FD1 A-DF B-0F C-D0 S-0054
P-C000 C000
Y-E8CC (SPACE BAR)
X-6FD1 (SPACE BAR)
A-DF (SPACE BAR)
B-0F (SPACE BAR)
C-D0 FF
>BF C400 C41F 55<CR>                   Block fill with $55.

>MD C400 C41F<CR>                       Verify block fill.

C400 55 55 55 55 55 55 55 55 55 55 55 55 55 55 UUUUUUUUUUUUUUUUUUU
C410 55 55 55 55 55 55 55 55 55 55 55 55 55 55 UUUUUUUUUUUUUUUUUUU
>BF C200 C220 00<CR>                   Clear data storage area.

>BR C004 C00A C02E<CR>                 Set breakpoints.

C004 C00A C02E 0000
>G C000<CR>                             Execute program.

P-C004 Y-C200 X-6FD1 A-DF B-0F C-F9 S-004A
>P<CR>                                   Proceed thru first breakpoint.

P-C00A Y-C200 X-C400 A-C0 B-0F C-E9 S-004A
>BR C024<CR>                             Insert breakpoint.

C004 C00A C02E C024
>P<CR>

P-C024 Y-C200 X-C401 A-55 B-0F C-E1 S-004A

>MD C200 C210<CR>                       Display machine state after first loop.
C200 55 00 00 00 00 00 00 00 00 00 00 00 00 00 00 U
C210 00 00 00 00 00 00 00 00 00 00 00 00 00 00 00
>P

P-C024 Y-C201 X-C402 A-55 B-0F C-E1 S-004A
>MD C200 C210<CR>                       Display machine state after second loop.
C200 55 55 00 00 00 00 00 00 00 00 00 00 00 00 00 UU
C210 00 00 00 00 00 00 00 00 00 00 00 00 00 00 00
>BR -C024<CR>                           Remove breakpoint.

C004 C00A C02E 0000

```

(continued)

4.8 DOWNLOADING PROCEDURES

This portion of text describes the EVB downloading procedures. The downloading operation enables the user to transfer information from Motorola's EXORciser development station or a host (personal) computer to the EVB (or target system memory). Specific downloading procedures are described enabling the user to perform downloading operations with an EXORciser development station and host personal computer (PC) systems.

EXORciser downloading operations are accomplished utilizing the TM and LOAD commands. The TM (Transparent Mode) command connects the EVB host port to the terminal port, which allows direct communication between the terminal and host computer. All I/O between the ports are ignored by the EVB until the exit command (CTRL)A is entered from the terminal. The LOAD command moves data information in S-record format (see **Appendix A**) from an external host computer to the EVB user RAM. The VERIFY command is used to compare the S-record data to memory data.

Ensure that a jumper is installed on pins 1 and 2 of the host port RX signal disabling header J4 during all downloading operations or when communicating to a host computer (e.g., EXORciser) in the transparent mode. (Refer to **paragraph 2.3.6.**) The transparent mode of operation is not applicable to the PC to EVB operations. Therefore the TM command is not utilized in the PC (e.g., Apple Macintosh and IBM-PC) downloading procedures.

The following pages provide examples and descriptions of how to perform EVB downloading operations in conjunction with an EXORciser development station, and Apple Macintosh and IBM-PC host computer systems.

Downloading operations allow Motorola's S-record files to be transferred from a host computer to the EVB or to be verified against data in EVB memory. S-record files are made up of data and checksum values in a special format which facilitates downloading.

A software terminal emulator program is required for PC downloading S-record files. Some typical terminal emulator programs for the IBM-PC include PROCOMM and KERMIT. Typical terminal emulator programs for the Apple Macintosh include MacTerminal and Red Ryder.

S-record programs for downloading are created by assembling programs on the PC. The steps needed to develop a program are described briefly as follows:

1. Assembly language program is entered into a text file on the PC. A text editor is used to create this text file which is called a source program.
2. An assembler program operating on the PC is used to translate the source program into an S-record object file and/or listing file. Buf25.asm file on the EVB diskette is an example of a large listing.
3. After the creation of the S-record files, the files are downloaded to the EVB as shown in the following step-by-step procedures.

4.8.1 EXORciser to EVB

To perform the EXORciser to EVB downloading procedure, perform/observe the following:

EXAMPLES	DESCRIPTION
<pre>>TM <CR> <CR> EXBUG09 2.1 *E MDOS <CR> MDOS09 3.05 =(CTRL)A >LOAD COPY TRIAL.LX:1,#CN<CR></pre>	<p>EXORciser initialized into MDOS via TM command to download S-records.</p> <p>Exit transparent mode.</p> <p>LOAD command entered to download data to EVB through host port.</p>
<pre>>LOAD COPY TRIAL.LX:1,#CN<CR> COPY TRIAL.LX:1,#CN done ></pre>	<p>LOAD command entered.</p> <p>Downloading successful.</p> <p>Data transfer completed.</p>
<pre>>LOAD COPY TRIAL.LX:1,#CN<CR> COPY TRIAL.LX:1,#CN error addr F800 ></pre>	<p>LOAD command entered.</p> <p>Downloading unsuccessful.</p> <p>Error address displayed.</p>
<pre>>VERIFY COPY TRIAL.LX:1,#CN<CR> COPY TRIAL.LX:1,#CN done ></pre>	<p>VERIFY command entered.</p> <p>Compares S-records to RAM file.</p> <p>Comparison verified.</p>
<pre>>VERIFY COPY TRIAL.LX:1,#CN<CR> COPY TRIAL.LX:1,#CN error addr F800 ></pre>	<p>VERIFY command entered.</p> <p>Verification unsuccessful.</p> <p>Error address displayed.</p>

4.8.2 Apple Macintosh (with MacTerminal) to EVB

The MacTerminal downloading program in this application is used as a terminal emulator for the Apple Macintosh computer. To download a Motorola S-record file from the Apple Macintosh computer to the EVB, perform the following steps:

1. Select the following menu Terminal Settings:

Terminal:	TTY
Cursor Shape:	Underline
Line Width:	80 Columns
Select:	On Line Auto Repeat
Click on:	OK

2. Select the following menu Compatibility Settings:

Baud rate:	9600 (same as EVBU)
Bits per Character:	8 Bits
Parity:	None
Handshake:	None
Connection:	Modem or Another Computer
Connection Port:	Modem or Printer
Click on:	OK

3. Select the following menu File Transfer Settings:

Settings for Pasting or Sending Text:	Word Wrap Outgoing Text
File Transfer Protocol:	Text
Settings for Saving Lines Off Top:	Retain Line Breaks
Click on:	OK

4. Apply power to the EVB.
5. Press Apple Macintosh computer keyboard carriage return <CR> key to display applicable EVB monitor prompt.
6. Apple Macintosh computer displays the > prompt.

-
7. Enter EVB monitor download command as follows:
 >**LOAD T** (Press RETURN after entering LOAD T.)
 8. Operate pull-down File menu, and select (choose): Send File ...
 9. Use dialog box and select applicable S-record object file.
 Click on: Send
- Motorola S-record file is now transferred to the EVB.

NOTE

S-record file will not be displayed during the file transfer to the EVB.

Upon completion of the S-record transfer, the following message is displayed:

```
done
>
```

NOTE

The EVB may have to be reset to regain monitor control depending on the version of BUFFALO and how the file transfer program terminates the download operation.

There is a problem which occurs when using the EVB with the MacTerminal program when performing a downloading operation. The MacTerminal program sends a carriage return and line feed characters at the end of the downloaded S-record file. The EVB monitor treats this as an erroneous command; you must RESET the EVB to regain control of the monitor.

4.8.3 Apple Macintosh (with Red Ryder) to EVB

The Red Ryder downloading program in this application is also used as a terminal emulator for the Apple Macintosh computer. To download a Motorola S-record file from the Apple Macintosh computer to the EVB, perform the following steps:

1. Launch Red Ryder program.
2. Set up computer program to match EVB baud rate (typically) as follows:
9600 baud, no parity, 8-bits, 1-stop bit, full duplex
3. Apply power to EVB.
4. Press Apple Macintosh computer keyboard carriage return <CR> key to display applicable EVB monitor prompt.
5. Enter EVB monitor download command as follows:
>**LOAD T** (Press RETURN after entering LOAD T.)
6. Operate pull-down File menu, and select (choose):
Send File - ASCII...
7. Use dialog box and select applicable S-record object file.
Click on: Send
Motorola S-record file is now transferred to the EVB.

NOTE

S-record file will not be displayed during the file transfer to the EVB.

Upon completion of the S-record transfer, the following message is displayed:

```
done  
>
```

4.8.4 IBM-PC (with KERMIT) to EVB

Prior to performing any IBM-PC operation, ensure that both IBM-PC and EVB baud rates are identical, and that the IBM-PC asynchronous port is configured for terminal mode of operation. If the asynchronous port is hard wired for host mode of operation and cannot be reconfigured for a terminal mode of operation, the use a null modem (transmit (TxD) and receive (RxD) and associated handshake lines are cross coupled) is required.

NOTE

IBM-PC to EVB interconnection is accomplished by one RS-232C cable assembly. This cable is connected to the EVB terminal I/O port connector P2 for downloading operations.

To perform the IBM-PC to EVB downloading procedure, perform/observe the following:

EXAMPLE	DESCRIPTION
C> KERMIT <CR> IBM-PC Kermit-MS VX.XX Type ? for help	IBM-PC prompt. Enter Kermit program.
Kermit-MS> SET BAUD 9600 <CR> Kermit-MS> CONNECT <CR>	Set IBM-PC baud rate. Connect IBM-PC to EVB.
[Connecting to host, type Control-] C to return to PC]	
<CR> > LOAD T <CR>	EVB download command (via terminal port) entered.
(CTRL)C Kermit-MS> PUSH <CR>	
The IBM Personal Computer DOS Version X.XX (C)Copyright IBM Corp 1981, 1982, 1983	
C> TYPE (File Name) > COM1 <CR>	Motorola S-record file name.
C> EXIT <CR>	S-record downloading completed.
Kermit-MS> CONNECT <CR>	Return to EVB monitor program.
>(CTRL)C Kermit-MS> EXIT <CR>	Exit Kermit program.

4.8.5 IBM-PC (with PROCOMM) to EVB

To perform the IBM-PC to EVB downloading procedure with PROCOMM, perform/observe the following:

1. Invoke the PROCOMM.EXE program.
2. Setup PROCOMM to match EVB baud rate and protocol (type **(Alt)S**, then the number **2**) as follows:
 - 9600 baud, no parity, 8-bits, 1-stop bit, full duplex
3. Setup ASCII transfer parameters (type **(Alt)S**, then the number **6**) as follows:
 - Echo Local - Yes
 - Expand Blank Lines - Yes
 - Pace Character - 0
 - Character pacing - 25 (1/1000 second)
 - Line Pacing - 10
 - CR Translation - None
 - LF Translation - None
 - Save above settings to disk for future use.
4. Apply power to EVB.
5. Press IBM-PC keyboard carriage return <CR> key to display applicable EVB monitor prompt.
6. Enter EVB monitor download command as:
 - >**LOAD T** (Press RETURN after entering LOAD T.)
7. Instruct PROCOMM to send the S-record file by pressing the Pg Up key on the PC, then follow PROCOMM instructions on the display screen to select the S-record file.
Motorola S-record file is now transferred to the EVB.
Upon completion of the S-record transfer, the following message is displayed:

done

>



CHAPTER 5

HARDWARE DESCRIPTION

5.1 INTRODUCTION

This chapter provides an overall general description of the EVB hardware. This description is supported by a simplified block diagram (Figure 5-1) and a memory map diagram (Figure 5-2). The EVB schematic diagram, located in Chapter 6, can also be referred to for the following descriptions.

5.2 GENERAL DESCRIPTION

Overall evaluation/debugging control of the EVB is provided by the monitor BUFFALO program residing in EPROM (external to the MCU) via terminal intervention. The target system interface is provided by the MCU and PRU devices. RS-232C terminal/host I/O port interface circuitry provides communication and data transfer operations between the EVB and external terminal/host computer devices.

5.2.1 Microcomputer

The M68HC11A1 MCU (U10) operates in the expanded mode of operation. This is accomplished by +5 Vdc applied to the MCU MODA and MODB pins. The MCU configuration (CONFIG) register (implemented in EEPROM) is programmed such that the ROMON bit is cleared for EVB operations. When this bit is cleared, MCU internal ROM is disabled, and that memory space becomes externally accessed space. This allows the memory at \$E000-\$FFFF to contain the monitor BUFFALO program (or user program for emulation) in external EPROM.

The monitor program uses the MCU internal RAM located at \$0048-\$00FF. The control registers are located at \$1000-\$103F.

The EVB allows the user to use all the features of the monitor BUFFALO program, however it should be noted that the monitor program uses the MCU on-chip RAM locations \$0048-\$00FF leaving only 72 bytes for the user (i.e., \$0000-\$0047). This should be remembered when writing code.

5.2.2 Port Replacement Unit

The EVB operates in the expanded multiplexed mode of operation. An MC68HC24 PRU device (U1) is used to replace the MCU I/O ports B and C (including STRA and STRB control lines) used for single chip mode of operation. The PRU provides the required single chip mode I/O lines for target system evaluation (emulation) via the EVB MCU extension I/O port connector P1.

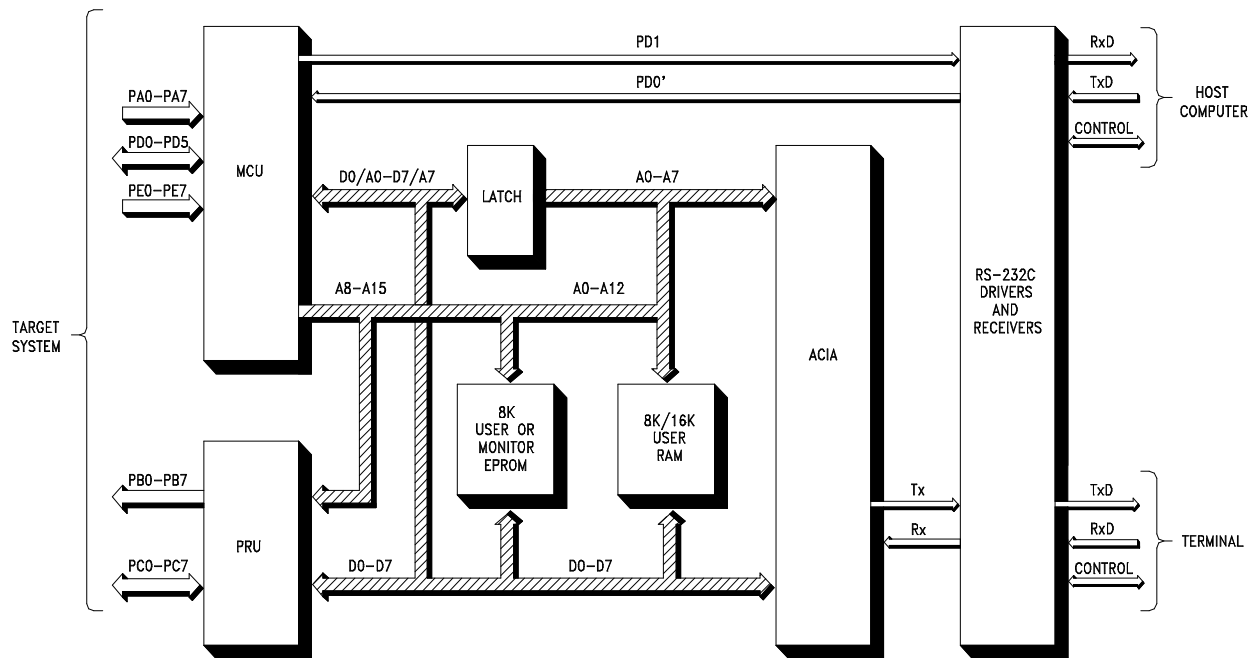

Figure 5-1. EVB Block Diagram

INTERNAL RAM (MCU RESERVED)	\$0000 \$00FF
NOT USED	\$0100 \$0FFF
PRU+REG.DECODE	\$1000 \$17FF
NOT USED	\$1800 \$3FFF
FLIP-FLOP DECODE	\$4000 \$5FFF
OPTIONAL 8K RAM	\$6000 \$7FFF
NOT USED	\$8000 \$97FF
TERMINAL ACIA	\$9800 \$9FFF
NOT USED	\$A000 \$B5FF
EEPROM	\$B600 \$B7FF
NOT USED	\$B800 \$BFFF
USER RAM	\$C000 \$DFFF
MONITOR EPROM	\$E000 \$FFFF

\$0000-\$0032 USER RAM
 \$0033-\$0047 USER STACK POINTER
 \$0048-\$00C3 MONITOR VARIABLES
 \$00C4-\$00FF VECTOR JUMP TABLE

Figure 5-2. EVB Memory Map Diagram

5.2.3 Memory

The EVB memory map is a single map design. User RAM resides at different address locations to that of the MCU ROM. Any code debugged in the RAM which is not re-locatable will require modification before being transferred to EPROM and executed instead of the monitor (evaluation mode).

To evaluate programs normally held in ROM, an 8k byte RAM is provided (socket U5). An access time of 250 nanoseconds is necessary for a bus frequency of 2.1 MHz. Jumper headers J3 and J7 configure socket U4 for an additional 8k byte RAM supplied by the user if required. Refer to paragraph 2.3.3 for additional memory select information.

5.2.4 Address Decoding/De-multiplexing

Address decoding is accomplished via a MC74HC138 device (U6) and is segmented into 8k byte blocks. The low order address and data lines are de-multiplexed using a MC74HC373 device (U2), to communicate with ROM, RAM, and the ACIA. The PRU uses a multiplexed input direct from the MCU.

5.2.5 RS-232C I/O Port Interface Circuits

The EVB uses an MC68B50 ACIA device (U9) to communicate to a terminal via an RS-232C driver/receiver interface (terminal I/O port). The terminal I/O port baud rate is hardware selectable (300-9600 baud) via jumper header J5.

A second RS-232C driver/receiver interface (host I/O port) is fixed at 9600 baud via the MCU SCI using a 2 MHz E clock external bus. This baud rate can be changed by software by reprogramming the BAUD register in the ONSCI subroutine of the BUFFALO monitor program. Refer to the buf25.asm file on the EVB diskette for additional information pertaining to the ONSCI subroutine.

The host I/O port is provided for downloading Motorola S-records via the BUFFALO monitor commands. When using the host I/O port, either by executing the HOST or LOAD commands, The target system Serial Communications Interface (SCI) is switched to the host I/O port via the MC74HC4066 digital switch device (U7) and MC74HC74 latch device (U11). The receiver connection from the host I/O port is now connected to the RXD port of the MCU. The switching of the receiver line from the target system to the host I/O port is accomplished by writing a logic one in the bit 0 to any address in the range \$4000-\$5FFF. Likewise, writing a zero in bit 0 to any address in the same range results in the target system being connected to the RXD pin of the MCU.

As the RS-232C handshake lines are not used, a delay of approximately 300 milliseconds is present between successive characters sent to the host computer during the execution of the LOAD command in the monitor program.

CHAPTER 6

SUPPORT INFORMATION

6.1 INTRODUCTION

This chapter provides the connector signal descriptions, parts list with associated parts location diagram, and schematic diagrams for the EVB.

6.2 CONNECTOR SIGNAL DESCRIPTIONS

The EVB provides one input/output (I/O) connector that is used to interconnect the EVB to a target system. Connector P1 facilitates this interconnection.

Connectors P2 and P3 are also provided to facilitate interconnection of a terminal and a host computer, respectively. Connector P4 interconnects an external power supply to the EVB.

Pin assignments for the above connectors (P1 through P4) are identified in Tables 6-1 through 6-4, respectively. Connector signals are identified by pin number, signal mnemonic, and signal name and description.

Table 6-1. MCU I/O Port Connector (P1) Pin Assignments

Pin Number	Signal Mnemonic	Signal Name and Description
1	GND	Ground
2	MODB	MODE B - An input control line used for MCU mode selection. A high level enables the expanded multiplexed mode, and a low level enables the special test mode of the EVB MCU.
3	MODA	MODE A - An input control line used for MCU mode selection during reset. An open-drain output line used for LIR* status indication.
4	STRA	STROBE A - An input control line used for parallel port I/O operations.
5	E	ENABLE CLOCK - An output control line used for timing reference. E clock frequency is one fourth the frequency of the XTAL and EXTAL pins.
6	STRB	STROBE B - An output control line used for parallel port I/O operations.
7	EXTAL	EXTAL - External MCU clock input line.
8	XTAL	XTAL - Internal MCU clock line used to control the EVB clock generator circuitry.
9-16	PC0-PC7	PORT C (bits 0-7) - General purpose I/O lines.
17	RESET*	RESET - An active low bi-directional control line used to initialize the MCU.
18	XIRQ*	X INTERRUPT REQUEST - An active low input line used to request asynchronous non-maskable interrupts to the MCU.

Table 6-1. MCU I/O Port Connector (P1) Pin Assignments (continued)

Pin Number	Signal Mnemonic	Signal Name and Description
19	IRQ*	INTERRUPT REQUEST – An active low input line used to request asynchronous interrupts to the MCU.
20 21 22 23 24 25	PD0 PD1 PD2 PD3 PD4 PD5	PORT D (bits 0-5) – General purpose I/O lines. These lines can be used with the MCU Serial Communications Interface(SCI) and Serial Peripheral Interface(SPI).
26	VDD	VDD – +5.0 Vdc power.
27-34	PA7-PA0	PORT A (bits 7-0) – General purpose I/O lines.
35-42	PB7-PB0	PORT B (bits 7-0) – General purpose output lines.
43 44 45 46 47 48 49 50	PE0 PE4 PE1 PE5 PE2 PE6 PE3 PE7	PORT E (bits 0-7) – General purpose input or A/D channel input lines.
51	VRL	VOLTAGE REFERENCE LOW - Input reference supply voltage (low) line for the MCU analog-to-digital (A/D) converter. Used to increase accuracy of the A/D conversion.
52	VRH	VOLTAGE REFERENCE HIGH - Input reference supply voltage (high) line. Same purpose as pin 51.
53-60	NC	Not connected.

Table 6-2. Terminal I/O Port Connector (P2) Pin Assignments

Pin Number	Signal Mnemonic	Signal Name and Description
1	GND	PROTECTIVE GROUND
2	RXD	RECEIVED DATA - Serial data input line.
3	TXD	TRANSMITTED DATA - Serial data output line.
4	NC	Not connected.
5	CTS	CLEAR TO SEND - An output signal used to indicate ready-to-transfer data status. This pin is connected to both DSR pin 6 and DCD pin 8.
6	DSR	DATA SET READY - An output signal used to indicate an on-line/in-service/active status. This pin is connected to both CTS pin 5 and DCD pin 8.
7	SIG-GND	SIGNAL GROUND - This line provides signal ground or common return connection (common ground reference) between the EVB and RS-232C compatible terminal.
8	DCD	DATA CARRIER DETECT - An output signal used to indicate an acceptable received line (carrier) signal has been detected. This pin is connected to both CTS pin 5 and DSR pin 6.
9-19	NC	Not connected.
20	DTR	DATA TERMINAL READY - An input line used to indicate an on-line/in-service/active status.
21-25	NC	Not connected.

Table 6-3. Host I/O Port Connector (P3) Pin Assignments

Pin Number	Signal Mnemonic	Signal Name and Description
1	GND	PROTECTIVE GROUND
2	RXD	RECEIVED DATA - Serial data output line.
3	TXD	TRANSMITTED DATA - Serial data input line.
4, 5	NC	Not connected.
6	DSR	DATA SET READY - An output signal used to indicate an on-line/in-service/active status. This pin is connected to DCD pin 8.
7	SIG-GND	SIGNAL GROUND - This line provides signal ground or common return connection (common ground reference) between the EVB and RS-232C compatible host computer.
8	DCD	DATA CARRIER DETECT - An output signal used to indicate an acceptable received line (carrier) signal has been detected. This pin is connected to DSR pin 6.
9-19	NC	Not connected.
20	DTR	DATA TERMINAL READY - An input line used to indicate an on-line/in-service/active status.
21-25	NC	Not connected.

Table 6-4. Input Power Connector (P4) Pin Assignments

Pin Number	Signal Mnemonic	Signal Name and Description
1	-12 V	-12 Vdc Power - Input voltage (-12 Vdc @ 0.1 A) used by the EVB logic circuits.
2	GND	GROUND
3	+5 V	+5 Vdc Power - Input voltage (+5 Vdc @ 0.5 A) used by the EVB logic circuits.
4	+12 V	+12 Vdc Power - Input voltage (+12 Vdc @ 0.1 A) used by the EVB logic circuits.

6.3 PARTS LIST

Table 6-5 lists the components of the EVB by reference designation order. The reference designation is used to identify the particular part on the parts location diagram (Figure 6-1) that is associated with the parts list table. This parts list reflects the latest issue of hardware at the time of printing.

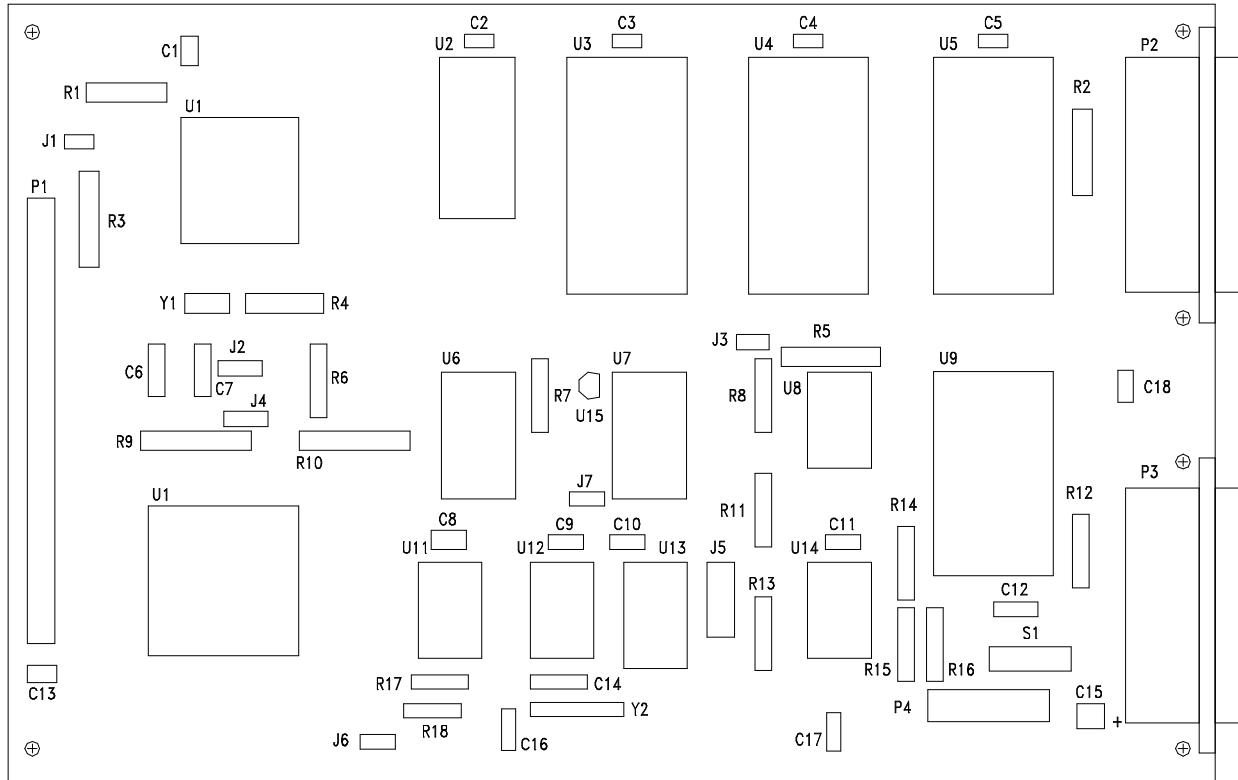

Figure 6-1. EVB Parts Location Diagram

Table 6-5. EVB Parts List

Reference Designation	Component Description
Printed Wiring Board (PWB)	M68HC11EVB
C1-C5, C8-C11, C13, C14, C17, C18	Capacitor, 0.1 uF @ 50 Vdc, +/-20%
C6, C7, C16	Capacitor, 24 pF @ 50 Vdc, +/-20%
C12	Capacitor, 1.0 uF @ 50 Vdc, +/-20%
C15	Capacitor, electrolytic, 100 uF @ 50 Vdc, +/-20%
J1, J3, J6	Header, jumper, single row post, 2 pin, Apronics # 929705-01-02
J2, J4	Header, jumper, single row post, 3 pin, Apronics # 929705-01-03
J5	Header, jumper, double row post, 12 pin, Apronics # 929715-01-06
P1	Header, double row post, 60 pin, Apronics # 929715-01-30 (MCU I/O port connector)
P2, P3	Connector, cable, 25-pin, ITT # DBP-25SAA (terminal/host I/O port connector)
P4	Terminal block, 4 position, Electrovert # 25.112.0453 (power supply connector)
R1-R3, R5-R10	Resistor, 10k ohm, 5%, 1/4W
R4	Resistor, 10M ohm, 5%, 1/4W
R11, R13-R15	Resistor, 27k ohm, 5%, 1/4W
R12	Resistor, 620 ohm, 5%, 1/4W

Table 6-5. EVB Parts List (continued)

Reference Designation	Component Description
R16	Resistor, 100k ohm, 5%, 1/4W
R17, R18	Resistor, 2.2k ohm, 5%, 1/4W
S1	Switch, push-button, SPDT, C&K #8125-R2/7527
U1	I.C., MC68HC24FN, PRU
U2	I.C., MC74HC373N, transparent latch
U3	I.C., 2764, 8k EPROM, 250 nS
U4	I.C., MCM6164, 8k RAM (user supplied)
U5	I.C., MCM6164, 8k RAM, 250 nS
U6	I.C., MC74HC138, decoder/de-multiplexer
U7	I.C., MC74HC4066/MC14066B, digital switch
U8	I.C., MC1488P, RS-232C driver
U9	I.C., MC68B50P, ACIA
U10	I.C., MC68HC11A1FN, MCU (Note 1)
U11	I.C., MC74HC74, D-type flip-flop
U12	I.C., MC74HC14, inverter
U13	I.C., MC74HC4040, binary ripple counter
U14	I.C., MC1489P, RS-232C receiver
U15	Voltage detector, 3.80-4.20 Vdc, Motorola #MC34064P or Seiko # S-8054HN
XU1	Socket, PC mount, 44 pin, PLCC, AMP # 821-551-1 (use with U1)

Table 6-5. EVB Parts List (continued)

Reference Designation	Component Description
XU3-XU5	Socket, 28 pin, DIP, Robinson Nugent # ICL-286-S7-TG (use with U3-U5)
XU9	Socket, 24 pin, DIP, Robinson Nugent # ICL-246-S7-TG (use with U9)
XU10	Socket, PC mount, 52 pin, PLCC, AMP # 821-575-1 (use with U10)
Y1	Crystal, MCU, 8.0 MHz (Notes 2 & 3)
Y2	Crystal, ACIA, 2.4576 MHz
Fabricated jumper	Apronics # 929955-00 (use with jumper headers J1-J6)

NOTES

1. MCU supplied with the EVB have the configuration (CONFIG) register ROMON bit cleared to disable MCU internal ROM, thereby allowing external EPROM containing the BUFFALO program to control EVB operations.
2. Crystal frequencies from 4 to 8 MHz (up to 8.4 MHz) can be used without any changes to the 24 pF capacitors (C6 and C7) and 10M ohm resistor (R5) values.
3. 8 MHz crystal obtains 2 MHz E-clock/9600 baud MCU SCI operation. 4 MHz crystal obtains 1 MHz E-clock/4800 baud MCU SCI operation.

6.4 DIAGRAMS

Figure 6-2 is the EVB schematic diagram.

NOTES:

1. UNLESS OTHERWISE SPECIFIED:

ALL RESISTORS ARE IN OHMS, $\pm 5\%$, 1/4W.
 ALL CAPACITORS ARE IN μF .
 ALL VOLTAGES ARE DC.

2. DEVICE TYPE NUMBERS LISTED BELOW ARE FOR REFERENCE ONLY. DEVICE TYPE NUMBER VARIES WITH MANUFACTURER.

REF DES	DEVICE TYPE	NOTES	GND	+5V	+12V	-12V
U1	MC68HC24	PRU	29	17		
U2	MC74HC373	TRANSPARENT LATCH	10	20		
U3	2764	8K EPROM (250ns)	14	28		
U4	(USER SUPPLIED)	8K RAM (250ns)	14	28		
U5	MCM6164	8K RAM (250ns)	14	28		
U6	MC74HC138	DECODER/DEMUX	8	16		
U7	MC74HC4066	DIGITAL SWITCH	7	14		
U8	MC1488P	RS-232C DRIVER	7		14	1
U9	MC68B50P	ACIA	1	12		
U10	MC68HC11A1	MCU	1	26		
U11	MC74HC74	D-TYPE FLIP-FLOP	7	14		
U12	MC74HC14	INVERTER	7	14		
U13	MC74HC4040	RIPPLE COUNTER	8	16		
U14	MC1489P	RS-232C RECEIVER	7			

3 DIGITAL SWITCH U7 OPERATES AS FOLLOWS:

CONTROL PINS (5, 6, 12, OR 13)	SWITCH OPERATION
LOGIC ZERO (0)	OFF/OPEN
LOGIC ONE (1)	ON/CLOSED

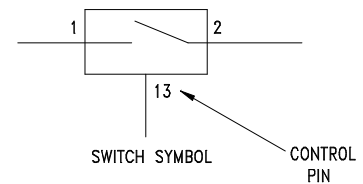

4. NOT USED DEVICE.

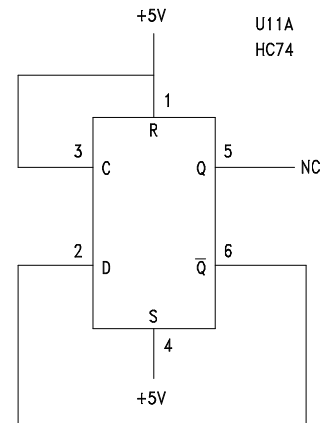

Figure 6-2. EVB Schematic Diagram (Sheet 1 of 2)

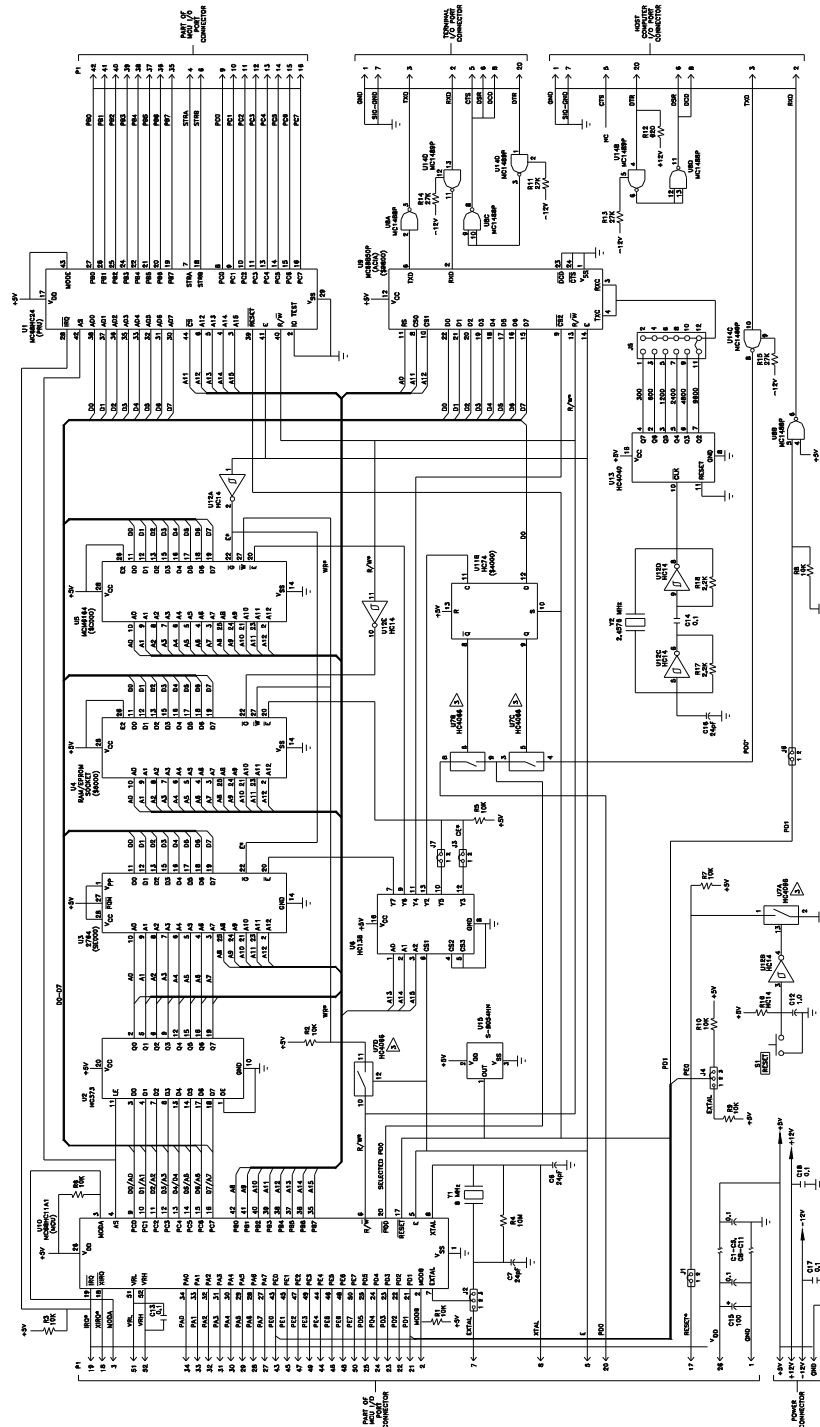

Figure 6-3. EVB Schematic Diagram (Sheet 2 of 2)

APPENDIX A

S-RECORD INFORMATION

A.1 INTRODUCTION

The S-record format for output modules was devised for the purpose of encoding programs or data files in a printable format for transportation between computer systems. The transportation process can thus be visually monitored and the S-records can be more easily edited.

A.2 S-RECORD CONTENT

When viewed by the user, S-records are essentially character strings made of several fields which identify the record type, record length, memory address, code/data, and checksum. Each byte of binary data is encoded as a 2-character hexadecimal number: the first character representing the high-order 4 bits, and the second the low-order 4 bits of the byte.

The 5 fields which comprise an S-record are shown below:

TYPE	RECORD LENGTH	ADDRESS	CODE/DATA	CHECKSUM
------	---------------	---------	-----------	----------

where the fields are composed as follows:

Field	Printable Characters	Contents
Type	2	S-record type - S0, S1, etc.
Record length	2	The count of the character pairs in the record, excluding the type and record length.
Address	4, 6, or 8	The 2-, 3-, or 4-byte address at which the data field is to be loaded into memory.
Code/data	0-2n	From 0 to n bytes of executable code, memory loadable data, or descriptive information. For compatibility with teletypewriters, some programs may limit the number of bytes to as few as 28 (56 printable characters in the S-record).
Checksum	2	The least significant byte of the one's complement of the sum of the values represented by the pairs of characters making up the record length, address, and the code/data fields.

Each record may be terminated with a CR/LF/NULL. Additionally, an S-record may have an initial field to accommodate other data such as line numbers generated by some time-sharing systems.

Accuracy of transmission is ensured by the record length (byte count) and checksum fields.

A.3 S-RECORD TYPES

Eight types of S-records have been defined to accommodate the several needs of the encoding, transportation, and decoding functions. The various Motorola upload, download, and other record transportation control programs, as well as cross assemblers, linkers, and other file-creating or debugging programs, utilize only those S-records which serve the purpose of the program. For specific information on which S-records are supported by a particular program, the user manual for that program must be consulted.

NOTE

The EVB monitor supports only the S1 and S9 records. All data before the first S1 record is ignored. Thereafter, all records must be S1 type until the S9 record terminates data transfer.

An S-record format module may contain S-records of the following types:

- S0 The header record for each block of S-records. The code/data field may contain any descriptive information identifying the following block of S-records. The address field is normally zeroes.
- S1 A record containing code/data and the 2-byte address at which the code/data is to reside.
- S2-S8 Not applicable to EVB.
- S9 A termination record for a block of S1 records. The address field may optionally contain the 2-byte address of the instruction to which control is to be passed. If not specified, the first entry point specification encountered in the object module input will be used. There is no code/data field.

Only one termination record is used for each block of S-records. Normally, only one header record is used, although it is possible for multiple header records to occur.

A.4 S-RECORD CREATION

S-record format programs may be produced by several dump utilities, debuggers, or several cross assemblers or cross linkers. Several programs are available for downloading a file in S-record format from a host system to an 8-bit or 16-bit microprocessor-based system.

A.5 S-RECORD EXAMPLE

Shown below is a typical S-record format module, as printed or displayed:

```
S00600004844521B
S1130000285F245F2212226A000424290008237C2A
S11300100002000800082629001853812341001813
S113002041E900084E42234300182342000824A952
S107003000144ED492
S9030000FC
```

The above module consists of an S0 header record, four S1 code/data records, and an S9 termination record.

The S0 header record is comprised of the following character pairs:

- S0 S-record type S0, indicating a header record.
- 06 Hexadecimal 06 (decimal 6), indicating six character pairs (or ASCII bytes) follow.
- 00 Four-character 2-byte address field, zeroes.
- 00
- 48
- 44 ASCII H, D, and R - "HDR".
- 52
- 1B Checksum of S0 record.

The first S1 code/data record is explained as follows:

- S1 S-record type S1, indicating a code/data record to be loaded/verified at a 2-byte address.
- 13 Hexadecimal 13 (decimal 19), indicating 19 character pairs, representing 19 bytes of binary data, follow.
- 00 Four-character 2-byte address field; hexadecimal address 0000, indicates location where the following data is to be loaded.

The next 16 character pairs are the ASCII bytes of the actual program code/data. In this assembly language example, the hexadecimal opcodes of the program are written in sequence in the code/data fields of the S1 records:

Opcode	Instruction
28 5F	BHCC \$0161
24 5F	BCC \$0163
22 12	BHI \$0118
22 6A	BHI \$0172
00 04 24	BRSET 0, \$04, \$012F
29 00	BHCS \$010D
08 23 7C	BRSET 4, \$23, \$018C
.	(Balance of this code is continued in the code/data
.	fields of the remaining S1 records, and stored in
.	memory location 0010, etc..)
2A	Checksum of the first S1 record.

The second and third S1 code/data records each also contain \$13 (19) character pairs and are ended with checksums 13 and 52, respectively. The fourth S1 code/data record contains 07 character pairs and has a checksum of 92.

The S9 termination record is explained as follows:

S9	S-record type S9, indicating a termination record.
03	Hexadecimal 03, indicating three character pairs (3 bytes) follow.
00	Four-character 2-byte address field, zeroes.
00	
FC	Checksum of S9 record.

Each printable character in an S-record is encoded in hexadecimal (ASCII in this example) representation of the binary bits which are actually transmitted. For example, the first S1 record above is sent as shown below.

TYPE		LENGTH			ADDRESS				CODE/DATA					CHECKSUM														
S	1	1	3		0	0	0	0	2	8	5	F	...	2	A													
5	3	3	1	3	1	3	3	3	0	3	0	3	0	3	2	3	8	3	5	4	6	...	3	2	4	1		
0101	0011	0011	0001	0011	0001	0011	0011	0011	0000	0011	0000	0011	0000	0011	0000	0011	0010	0011	1000	0011	0101	0100	0110	...	0011	0010	0100	0001

APPENDIX B

APPLICATIONS

B.1 INTRODUCTION

BUFFALO can be used with the MC68HC11 MCU in the single-chip mode as shown in Figure C-1. The only terminal interface is through the SCI port. Internally there are 54 bytes of RAM starting at \$0000, and 512 bytes internal EEPROM which can be used for developing user programs.

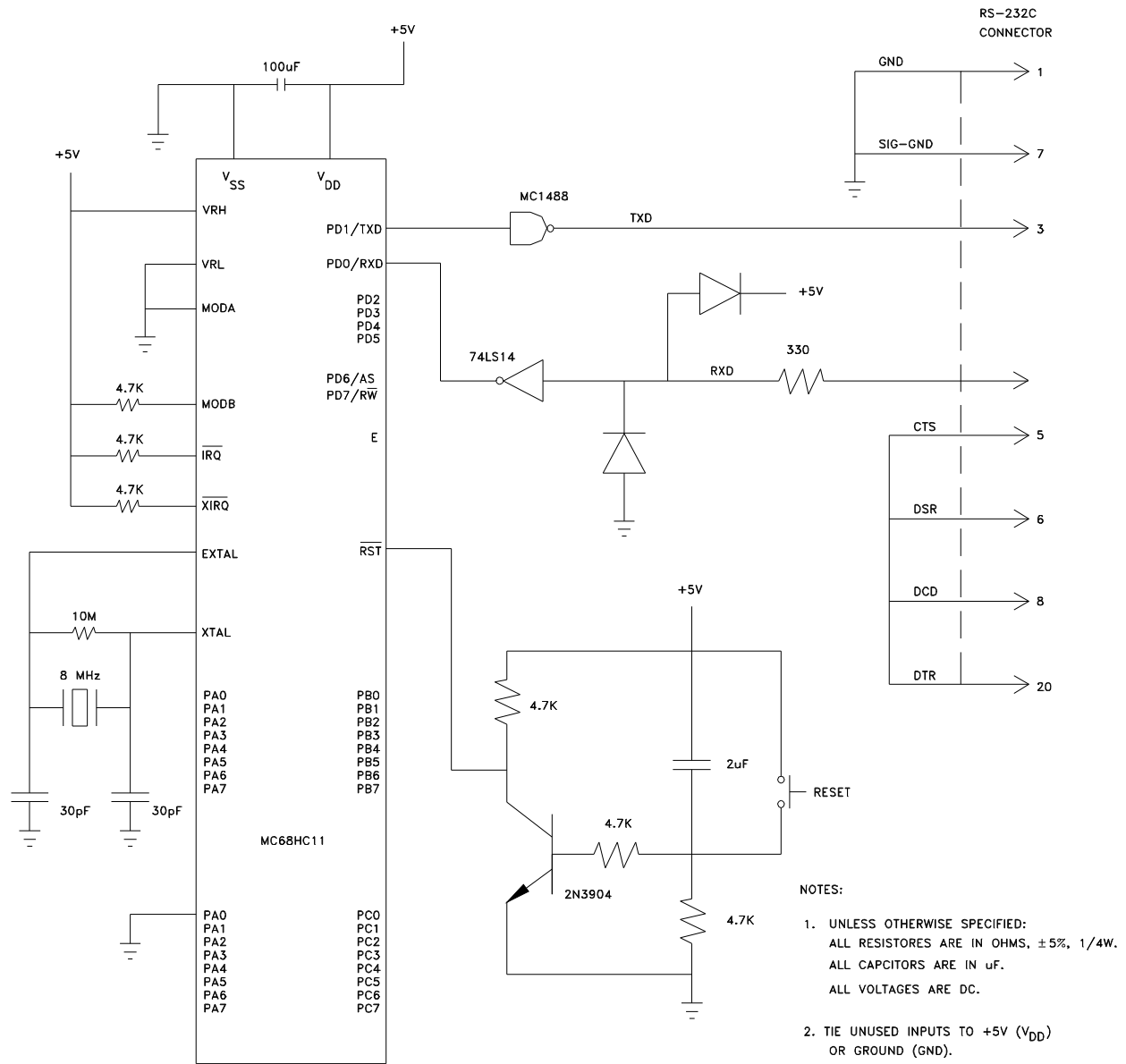

Figure B-1. Single-Chip Mode Configuration