



Intel® MAX® 10 JTAG Boundary-Scan Testing User Guide



Contents

1. Intel® MAX® 10 JTAG BST Overview.....	3
2. JTAG BST Architecture.....	4
2.1. JTAG Pins.....	4
2.2. JTAG Circuitry Functional Model.....	4
2.3. JTAG Boundary-Scan Register.....	5
2.3.1. Boundary-Scan Cells in Intel MAX 10 I/O Pin.....	5
3. BST Operation Control.....	7
3.1. JTAG IDCODE	7
3.2. JTAG Secure Mode.....	8
3.3. JTAG Private Instruction.....	8
3.4. JTAG Instructions.....	8
4. I/O Voltage Support in the JTAG Chain.....	10
5. Enabling and Disabling JTAG BST Circuitry.....	11
6. Guidelines for JTAG BST.....	12
7. Boundary-Scan Description Language Support.....	13
A. Document Revision History for the Intel MAX 10 JTAG Boundary-Scan Testing User Guide.....	14



1. Intel® MAX® 10 JTAG BST Overview

Intel® MAX® 10 devices support the IEEE Std.1149.1 (JTAG) boundary-scan testing (BST).

When you perform BST, you can test pin connections without using physical test probes and capture functional data during normal operation. The boundary-scan cells (BSCs) in a device can force signals onto pins, or capture data from pins or core logic signals. Forced test data is serially shifted in from the TDI pin to the BSCs. Captured data is serially shifted out to the TDO pin for external comparison with expected results.

Note: You can perform BST on Intel MAX 10 devices before, after, and during configuration.

Related Information

- [Intel MAX 10 FPGA Configuration User Guide](#)
Provides more information about JTAG in-system programming.
- [IEEE 1149.1 JTAG Boundary-Scan Testing in Altera Devices](#)
Provides more information on IEEE 1149.1 JTAG boundary-scan testing.
- [JTAG BST Architecture](#) on page 4
- [JTAG Boundary-Scan Register](#) on page 5
- [BST Operation Control](#) on page 7
- [I/O Voltage Support in the JTAG Chain](#) on page 10
- [Enabling and Disabling JTAG BST Circuitry](#) on page 11
- [Guidelines for JTAG BST](#) on page 12
- [Boundary-Scan Description Language Support](#) on page 13

2. JTAG BST Architecture

Intel MAX 10 JTAG interface uses four pins, TDI, TDO, TMS, and TCK.

2.1. JTAG Pins

Table 1. JTAG Pin Descriptions

Pin	Function	Description
TDI	Serial input pin for: <ul style="list-style-type: none"> Instructions Test data Programming data 	<ul style="list-style-type: none"> TDI is sampled on the rising edge of TCK TDI pins have internal weak pull-up resistors.
TDO	Serial output pin for: <ul style="list-style-type: none"> Instructions Test data Programming data 	<ul style="list-style-type: none"> TDO is sampled on the falling edge of TCK The pin is tri-stated if data is not being shifted out of the device.
TMS	Input pin that provides the control signal to determine the transitions of the TAP controller state machine.	<ul style="list-style-type: none"> TMS is sampled on the rising edge of TCK TMS pins have internal weak pull-up resistors.
TCK	The clock input to the BST circuitry.	—

All the JTAG pins are powered by the V_{CCIO} of I/O bank 1B. In JTAG mode, the I/O pins support the LVTTTL/LVCMOS 3.3-1.5V standards.

2.2. JTAG Circuitry Functional Model

The JTAG BST circuitry requires the following registers:

- Instruction register—determines which action to perform and which data register to access.
- Bypass register (1-bit long data register)—provides a minimum-length serial path between the TDI and TDO pins.
- Boundary-scan register—shift register composed of all the BSCs of the device.

Figure 1. JTAG Circuitry Functional Model

- Test access port (TAP) controller—controls the JTAG BST.
- TMS and TCK pins—operate the TAP controller.
- TDI and TDO pins—provide the serial path for the data registers.
- The TDI pin also provides data to the instruction register to generate the control logic for the data registers.

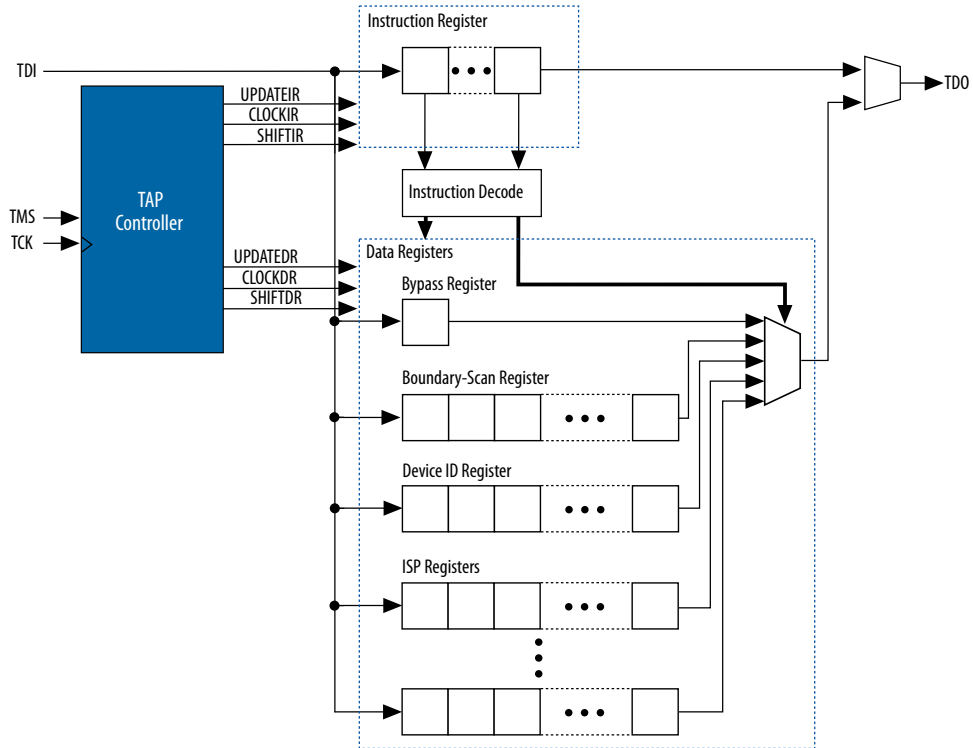

2.3. JTAG Boundary-Scan Register

You can use the boundary-scan register to test external pin connections or to capture internal data. The boundary-scan register is a large serial shift register that uses the TDI pin as an input and the TDO pin as an output. The boundary-scan register consists of 3-bit peripheral elements that are associated with Intel MAX 10 I/O pins.

2.3.1. Boundary-Scan Cells in Intel MAX 10 I/O Pin

The Intel MAX 10 3-bit BSC contains the following registers:

- Capture registers—connect to internal device data through OUTJ, OEJ, and PIN_IN signals.
- Update registers—connect to external data through PIN_OUT and PIN_OE signals.

Figure 2. User I/O BSC with JTAG BST Circuitry for Intel MAX 10 Devices

The TAP controller generates the global control signals internally for the JTAG BST registers, *shift*, *clock*, and *update*. The instruction register generates the *MODE* signal.

The data signal path for the boundary-scan register runs from the serial data in (*SDI*) signal to the serial data out (*SDO*) signal. The scan register begins at the *TDI* pin and ends at the *TDO* pin of the device.

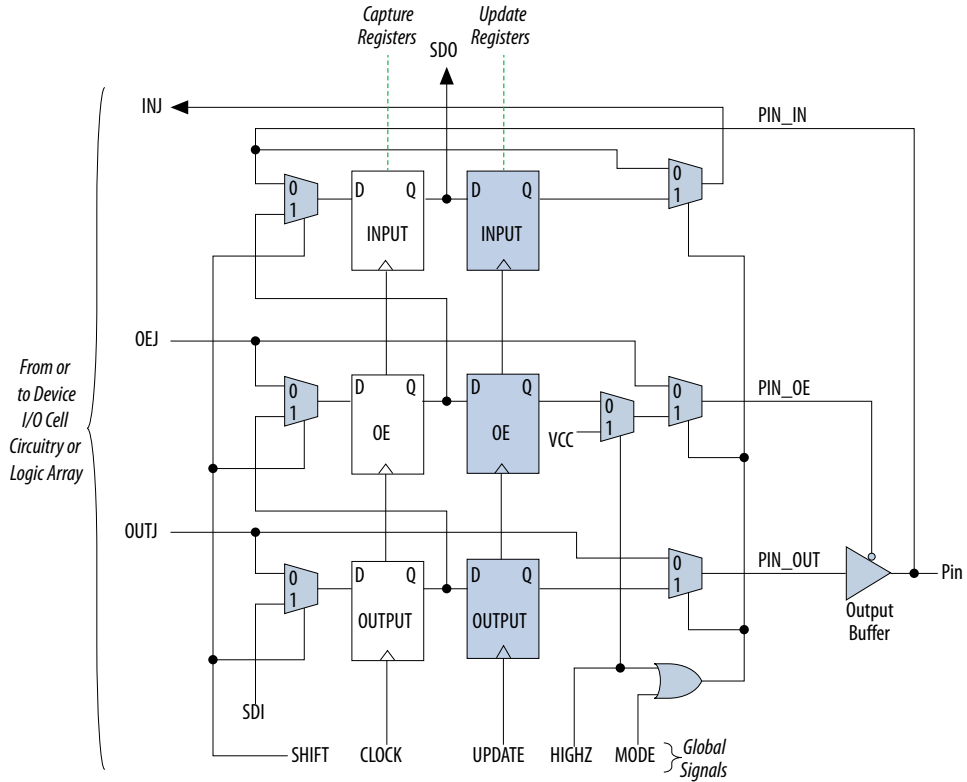

Table 2. BSC Capture and Update Register for Intel MAX 10 Devices

Pin Type	Captures			Drives		
	Output Capture Register	OE Capture Register	Input Capture Register	Output Update Register	OE Update Register	Input Update Register
User I/O	OUTJ	OEJ	PIN_IN	PIN_OUT	PIN_OE	INJ

Note: All VCC and GND pin types do not have BSCs.



3. BST Operation Control

Table 3. Boundary-Scan Register Length for Intel MAX 10 Devices

Device	Boundary-Scan Register Length
10M02	603
10M04	1080
10M08	732
10M16	1632
10M25	1164
10M40	1314
10M50	1620

3.1. JTAG IDCODE

The IDCODE is unique for each Intel MAX 10 device. Use this code to identify the devices in a JTAG chain.

Table 4. IDCODE Information for Intel MAX 10 Devices

Supply Option	Device	Device			
		Version (4 Bits)	Part Number (16 Bits)	Manufacturer Identity (11 Bits)	LSB (1 Bit)
Single-supply	10M02 (All except U324)	0000	0011 0001 1000 0001	000 0110 1110	1
	10M02 (U324)	0000	0011 0001 1001 1010	000 0110 1110	1
	10M04	0000	0011 0001 1000 1010	000 0110 1110	1
	10M08	0000	0011 0001 1000 0010	000 0110 1110	1
	10M16	0000	0011 0001 1000 0011	000 0110 1110	1
	10M25	0000	0011 0001 1000 0100	000 0110 1110	1
	10M40	0000	0011 0001 1000 1101	000 0110 1110	1
	10M50	0000	0011 0001 1000 0101	000 0110 1110	1
Dual-supply	10M02	0000	0011 0001 0000 0001	000 0110 1110	1
	10M04	0000	0011 0001 0000 1010	000 0110 1110	1
	10M08	0000	0011 0001 0000 0010	000 0110 1110	1
	10M16	0000	0011 0001 0000 0011	000 0110 1110	1

continued...

Intel Corporation. All rights reserved. Agilix, Altera, Arria, Cyclone, Enpirion, Intel, the Intel logo, MAX, Nios, Quartus and Stratix words and logos are trademarks of Intel Corporation or its subsidiaries in the U.S. and/or other countries. Intel warrants performance of its FPGA and semiconductor products to current specifications in accordance with Intel's standard warranty, but reserves the right to make changes to any products and services at any time without notice. Intel assumes no responsibility or liability arising out of the application or use of any information, product, or service described herein except as expressly agreed to in writing by Intel. Intel customers are advised to obtain the latest version of device specifications before relying on any published information and before placing orders for products or services.

*Other names and brands may be claimed as the property of others.

ISO
9001:2015
Registered

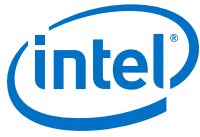

Supply Option	Device	Device			
		Version (4 Bits)	Part Number (16 Bits)	Manufacturer Identity (11 Bits)	LSB (1 Bit)
	10M25	0000	0011 0001 0000 0100	000 0110 1110	1
	10M40	0000	0011 0001 0000 1101	000 0110 1110	1
	10M50	0000	0011 0001 0000 0101	000 0110 1110	1

3.2. JTAG Secure Mode

In JTAG secure mode, the device only allows SAMPLE/PRELOAD, BYPASS, EXTEST, and IDCODE JTAG instructions.

Related Information

[MAX 10 FPGA Configuration User Guide](#)

Provides more information about the JTAG Secure Mode.

3.3. JTAG Private Instruction

Caution: Never invoke the following instruction codes. These instructions can damage the device and render it unusable:

- 10 0100 0000
- 10 0011 0000
- 10 1110 0000
- 10 0011 0001

3.4. JTAG Instructions

Table 5. JTAG Instructions Supported by Intel MAX 10 Devices

Instruction Name	Instruction Binary	Description
SAMPLE/PRELOAD	00 0000 0101	<ul style="list-style-type: none"> • Permits an initial data pattern to be an output at the device pins. • Allows you to capture and examine a snapshot of signals at the device pins if the device is operating in normal mode.
EXTEST ⁽¹⁾	00 0000 1111	<ul style="list-style-type: none"> • Forces test pattern at the output pins and capture the test results at the input pins. • Allows you to test the external circuitry and board-level interconnects.
BYPASS	11 1111 1111	<ul style="list-style-type: none"> • Places the 1-bit bypass register between the TDI and TDO pins. • Allows the BST data to pass synchronously through target devices to adjacent devices during normal device operation.
USERCODE	00 0000 0111	<ul style="list-style-type: none"> • Places the 1-bit bypass register between the TDI and TDO pins. • Allows you to shift the USERCODE register out of the TDO pin serially.

continued...

⁽¹⁾ HIGHZ, CLAMP, and EXTEST instructions do not disable weak pull-up resistors or bus hold features.



Instruction Name	Instruction Binary	Description
IDCODE	00 0000 0110	<ul style="list-style-type: none"> • Selects the IDCODE register and places it between the TDI and TDO pins. • Allows you to shift the IDCODE register out of the TDO pin serially.
HIGHZ ⁽¹⁾	00 0000 1011	<ul style="list-style-type: none"> • Places the 1-bit bypass register between the TDI and TDO pins. The 1-bit bypass register tri-states all the I/O pins. • Allow the BST data to pass synchronously through target devices to adjacent devices if device is operating in normal mode.
CLAMP ⁽¹⁾	00 0000 1010	<ul style="list-style-type: none"> • Places the 1-bit bypass register between the TDI and TDO pins. The 1-bit bypass register holds I/O pins to a state defined by the data in the boundary-scan register. • Allow the BST data to pass synchronously through target devices to adjacent devices if device is operating in normal mode.
USER0	00 0000 1100	<ul style="list-style-type: none"> • Allows you to define the scan chain between the TDI and TDO pins in the Intel MAX 10 logic array. • Use this instruction for custom logic and JTAG interfaces.
USER1	00 0000 1110	<ul style="list-style-type: none"> • Allows you to define the scan chain between the TDI and TDO pins in the Intel MAX 10 logic array. • Use this instruction for custom logic and JTAG interfaces.

4. I/O Voltage Support in the JTAG Chain

A JTAG chain can contain several Intel FPGA and non-Intel FPGA devices.

The TDO pin of a device drives out at the voltage level according to the V_{CCIO} of the device. The devices can interface with each other although the devices may have different V_{CCIO} levels.

For example, a device with 3.3-V V_{CCIO} can drive to a device with 5.0-V V_{CCIO} because 3.3 V meets the minimum V_{IH} on transistor-to-transistor logic (TTL)-level input for the 5.0-V V_{CCIO} device.

Intel MAX 10 devices can support 1.5-, 1.8-, 2.5-, or 3.3-V input levels, depending on the V_{CCIO} voltage of I/O Bank 1B.

To interface the TDI and TDO lines of the JTAG pins of devices that have different V_{CCIO} levels, insert a level shifter between the devices. If possible, construct the JTAG chain where device with a higher V_{CCIO} level drives to a device with an equal or lower V_{CCIO} level. In this setup, you only require a level shifter for shifting the TDO level to a level JTAG tester accept.

Figure 3. JTAG Chain of Mixed Voltages and Level Shifters

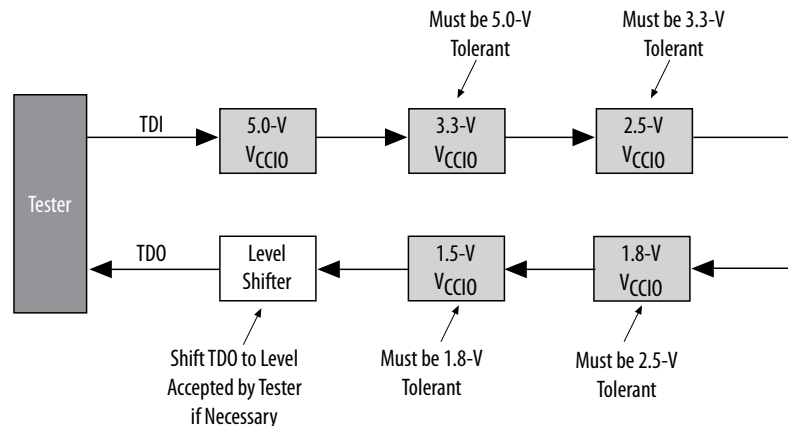

5. Enabling and Disabling JTAG BST Circuitry

The JTAG BST circuitry in Intel MAX 10 devices is automatically enabled after the power-up.

To ensure that you do not inadvertently enable the JTAG BST circuitry when it is not required, disable the circuitry permanently with pin connections as listed in the following table.

Table 6. Pin Connections to Permanently Disable the JTAG BST Circuitry in Intel MAX 10 Devices

JTAG Pins	Connection to Disable
TMS	V _{CCIO} supply of Bank 1B
TCK	GND
TDI	V _{CCIO} supply of Bank 1B
TDO	Leave open

You must enable this circuitry only if you use the BST or in-system programming (ISP) features.

6. Guidelines for JTAG BST

Consider the following guidelines when you perform BST with the device:

- If the “10...” pattern does not shift out of the instruction register through the TDO pin during the first clock cycle of the SHIFT_IR state, the TAP controller did not reach the proper state. To solve this problem, try one of the following procedures:
 - Verify that the TAP controller has reached the SHIFT_IR state correctly. To advance the TAP controller to the SHIFT_IR state, return TAP controller to the RESET state and send the 01100 code to the TMS pin.
 - Check the connections to the VCC, GND, JTAG, and dedicated configuration pins on the device.
- Perform a SAMPLE/PRELOAD test cycle before the first EXTEST test cycle to ensure that known data is present at the device pins when you enter EXTEST mode. If the OEJ update register contains 0, the data in the OUTJ update register is driven out. The state must be known and correct to avoid contention with other devices in the system.
- To perform testing before configuration, hold the nCONFIG pin low.

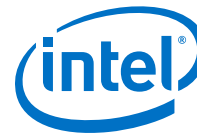

7. Boundary-Scan Description Language Support

The BSDL—a subset of VHDL—provides a syntax that allows you to describe the features of an IEEE Std. 1149.1 BST-capable device that can be tested. Test software development systems then use the BSDL files for test generation, analysis, failure diagnostics, and in-system programming.

Related Information

[IEEE 1149.1 BSDL Files](#)

Provides more information about BSC group definitions.



A. Document Revision History for the Intel MAX 10 JTAG Boundary-Scan Testing User Guide

Document Version	Changes
2020.08.11	<ul style="list-style-type: none"> Removed table: <i>IDCODE Information for 32-Bit Intel MAX 10 Devices</i>. Removed 10M01 device from the <i>Boundary-Scan Register Length for Intel MAX 10 Devices</i> table.
2019.05.10	<ul style="list-style-type: none"> Renamed the document as <i>Intel MAX 10 JTAG Boundary-Scan Testing User Guide</i>. Added single-supply device "10M02 (U324)" in <i>IDCODE Information for Intel MAX 10 Devices</i> table. Updated single-supply device "10M02" to "10M02 (All except U324)" in <i>IDCODE Information for Intel MAX 10 Devices</i> table. Added references to TDI and TDO pins for description of forced test data and captured data in <i>Intel MAX 10 JTAG BST Overview</i> chapter.

Date	Version	Changes
February 2017	2017.02.21	Rebranded as Intel.
May 2015	2015.05.04	Added note on about performing the boundary-scan testing in 'Overview'.
September 2014	2014.09.22	Initial release.

Intel Corporation. All rights reserved. Agilx, Altera, Arria, Cyclone, Enpirion, Intel, the Intel logo, MAX, Nios, Quartus and Stratix words and logos are trademarks of Intel Corporation or its subsidiaries in the U.S. and/or other countries. Intel warrants performance of its FPGA and semiconductor products to current specifications in accordance with Intel's standard warranty, but reserves the right to make changes to any products and services at any time without notice. Intel assumes no responsibility or liability arising out of the application or use of any information, product, or service described herein except as expressly agreed to in writing by Intel. Intel customers are advised to obtain the latest version of device specifications before relying on any published information and before placing orders for products or services.

*Other names and brands may be claimed as the property of others.

ISO
9001:2015
Registered