

## CHAPTER 8 ANALOG FILTERS

<b>SECTION 8.1: INTRODUCTION</b>	8.1
<b>SECTION 8.2: THE TRANSFER FUNCTION</b>	8.5
THE S-PLANE	8.5
$F_0$ and $Q$	8.7
HIGH-PASS FILTER	8.8
BAND-PASS FILTER	8.9
BAND-REJECT (NOTCH) FILTER	8.10
ALL-PASS FILTER	8.12
PHASE RESPONSE	8.14
THE EFFECT OF NONLINEAR PHASE	8.16
<b>SECTION 8.3: TIME DOMAIN RESPONSE</b>	8.19
IMPULSE RESPONSE	8.19
STEP RESPONSE	8.20
<b>SECTION 8.4: STANDARD RESPONSES</b>	8.21
BUTTERWORTH	8.21
CHEBYSHEV	8.21
BESSEL	8.23
LINEAR PHASE with EQUIRIPPLE ERROR	8.24
TRANSITIONAL FILTERS	8.24
COMPARISON OF ALL-POLE RESPONSES	8.25
ELLIPTICAL	8.26
MAXIMALLY FLAT DELAY with CHEBYSHEV STOP BAND	8.27
INVERSE CHEBYSHEV	8.27
USING THE PROTOTYPE RESPONSE CURVES	8.29
RESPONSE CURVES	
BUTTERWORTH RESPONSE	8.31
0.01 dB CHEBYSHEV RESPONSE	8.32
0.1 dB CHEBYSHEV RESPONSE	8.33
0.25 dB CHEBYSHEV RESPONSE	8.34
0.5 dB CHEBYSHEV RESPONSE	8.35
1 dB CHEBYSHEV RESPONSE	8.36
BESSEL RESPONSE	8.27
LINEAR PHASE with EQUIRIPPLE ERROR of $0.05^\circ$ RESPONSE	8.38
LINEAR PHASE with EQUIRIPPLE ERROR of $0.5^\circ$ RESPONSE	8.39
GAUSSIAN TO 12 dB RESPONSE	8.40
GAUSSIAN TO 6 dB RESPONSE	8.41

## ▣ BASIC LINEAR DESIGN

### SECTION 8.4: STANDARD RESPONSES (cont.)

#### DESIGN TABLES

BUTTERWORTH DESIGN TABLE	8.42
0.01 dB CHEBYSHEV DESIGN TABLE	8.43
0.1 dB CHEBYSHEV DESIGN TABLE	8.44
0.25 dB CHEBYSHEV DESIGN TABLE	8.45
0.5 dB CHEBYSHEV DESIGN TABLE	8.46
1 dB CHEBYSHEV DESIGN TABLE	8.47
BESSEL DESIGN TABLE	8.48
LINEAR PHASE with EQUIRIPPLE ERROR of $0.05^\circ$ DESIGN TABLE	8.49
LINEAR PHASE with EQUIRIPPLE ERROR of $0.5^\circ$ DESIGN TABLE	8.50
GAUSSIAN TO 12 dB DESIGN TABLE	8.51
GAUSSIAN TO 6 dB DESIGN TABLE	8.52
<b>SECTION 8.5: FREQUENCY TRANSFORMATION</b>	8.55
LOW-PASS TO HIGH-PASS	8.55
LOW-PASS TO BAND-PASS	8.56
LOW-PASS TO BAND-REJECT (NOTCH)	8.59
LOW-PASS TO ALL-PASS	8.61
<b>SECTION 8.6: FILTER REALIZATIONS</b>	8.63
SINGLE POLE RC	8.64
PASSIVE LC SECTION	8.65
INTEGRATOR	8.67
GENERAL IMPEDANCE CONVERTER	8.68
ACTIVE INDUCTOR	8.69
FREQUENCY DEPENDENT NEGATIVE RESISTOR (FDNR)	8.70
SALLEN-KEY	8.72
MULTIPLE FEEDBACK	8.75
STATE VARIABLE	8.77
BIQUADRATIC (BIQUAD)	8.79
DUAL AMPLIFIER BAND-PASS (DABP)	8.80
TWIN T NOTCH	8.81
BAINTER NOTCH	8.82
BOCTOR NOTCH	8.83
1 BAND-PASS NOTCH	8.85
FIRST ORDER ALL-PASS	8.86
SECOND ORDER ALL-PASS	8.87

**SECTION 8.6: FILTER REALIZATIONS (cont.)**

## DESIGN PAGES

SINGLE-POLE	8.88
SALLEN-KEY LOW-PASS	8.89
SALLEN-KEY HIGH-PASS	8.90
SALLEN-KEY BAND-PASS	8.91
MULTIPLE FEEDBACK LOW-PASS	8.92
MULTIPLE FEEDBACK HIGH-PASS	8.93
MULTIPLE FEEDBACK BAND-PASS	8.94
STATE VARIABLE	8.95
BIQUAD	8.98
DUAL AMPLIFIER BAND-PASS	8.100
TWIN T NOTCH	8.101
BAINTER NOTCH	8.102
BOCTOR NOTCH (LOW-PASS)	8.103
BOCTOR NOTCH (HIGH-PASS)	8.104
FIRST ORDER ALL-PASS	8.106
SECOND ORDER ALL-PASS	8.107

**SECTION 8.7: PRACTICAL PROBLEMS IN FILTER IMPLEMENTATION**

PASSIVE COMPONENTS	8.109
LIMITATIONS OF ACTIVE ELEMENTS (OP AMPS) IN FILTERS	8.114
DISTORTION RESULTING FROM INPUT CAPACITANCE	
MODULATION	8.115
Q PEAKING AND Q ENHANCEMENT	8.117

**SECTION 8.8: DESIGN EXAMPLES**

ANTIALIASING FILTER	8.121
TRANSFORMATIONS	8.128
CD RECONSTRUCTION FILTER	8.134
DIGITALLY PROGRAMMABLE STATE VARIABLE FILTER	8.137
60 HZ. NOTCH FILTER	8.141

**REFERENCES**

8.143

## ▣ BASIC LINEAR DESIGN

## CHAPTER 8: ANALOG FILTERS

### SECTION 8.1: INTRODUCTION

Filters are networks that process signals in a frequency-dependent manner. The basic concept of a filter can be explained by examining the frequency dependent nature of the impedance of capacitors and inductors. Consider a voltage divider where the shunt leg is a reactive impedance. As the frequency is changed, the value of the reactive impedance changes, and the voltage divider ratio changes. This mechanism yields the frequency dependent change in the input/output transfer function that is defined as the frequency response.

Filters have many practical applications. A simple, single-pole, low-pass filter (the integrator) is often used to stabilize amplifiers by rolling off the gain at higher frequencies where excessive phase shift may cause oscillations.

A simple, single-pole, high-pass filter can be used to block dc offset in high gain amplifiers or single supply circuits. Filters can be used to separate signals, passing those of interest, and attenuating the unwanted frequencies.

An example of this is a radio receiver, where the signal you wish to process is passed through, typically with gain, while attenuating the rest of the signals. In data conversion, filters are also used to eliminate the effects of aliases in A/D systems. They are used in reconstruction of the signal at the output of a D/A as well, eliminating the higher frequency components, such as the sampling frequency and its harmonics, thus smoothing the waveform.

There are a large number of texts dedicated to filter theory. No attempt will be made to go heavily into much of the underlying math: Laplace transforms, complex conjugate poles and the like, although they will be mentioned.

While they are appropriate for describing the effects of filters and examining stability, in most cases examination of the function in the frequency domain is more illuminating.

An ideal filter will have an amplitude response that is unity (or at a fixed gain) for the frequencies of interest (called the *pass band*) and zero everywhere else (called the *stop band*). The frequency at which the response changes from passband to stopband is referred to as the *cutoff frequency*.

Figure 8.1(A) shows an idealized low-pass filter. In this filter the low frequencies are in the pass band and the higher frequencies are in the stop band.

## ▣ BASIC LINEAR DESIGN

The functional complement to the low-pass filter is the high-pass filter. Here, the low frequencies are in the stop-band, and the high frequencies are in the pass band. Figure 8.1(B) shows the idealized high-pass filter.

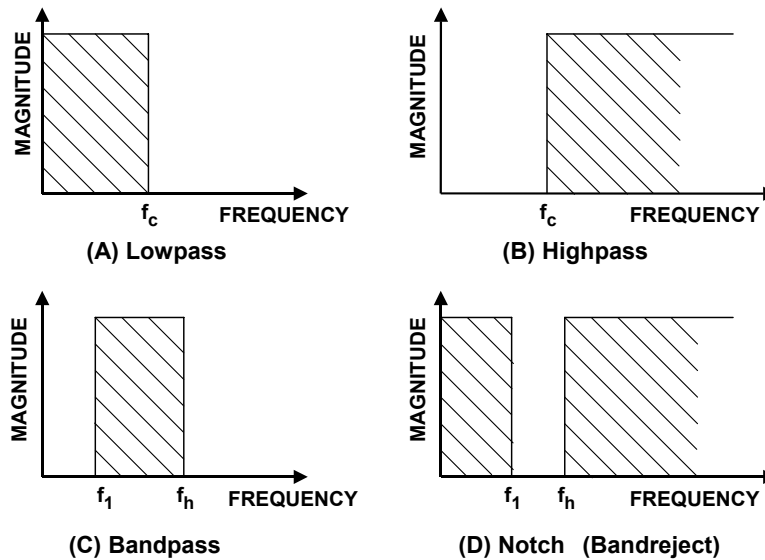

**Figure 8.1: Idealized Filter Responses**

If a high-pass filter and a low-pass filter are cascaded, a *band pass* filter is created. The band pass filter passes a band of frequencies between a lower cutoff frequency,  $f_l$ , and an upper cutoff frequency,  $f_h$ . Frequencies below  $f_l$  and above  $f_h$  are in the stop band. An idealized band pass filter is shown in Figure 8.1(C).

A complement to the band pass filter is the *band-reject*, or *notch* filter. Here, the pass bands include frequencies below  $f_l$  and above  $f_h$ . The band from  $f_l$  to  $f_h$  is in the stop band. Figure 8.1(D) shows a notch response.

The idealized filters defined above, unfortunately, cannot be easily built. The transition from pass band to stop band will not be instantaneous, but instead there will be a transition region. Stop band attenuation will not be infinite.

The five parameters of a practical filter are defined in Figure 8.2, opposite.

The *cutoff frequency* ( $F_c$ ) is the frequency at which the filter response leaves the error band (or the  $-3$  dB point for a Butterworth response filter). The *stop band frequency* ( $F_s$ ) is the frequency at which the minimum attenuation in the stopband is reached. The *pass band ripple* ( $A_{\max}$ ) is the variation (error band) in the pass band response. The *minimum pass band attenuation* ( $A_{\min}$ ) defines the minimum signal attenuation within the stop band. The steepness of the filter is defined as the *order* ( $M$ ) of the filter.  $M$  is also the number of poles in the transfer function. A pole is a root of the denominator of the transfer function. Conversely, a zero is a root of the numerator of the transfer function.

Each pole gives a  $-6$  dB/octave or  $-20$  dB/decade response. Each zero gives a  $+6$  dB/octave, or  $+20$  dB/decade response.

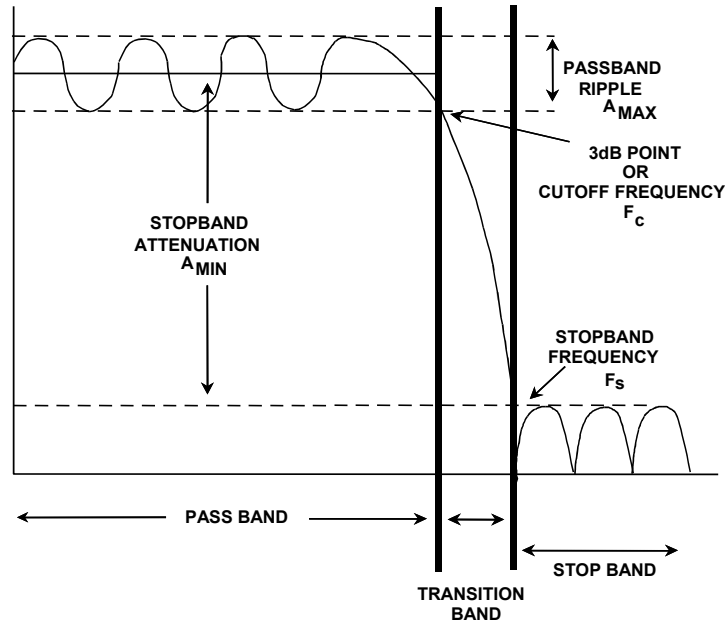

**Figure 8.2: Key Filter Parameters**

Note that not all filters will have all these features. For instance, all-pole configurations (i.e. no zeros in the transfer function) will not have ripple in the stop band. Butterworth and Bessel filters are examples of all-pole filters with no ripple in the pass band.

Typically, one or more of the above parameters will be variable. For instance, if you were to design an antialiasing filter for an ADC, you will know the cutoff frequency (the maximum frequency that you want to pass), the stop band frequency, (which will generally be the Nyquist frequency ( $= \frac{1}{2}$  the sample rate)) and the minimum attenuation required (which will be set by the resolution or dynamic range of the system). You can then go to a chart or computer program to determine the other parameters, such as filter order,  $F_0$ , and  $Q$ , which determines the peaking of the section, for the various sections and/or component values.

It should also be pointed out that the filter will affect the phase of a signal, as well as the amplitude. For example, a single-pole section will have a  $90^\circ$  phase shift at the crossover frequency. A pole pair will have a  $180^\circ$  phase shift at the crossover frequency. The  $Q$  of the filter will determine the rate of change of the phase. This will be covered more in depth in the next section.

## ▣ BASIC LINEAR DESIGN

***Notes:***



## SECTION 8.2: THE TRANSFER FUNCTION

### The S-Plane

Filters have a frequency dependent response because the impedance of a capacitor or an inductor changes with frequency. Therefore the complex impedances:

$$Z_L = s L \quad \text{Eq. 8-1}$$

and

$$Z_C = \frac{1}{s C} \quad \text{Eq. 8-2}$$

are used to describe the impedance of an inductor and a capacitor, respectively,

$$s = \sigma + j\omega \quad \text{Eq. 8-3}$$

where  $\sigma$  is the Neper frequency in nepers per second (NP/s) and  $\omega$  is the angular frequency in radians per sec (rad/s).

By using standard circuit analysis techniques, the transfer equation of the filter can be developed. These techniques include Ohm's law, Kirchoff's voltage and current laws, and superposition, remembering that the impedances are complex. The transfer equation is then:

$$H(s) = \frac{a_m s^m + a_{m-1} s^{m-1} + \dots + a_1 s + a_0}{b_n s^n + b_{n-1} s^{n-1} + \dots + b_1 s + b_0} \quad \text{Eq. 8-4}$$

Therefore,  $H(s)$  is a rational function of  $s$  with real coefficients with the degree of  $m$  for the numerator and  $n$  for the denominator. The degree of the denominator is the order of the filter. Solving for the roots of the equation determines the poles (denominator) and zeros (numerator) of the circuit. Each pole will provide a  $-6$  dB/octave or  $-20$  dB/decade response. Each zero will provide a  $+6$  dB/octave or  $+20$  dB/decade response. These roots can be real or complex. When they are complex, they occur in conjugate pairs. These roots are plotted on the  $s$  plane (complex plane) where the horizontal axis is  $\sigma$  (real axis) and the vertical axis is  $\omega$  (imaginary axis). How these roots are distributed on the  $s$  plane can tell us many things about the circuit. In order to have stability, all poles must be in the left side of the plane. If we have a zero at the origin, that is a zero in the numerator, the filter will have no response at dc (high-pass or band pass).

Assume an RLC circuit, as in Figure 8.3. Using the voltage divider concept it can be shown that the voltage across the resistor is:

$$H(s) = \frac{V_o}{V_{in}} = \frac{RCs}{LCs^2 + RCs + 1} \quad \text{Eq. 8-5}$$

## ▣ BASIC LINEAR DESIGN

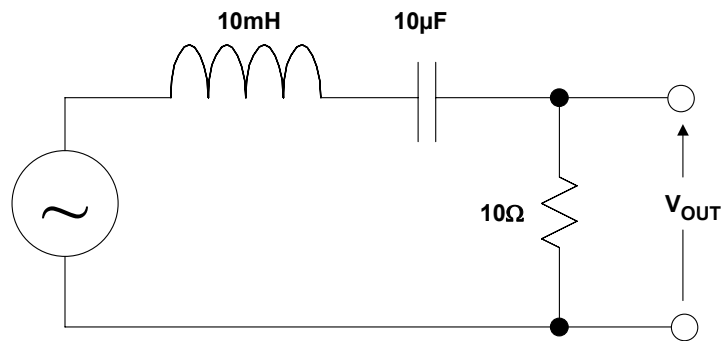

**Figure 8.3: RLC Circuit**

Substituting the component values into the equation yields:

$$H(s) = 10^3 \times \frac{s}{s^2 + 10^3s + 10^7} \quad \text{Eq. 8-6}$$

Factoring the equation and normalizing gives:

$$H(s) = 10^3 \times \frac{s}{[s - (-0.5 + j 3.122) \times 10^3] \times [s - (-0.5 - j 3.122) \times 10^3]} \quad \text{Eq 8-7}$$

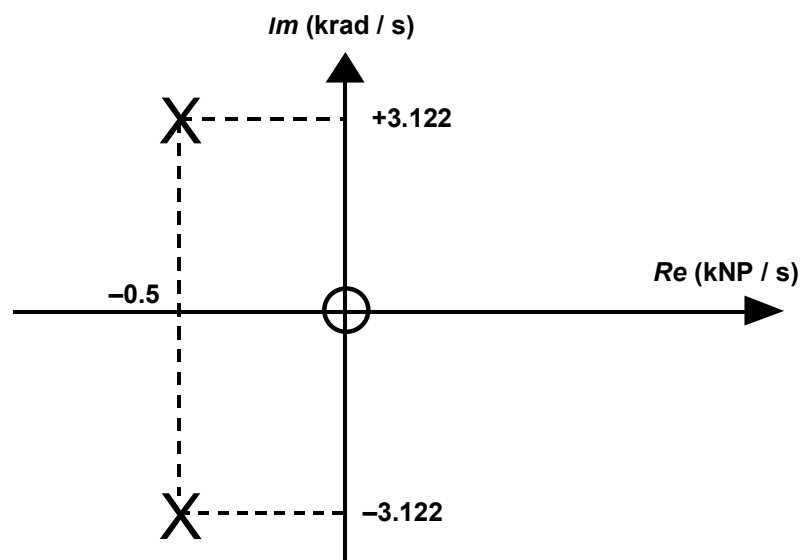

**Figure 8.4: Pole and Zero Plotted on the s-Plane**

This gives a zero at the origin and a pole pair at:

$$s = (-0.5 \pm j3.122) \times 10^3 \quad \text{Eq. 8-8}$$

Next, plot these points on the s plane as shown in Figure 8.4:

The above discussion has a definite mathematical flavor. In most cases we are more interested in the circuit's performance in real applications. While working in the s plane is completely valid, I'm sure that most of us don't think in terms of Nepers and imaginary frequencies.

### **F<sub>o</sub> and Q**

So if it is not convenient to work in the s plane, why go through the above discussion? The answer is that the groundwork has been set for two concepts that will be infinitely more useful in practice: F<sub>o</sub> and Q.

F<sub>o</sub> is the cutoff frequency of the filter. This is defined, in general, as the frequency where the response is down 3 dB from the pass band. It can sometimes be defined as the frequency at which it will fall out of the pass band. For example, a 0.1 dB Chebyshev filter can have its F<sub>o</sub> at the frequency at which the response is down > 0.1 dB.

The shape of the attenuation curve (as well as the phase and delay curves, which define the time domain response of the filter) will be the same if the ratio of the actual frequency to the cutoff frequency is examined, rather than just the actual frequency itself. Normalizing the filter to 1 rad/s, a simple system for designing and comparing filters can be developed. The filter is then scaled by the cutoff frequency to determine the component values for the actual filter.

Q is the "quality factor" of the filter. It is also sometimes given as α where:

$$\alpha = \frac{1}{Q} \quad \text{Eq. 8-9}$$

This is commonly known as the *damping ratio*. ξ is sometimes used where:

$$\xi = 2\alpha \quad \text{Eq. 8-10}$$

If Q is > 0.707, there will be some peaking in the filter response. If the Q is < 0.707, rolloff at F<sub>o</sub> will be greater; it will have a more gentle slope and will begin sooner. The amount of peaking for a 2 pole low-pass filter vs. Q is shown in Figure 8.5.

## ▣ BASIC LINEAR DESIGN

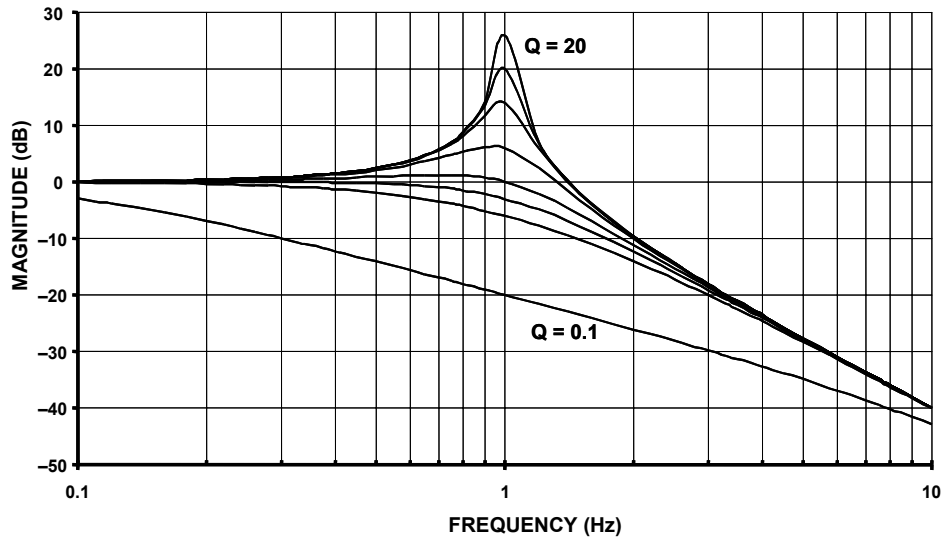

**Figure 8.5:** Low-Pass Filter Peaking vs.  $Q$

Rewriting the transfer function  $H(s)$  in terms of  $\omega_0$  and  $Q$ :

$$H(s) = \frac{H_0}{s^2 + \frac{\omega_0}{Q} s + \omega_0^2} \quad \text{Eq. 8-11}$$

where  $H_0$  is the pass-band gain and  $\omega_0 = 2\pi F_0$ .

This is now the *low-pass prototype* that will be used to design the filters.

### High-Pass Filter

Changing the numerator of the transfer equation,  $H(s)$ , of the low-pass prototype to  $H_0 s^2$  transforms the low-pass filter into a high-pass filter. The response of the high-pass filter is similar in shape to a low-pass, just inverted in frequency.

The transfer function of a high-pass filter is then:

$$H(s) = \frac{H_0 s^2}{s^2 + \frac{\omega_0}{Q} s + \omega_0^2} \quad \text{Eq. 8-12}$$

The response of a 2-pole high-pass filter is illustrated in Figure 8.6.

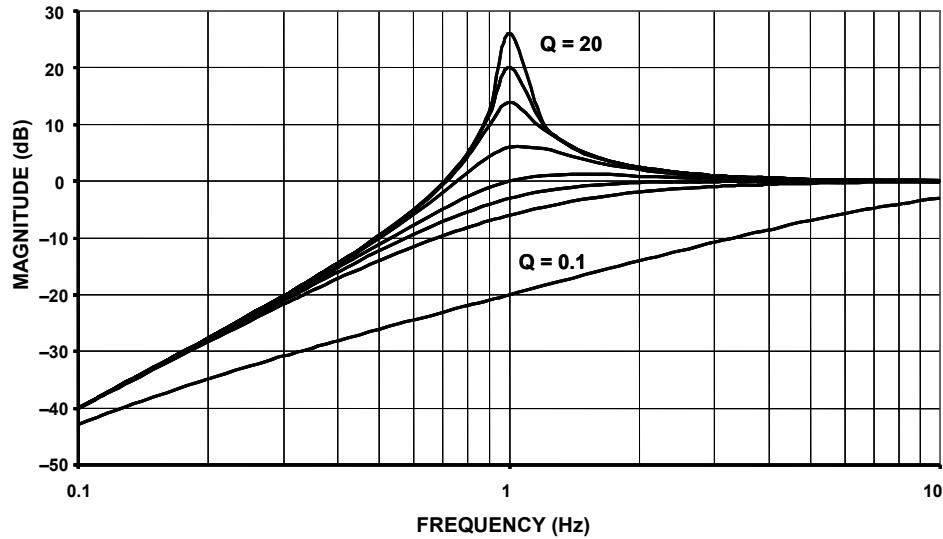

**Figure 8.6: High- Pass Filter Peaking vs. Q**

## Band-Pass Filter

Changing the numerator of the lowpass prototype to  $H_0\omega_0^2$  will convert the filter to a band-pass function.

The transfer function of a band-pass filter is then:

$$H(s) = \frac{H_0\omega_0^2}{s^2 + \frac{\omega_0}{Q}s + \omega_0^2} \quad \text{Eq. 8-13}$$

$\omega_0$  here is the frequency ( $F_0 = 2\pi\omega_0$ ) at which the gain of the filter peaks.

$H_0$  is the circuit gain and is defined:

$$H_0 = H/Q. \quad \text{Eq. 8-14}$$

Q has a particular meaning for the band-pass response. It is the selectivity of the filter. It is defined as:

$$Q = \frac{F_0}{F_H - F_L} \quad \text{Eq. 8-15}$$

where  $F_L$  and  $F_H$  are the frequencies where the response is  $-3$  dB from the maximum.

The bandwidth (BW) of the filter is described as:

It can be shown that the resonant frequency ( $F_0$ ) is the geometric mean of  $F_L$  and  $F_H$ ,

$$BW = F_H - F_L \quad \text{Eq. 8-16}$$

## ▣ BASIC LINEAR DESIGN

which means that  $F_0$  will appear half way between  $F_L$  and  $F_H$  on a logarithmic scale.

$$F_0 = \sqrt{F_H F_L} \quad \text{Eq. 8-17}$$

Also, note that the skirts of the band-pass response will always be symmetrical around  $F_0$  on a logarithmic scale.

The response of a band-pass filter to various values of  $Q$  are shown in Figure 8.7.

A word of caution is appropriate here. Band-pass filters can be defined two different ways. The narrow-band case is the classic definition that we have shown above.

In some cases, however, if the high and low cutoff frequencies are widely separated, the band-pass filter is constructed out of separate high-pass and low-pass sections. Widely separated in this context means separated by at least 2 octaves ( $\times 4$  in frequency). This is the wideband case.

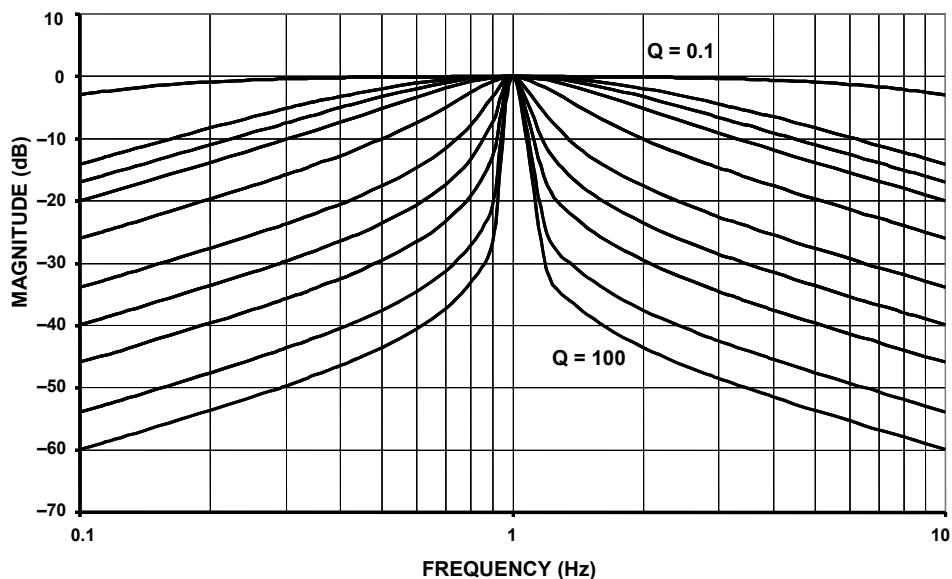

**Figure 8.7:** Band-Pass Filter Peaking vs.  $Q$

## Band-Reject (Notch) Filter

By changing the numerator to  $s^2 + \omega_z^2$ , we convert the filter to a band-reject or notch filter. As in the bandpass case, if the corner frequencies of the band-reject filter are separated by more than an octave (the wideband case), it can be built out of separate low-pass and high-pass sections. We will adopt the following convention: A narrow-band band-reject filter will be referred to as a *notch* filter and the wideband band-reject filter will be referred to as *band-reject* filter.

A notch (or band-reject) transfer function is:

$$H(s) = \frac{H_0 (s^2 + \omega_z^2)}{s^2 + \frac{\omega_0}{Q} s + \omega_0^2} \quad \text{Eq. 8-18}$$

There are three cases of the notch filter characteristics. These are illustrated in Figure 8.8 (opposite). The relationship of the pole frequency,  $\omega_0$ , and the zero frequency,  $\omega_z$ , determines if the filter is a standard notch, a lowpass notch or a highpass notch.

If the zero frequency is equal to the pole frequency a standard notch exists. In this instance the zero lies on the  $j\omega$  plane where the curve that defines the pole frequency intersects the axis.

A lowpass notch occurs when the zero frequency is greater than the pole frequency. In this case  $\omega_z$  lies outside the curve of the pole frequencies. What this means in a practical sense is that the filter's response below  $\omega_z$  will be greater than the response above  $\omega_z$ . This results in an elliptical low-pass filter.

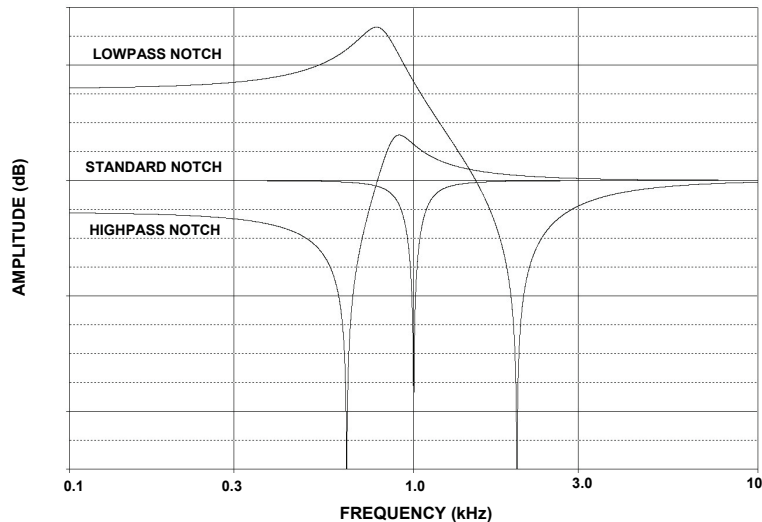

**Figure 8.8: Standard, Lowpass, and Highpass Notches**

A high-pass notch filter occurs when the zero frequency is less than the pole frequency. In this case  $\omega_z$  lies inside the curve of the pole frequencies. What this means in a practical sense is that the filter's response below  $\omega_z$  will be less than the response above  $\omega_z$ . This results in an elliptical high-pass filter.

## ▣ BASIC LINEAR DESIGN

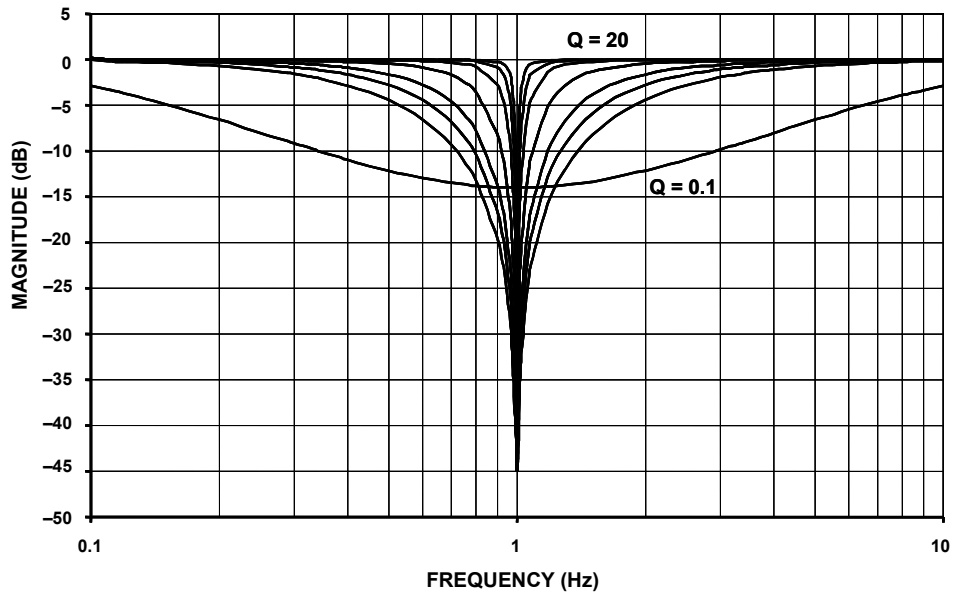

**Figure 8.9:** Notch Filter Width versus Frequency for Various Q Values

The variation of the notch width with Q is shown in Figure 8.9.

### All-pass Filter

There is another type of filter that leaves the amplitude of the signal intact but introduces phase shift. This type of filter is called an *all-pass*. The purpose of this filter is to add phase shift (delay) to the response of the circuit. The amplitude of an all-pass is unity for all frequencies. The phase response, however, changes from  $0^\circ$  to  $360^\circ$  as the frequency is swept from 0 to infinity. The purpose of an all-pass filter is to provide phase equalization, typically in pulse circuits. It also has application in single side band, suppressed carrier (SSB-SC) modulation circuits.

The transfer function of an all-pass filter is:

$$H(s) = \frac{s^2 - \frac{\omega_0}{Q} s + \omega_0^2}{s^2 + \frac{\omega_0}{Q} s + \omega_0^2} \quad \text{Eq. 8-19}$$

Note that an all-pass transfer function can be synthesized as:

$$H_{AP} = H_{LP} - H_{BP} + H_{HP} = 1 - 2H_{BP}. \quad \text{Eq. 8-20}$$

Figure 8.10 (opposite) compares the various filter types.



ANALOG FILTERS  
THE TRANSFER FUNCTION

FILTER TYPE	MAGNITUDE	POLE LOCATION	TRANSFER EQUATION
LOWPASS			$\frac{\omega_0^2}{s^2 + \frac{\omega_0}{Q}s + \omega_0^2}$
BANDPASS			$\frac{\frac{\omega_0}{Q}s}{s^2 + \frac{\omega_0}{Q}s + \omega_0^2}$
NOTCH (BANDREJECT)			$\frac{s^2 + \omega_z^2}{s^2 + \frac{\omega_0}{Q}s + \omega_0^2}$
HIGHPASS			$\frac{s^2}{s^2 + \frac{\omega_0}{Q}s + \omega_0^2}$
ALLPASS			$\frac{s^2 - \frac{\omega_0}{Q}s + \omega_0^2}{s^2 + \frac{\omega_0}{Q}s + \omega_0^2}$

*Figure 8.10: Standard Second-order Filter Responses*

## ▣ BASIC LINEAR DESIGN

### Phase Response

As mentioned earlier, a filter will change the phase of the signal as well as the amplitude. The question is, does this make a difference? Fourier analysis indicates a square wave is made up of a fundamental frequency and odd order harmonics. The magnitude and phase responses, of the various harmonics, are precisely defined. If the magnitude or phase relationships are changed, then the summation of the harmonics will not add back together properly to give a square wave. It will instead be distorted, typically showing overshoot and ringing or a slow rise time. This would also hold for any complex waveform.

Each pole of a filter will add 45° of phase shift at the corner frequency. The phase will vary from 0° (well below the corner frequency) to 90° (well beyond the corner frequency). The start of the change can be more than a decade away. In multipole filters, each of the poles will add phase shift, so that the total phase shift will be multiplied by the number of poles (180° total shift for a two pole system, 270° for a three pole system, etc.).

The phase response of a single-pole, low-pass filter is:

$$\phi(\omega) = -\arctan \frac{\omega}{\omega_o} \quad \text{Eq. 8-21}$$

The phase response of a low-pass pole pair is:

$$\begin{aligned} \phi(\omega) = & -\arctan \left[ \frac{1}{\alpha} \left( 2 \frac{\omega}{\omega_o} + \sqrt{4 - \alpha^2} \right) \right] \\ & -\arctan \left[ \frac{1}{\alpha} \left( 2 \frac{\omega}{\omega_o} - \sqrt{4 - \alpha^2} \right) \right] \end{aligned} \quad \text{Eq. 8-22}$$

For a single-pole, high-pass filter the phase response is:

$$\phi(\omega) = \frac{\pi}{2} - \arctan \frac{\omega}{\omega_o} \quad \text{Eq. 8-23}$$

The phase response of a high-pass pole pair is:

$$\begin{aligned} \phi(\omega) = & \pi - \arctan \left[ \frac{1}{\alpha} \left( 2 \frac{\omega}{\omega_o} + \sqrt{4 - \alpha^2} \right) \right] \\ & - \arctan \left[ \frac{1}{\alpha} \left( 2 \frac{\omega}{\omega_o} - \sqrt{4 - \alpha^2} \right) \right] \end{aligned} \quad \text{Eq. 8-24}$$

The phase response of a band-pass filter is:

$$\phi(\omega) = \frac{\pi}{2} - \arctan\left(\frac{2Q\omega}{\omega_0} + \sqrt{4Q^2 - 1}\right) - \arctan\left(\frac{2Q\omega}{\omega_0} - \sqrt{4Q^2 - 1}\right) \quad \text{Eq. 8-25}$$

The variation of the phase shift with frequency due to various values of Q is shown in Figure 8.11 (for low-pass, high-pass, band-pass, and all-pass) and in Figure 8.12 (for notch).

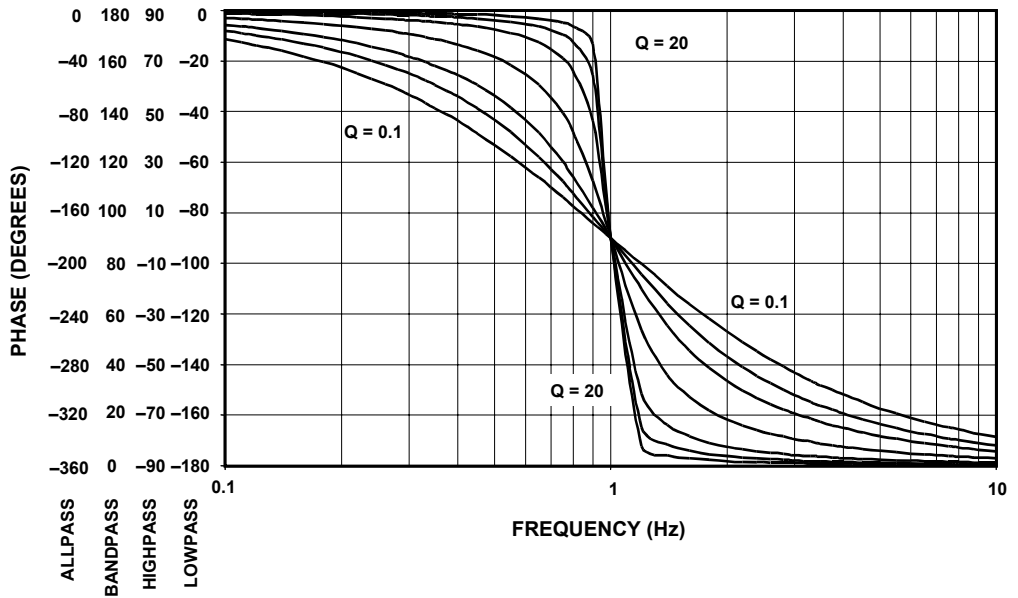

**Figure 8.11: Phase Response vs. Frequency**

## ▣ BASIC LINEAR DESIGN

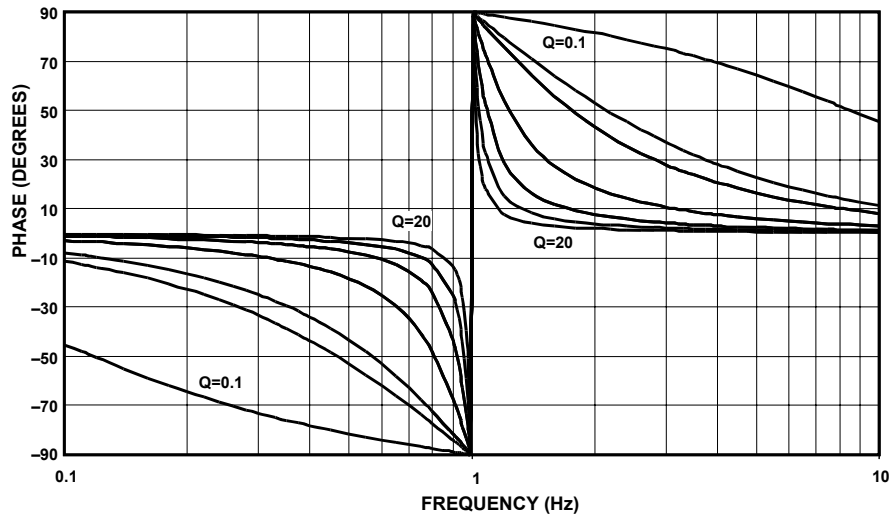

**Figure 8.12: Notch Filter Phase Response**

It is also useful to look at the change of phase with frequency. This is the group delay of the filter. A flat (constant) group delay gives best phase response, but, unfortunately, it also gives the least amplitude discrimination. The group delay of a single low-pass pole

$$\tau(\omega) = - \frac{d\phi(\omega)}{d\omega} = \frac{\cos^2 \phi}{\omega_0} \quad \text{Eq. 8-26}$$

is:

$$\tau(\omega) = \frac{2 \sin^2 \phi}{\alpha \omega_0} - \frac{\sin 2 \phi}{2 \omega} \quad \text{Eq. 8-27}$$

For the low-pass pole pair it is:

For the single high-pass pole it is:

For the high-pass pole pair it is:

$$\tau(\omega) = \frac{2 \sin^2 \phi}{\alpha \omega_0} - \frac{\sin 2 \phi}{2 \omega} \quad \text{Eq. 8-28}$$

$$\tau(\omega) = - \frac{d\phi(\omega)}{d\omega} = \frac{\sin^2 \phi}{\omega_0} \quad \text{Eq. 8-29}$$

And for the band-pass pole pair it is:

$$\tau(\omega) = \frac{2Q \cos^2 \phi}{\alpha \omega_0} + \frac{\sin 2 \phi}{2 \omega} \quad \text{Eq. 8-30}$$

### **The Effect of Nonlinear Phase**

A waveform can be represented by a series of frequencies of specific amplitude, frequency and phase relationships. For example, a square wave is:

$$F(t) = A \left( \frac{1}{2} + \frac{2}{\pi} \sin \omega t + \frac{2}{3\pi} \sin 3\omega t + \frac{2}{5\pi} \sin 5\omega t + \frac{2}{7\pi} \sin 7\omega t + \dots \right) \quad \text{Eq. 8-31}$$

If this waveform were passed through a filter, the amplitude and phase response of the filter to the various frequency components of the waveform could be different. If the phase delays were identical, the waveform would pass through the filter undistorted. If, however, the different components of the waveform were changed due to different amplitude and phase response of the filter to those frequencies, they would no longer add up in the same manner. This would change the shape of the waveform. These distortions would manifest themselves in what we typically call overshoot and ringing of the output.

Not all signals will be composed of harmonically related components. An amplitude modulated (AM) signal, for instance, will consist of a carrier and 2 sidebands at  $\pm$  the modulation frequency. If the filter does not have the same delay for the various waveform components, then “envelope delay” will occur and the output wave will be distorted.

Linear phase shift results in constant group delay since the derivative of a linear function is a constant.

## ▣ BASIC LINEAR DESIGN

**Notes:**

## SECTION 8.3: TIME DOMAIN RESPONSE

Up until now the discussion has been primarily focused on the frequency domain response of filters. The time domain response can also be of concern, particularly under transient conditions. Moving between the time domain and the frequency domain is accomplished by the use of the Fourier and Laplace transforms. This yields a method of evaluating performance of the filter to a nonsinusoidal excitation.

The transfer function of a filter is the ratio of the output to input time functions. It can be shown that the impulse response of a filter defines its bandwidth. The time domain response is a practical consideration in many systems, particularly communications, where many modulation schemes use both amplitude and phase information.

### Impulse Response

The impulse function is defined as an infinitely high, infinitely narrow pulse, with an area of unity. This is, of course, impossible to realize in a physical sense. If the impulse width is much less than the rise time of the filter, the resulting response of the filter will give a reasonable approximation actual impulse response of the filter response.

The impulse response of a filter, in the time domain, is proportional to the bandwidth of the filter in the frequency domain. The narrower the impulse, the wider the bandwidth of the filter. The pulse amplitude is equal to  $\omega_c/\pi$ , which is also proportional to the filter bandwidth, the height being taller for wider bandwidths. The pulse width is equal to  $2\pi/\omega_c$ , which is inversely proportional to bandwidth. It turns out that the product of the amplitude and the bandwidth is a constant.

It would be a nontrivial task to calculate the response of a filter without the use of Laplace and Fourier transforms. The Laplace transform converts multiplication and division to addition and subtraction, respectively. This takes equations, which are typically loaded with integration and/or differentiation, and turns them into simple algebraic equations, which are much easier to deal with. The Fourier transform works in the opposite direction.

The details of these transform will not be discussed here. However, some general observations on the relationship of the impulse response to the filter characteristics will be made.

It can be shown, as stated, that the impulse response is related to the bandwidth. Therefore, amplitude discrimination (the ability to distinguish between the desired signal from other, out of band signals and noise) and time response are inversely proportional. That is to say that the filters with the best amplitude response are the ones with the worst time response. For all-pole filters, the Chebyshev filter gives the best amplitude discrimination, followed by the Butterworth and then the Bessel.

## ▣ BASIC LINEAR DESIGN

If the time domain response were ranked, the Bessel would be best, followed by the Butterworth and then the Chebyshev. Details of the different filter responses will be discussed in the next section.

The impulse response also increases with increasing filter order. Higher filter order implies greater bandlimiting, therefore degraded time response. Each section of a multistage filter will have its own impulse response, and the total impulse response is the accumulation of the individual responses. The degradation in the time response can also be related to the fact that as frequency discrimination is increased, the  $Q$  of the individual sections tends to increase. The increase in  $Q$  increases the overshoot and ringing of the individual sections, which implies longer time response.

### Step Response

The step response of a filter is the integral of the impulse response. Many of the generalities that apply to the impulse response also apply to the step response. The slope of the rise time of the step response is equal to the peak response of the impulse. The product of the bandwidth of the filter and the rise time is a constant. Just as the impulse has a function equal to unity, the step response has a function equal to  $1/s$ . Both of these expressions can be normalized, since they are dimensionless.

The step response of a filter is useful in determining the envelope distortion of a modulated signal. The two most important parameters of a filter's step response are the overshoot and ringing. Overshoot should be minimal for good pulse response. Ringing should decay as fast as possible, so as not to interfere with subsequent pulses.

Real life signals typically aren't made up of impulse pulses or steps, so the transient response curves don't give a completely accurate estimation of the output. They are, however, a convenient figure of merit so that the transient responses of the various filter types can be compared on an equal footing.

Since the calculations of the step and impulse response are mathematically intensive, they are most easily performed by computer. Many CAD (Computer Aided Design) software packages have the ability to calculate these responses. Several of these responses are also collected in the next section.



## SECTION 8.4: STANDARD RESPONSES

There are many transfer functions that may satisfy the attenuation and/or phase requirements of a particular filter. The one that you choose will depend on the particular system. The importance of the frequency domain response versus the time domain response must be determined. Also, both of these considerations might be traded off against filter complexity, and thereby cost.

### Butterworth

The Butterworth filter is the best compromise between attenuation and phase response. It has no ripple in the pass band or the stop band, and because of this is sometimes called a maximally flat filter. The Butterworth filter achieves its flatness at the expense of a relatively wide transition region from pass band to stop band, with average transient characteristics.

The normalized poles of the Butterworth filter fall on the unit circle (in the  $s$  plane). The pole positions are given by:

$$-\sin \frac{(2K-1)\pi}{2n} + j \cos \frac{(2K-1)\pi}{2n} \quad K=1,2,\dots,n \quad \text{Eq. 8-32}$$

where  $K$  is the pole pair number, and  $n$  is the number of poles.

The poles are spaced equidistant on the unit circle, which means the angles between the poles are equal.

Given the pole locations,  $\omega_0$ , and  $\alpha$  (or  $Q$ ) can be determined. These values can then be used to determine the component values of the filter. The design tables for passive filters use frequency and impedance normalized filters. They are normalized to a frequency of 1 rad/sec and impedance of 1  $\Omega$ . These filters can be denormalized to determine actual component values. This allows the comparison of the frequency domain and/or time domain responses of the various filters on equal footing. The Butterworth filter is normalized for a  $-3$  dB response at  $\omega_0 = 1$ .

The values of the elements of the Butterworth filter are more practical and less critical than many other filter types. The frequency response, group delay, impulse response, and step response are shown in Figure 8.15. The pole locations and corresponding  $\omega_0$  and  $\alpha$  terms are tabulated in Figure 8.26.

### Chebyshev

The Chebyshev (or Chevyshev, Tschebychev, Tschebyscheff or Tchevysheff, depending on how you translate from Russian) filter has a smaller transition region than the same-order Butterworth filter, at the expense of ripples in its pass band. This filter gets its name

## ▣ BASIC LINEAR DESIGN

because the Chebyshev filter minimizes the height of the maximum ripple, which is the Chebyshev criterion.

Chebyshev filters have 0 dB relative attenuation at dc. Odd order filters have an attenuation band that extends from 0 dB to the ripple value. Even order filters have a gain equal to the pass band ripple. The number of cycles of ripple in the pass band is equal to the order of the filter.

The poles of the Chebyshev filter can be determined by moving the poles of the Butterworth filter to the right, forming an ellipse. This is accomplished by multiplying the real part of the pole by  $k_r$  and the imaginary part by  $k_I$ . The values  $k_r$  and  $k_I$  can be computed by:

$$K_r = \sinh A \quad \text{Eq. 8-33}$$

$$K_I = \cosh A \quad \text{Eq. 8-34}$$

where:

$$A = \frac{1}{n} \sinh^{-1} \frac{1}{\varepsilon} \quad \text{Eq. 8-35}$$

where n is the filter order and:

$$\varepsilon = \sqrt{10^R - 1} \quad \text{Eq. 8-36}$$

where:

$$R = \frac{R_{dB}}{10} \quad \text{Eq. 8-37}$$

where:

$$R_{dB} = \text{pass band ripple in dB} \quad \text{Eq. 8-38}$$

The Chebyshev filters are typically normalized so that the edge of the ripple band is at  $\omega_o = 1$ . The 3 dB bandwidth is given by:

$$A_{3dB} = \frac{1}{n} \cosh^{-1} \left( \frac{1}{\varepsilon} \right) \quad \text{Eq. 8-39}$$

This is tabulated in Table 1.

The frequency response, group delay, impulse response and step response are cataloged in Figures 8.16 to 8.20 on following pages, for various values of pass band ripple (0 .01 dB, 0.1 dB, 0.25 dB, 0.5 dB, and 1 dB). The pole locations and corresponding  $\omega_o$  and  $\alpha$  terms for these values of ripple are tabulated in Figures 8.27 to 8.31 on following pages.

ORDER	.01dB	.1dB	.25dB	.5dB	1dB
2	3.30362	1.93432	1.59814	1.38974	1.21763
3	1.87718	1.38899	1.25289	1.16749	1.09487
4	1.46690	1.21310	1.13977	1.09310	1.05300
5	1.29122	1.13472	1.08872	1.05926	1.03381
6	1.19941	1.09293	1.06134	1.04103	1.02344
7	1.14527	1.06800	1.04495	1.03009	1.01721
8	1.11061	1.05193	1.03435	1.02301	1.01316
9	1.08706	1.04095	1.02711	1.01817	1.01040
10	1.07033	1.03313	1.02194	1.01471	1.00842

**Table 1: 3dB Bandwidth to Ripple Bandwidth for Chebyshev Filters**

## Bessel

Butterworth filters have fairly good amplitude and transient behavior. The Chebyshev filters improve on the amplitude response at the expense of transient behavior. The Bessel filter is optimized to obtain better transient response due to a linear phase (i.e. constant delay) in the passband. This means that there will be relatively poorer frequency response (less amplitude discrimination).

The poles of the Bessel filter can be determined by locating all of the poles on a circle and separating their imaginary parts by:

$$\frac{2}{n} \quad \text{Eq. 8-40}$$

where  $n$  is the number of poles. Note that the top and bottom poles are distanced by where the circle crosses the  $j\omega$  axis by:

$$\frac{1}{n} \quad \text{Eq. 8-41}$$

or half the distance between the other poles.

The frequency response, group delay, impulse response and step response for the Bessel filters are cataloged in Figure 8.21. The pole locations and corresponding  $\omega_0$  and  $\alpha$  terms for the Bessel filter are tabulated in Figure 8.32.

## ▣ BASIC LINEAR DESIGN

### Linear Phase with Equiripple Error

The linear phase filter offers linear phase response in the pass band, over a wider range than the Bessel, and superior attenuation far from cutoff. This is accomplished by letting the phase response have ripples, similar to the amplitude ripples of the Chebyshev. As the ripple is increased, the region of constant delay extends further into the stopband. This will also cause the group delay to develop ripples, since it is the derivative of the phase response. The step response will show slightly more overshoot than the Bessel and the impulse response will show a bit more ringing.

It is difficult to compute the pole locations of a linear phase filter. Pole locations are taken from the Williams book (see Reference 2), which, in turn, comes from the Zverev book (see Reference 1).

The frequency response, group delay, impulse response and step response for linear phase filters of  $0.05^\circ$  ripple and  $0.5^\circ$  ripple are given in Figures 8.22 and 8.23. The pole locations and corresponding  $\omega_0$  and  $\alpha$  terms are tabulated in Figures 8.33 and 8.34.

### Transitional Filters

A transitional filter is a compromise between a Gaussian filter, which is similar to a Bessel, and the Chebyshev. A transitional filter has nearly linear phase shift and smooth, monotonic rolloff in the pass band. Above the pass band there is a break point beyond which the attenuation increases dramatically compared to the Bessel, and especially at higher values of  $n$ .

Two transition filters have been tabulated. These are the Gaussian to 6 dB and Gaussian to 12 dB.

The Gaussian to 6 dB filter has better transient response than the Butterworth in the pass band. Beyond the breakpoint, which occurs at  $\omega = 1.5$ , the rolloff is similar to the Butterworth.

The Gaussian to 12 dB filter's transient response is much better than Butterworth in the pass band. Beyond the 12dB breakpoint, which occurs at  $\omega = 2$ , the attenuation is less than the Butterworth.

As is the case with the linear phase filters, pole locations for transitional filters do not have a closed form method for computation. Again, pole locations are taken from Williams's book (see Reference 2). These were derived from iterative techniques.

The frequency response, group delay, impulse response and step response for Gaussian to 12 dB and 6 dB are shown in Figures 8.24 and 8.25. The pole locations and corresponding  $\omega_0$  and  $\alpha$  terms are tabulated in Figures 8.35 and 8.36.

## Comparison of All-Pole Responses

The responses of several all-pole filters, namely the Bessel, Butterworth, and Chebyshev (in this case of 0.5 dB ripple) will now be compared. An 8 pole filter is used as the basis for the comparison. The responses have been normalized for a cutoff of 1 Hz. Comparing Figures 8.13 and 8.14 below, it is easy to see the trade-offs in the response types. Moving from Bessel through Butterworth to Chebyshev, notice that the amplitude discrimination improves as the transient behavior gets progressively poorer.

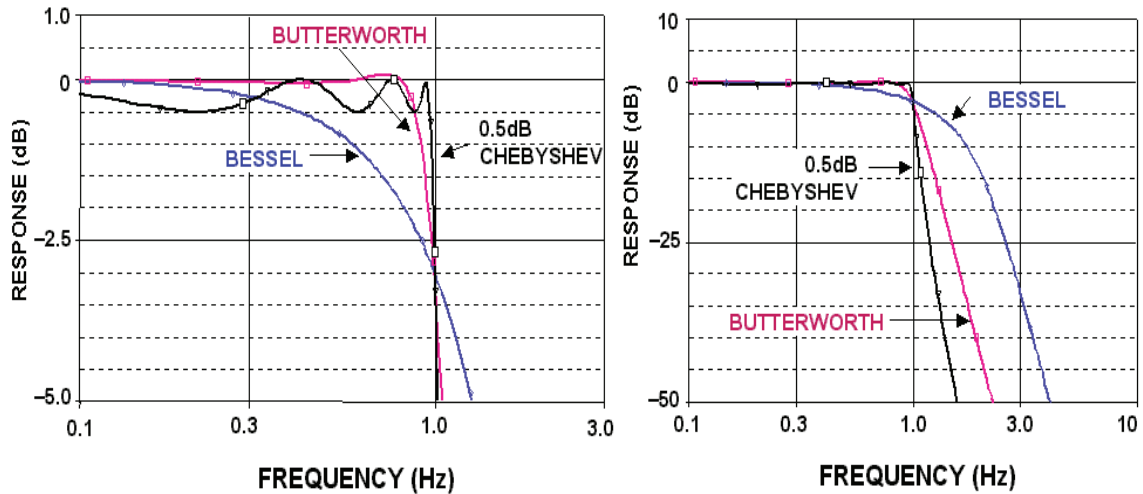

**Figure 8.13:** Comparison of Amplitude Response of Bessel, Butterworth, and Chebyshev Filters

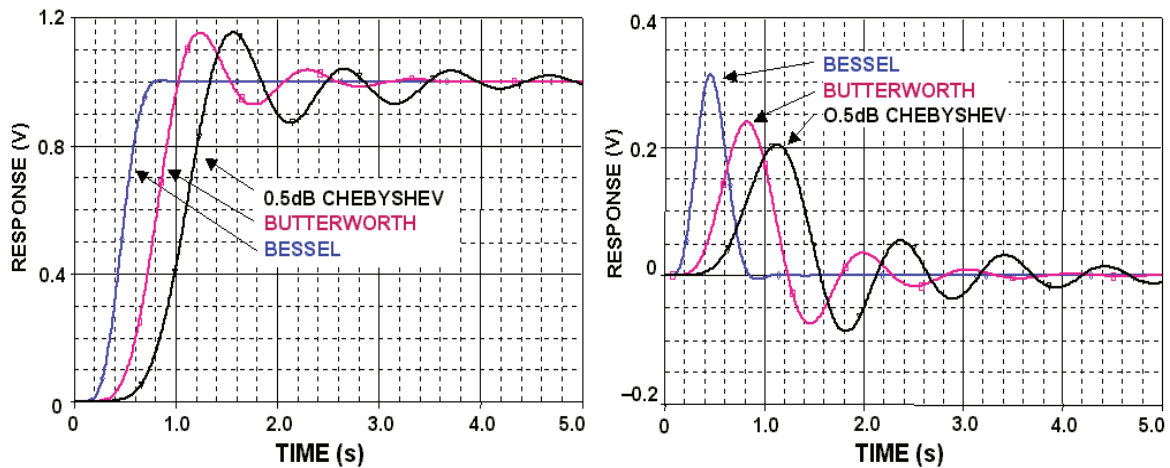

**Figure 8.14:** Comparison of Step and Impulse Responses of Bessel, Butterworth, and Chebyshev Filters

## ▣ BASIC LINEAR DESIGN

### Elliptical

The previously mentioned filters are all-pole designs, which mean that the zeros of the transfer function (roots of the numerator) are at one of the two extremes of the frequency range (0 or  $\infty$ ). For a low-pass filter, the zeros are at  $f = \infty$ . If finite frequency transfer function zeros are added to poles an Elliptical filter (sometimes referred to as Cauer filters) is created. This filter has a shorter transition region than the Chebyshev filter because it allows ripple in both the stop band and pass band. It is the addition of zeros in the stop band that causes ripple in the stop band but gives a much higher rate of attenuation, the most possible for a given number of poles. There will be some “bounceback” of the stop band response between the zeros. This is the stop band ripple. The Elliptical filter also has degraded time domain response.

Since the poles of an elliptic filter are on an ellipse, the time response of the filter resembles that of the Chebyshev.

An Elliptic filter is defined by the parameters shown in Figure 8.2, those being  $A_{\max}$ , the maximum ripple in the passband,  $A_{\min}$ , the minimum attenuation in the stopband,  $F_c$ , the cutoff frequency, which is where the frequency response leaves the pass band ripple and  $F_s$ , the stopband frequency, where the value of  $A_{\max}$  is reached.

An alternate approach is to define a filter order  $n$ , the modulation angle,  $\theta$ , which defines the rate of attenuation in the transition band, where:

$$\theta = \sin^{-1} \frac{1}{F_s} \quad \text{Eq. 8-42}$$

and  $\rho$  which determines the pass band ripple, where:

$$\rho = \sqrt{\frac{\epsilon^2}{1 + \epsilon^2}} \quad \text{Eq. 8-43}$$

where  $\epsilon$  is the ripple factor developed for the Chebyshev response, and the pass band ripple is:

$$R_{\text{dB}} = -10 \log (1 - \rho^2) \quad \text{Eq. 8-44}$$

Some general observations can be made. For a given filter order  $n$ , and  $\theta$ ,  $A_{\min}$  increases as the ripple is made larger. Also, as  $\theta$  approaches  $90^\circ$ ,  $F_s$  approaches  $F_c$ . This results in extremely short transition region, which means sharp rolloff. This comes at the expense of lower  $A_{\min}$ .

As a side note,  $\rho$  determines the input resistance of a passive elliptical filter, which can then be related to the VSWR (Voltage Standing Wave Ratio).

Because of the number of variables in the design of an elliptic filter, it is difficult to provide the type of tables provided for the previous filter types. Several CAD (Computer Aided Design) packages can provide the design values. Alternatively several sources,

such as Williams's (see Reference 2), provide tabulated filter values. These tables classify the filter by

$$C \ n \ \rho \ \theta$$

where the C denotes Cauer. Elliptical filters are sometime referred to as Cauer filters after the network theorist Wilhelm Cauer.

### **Maximally Flat Delay with Chebyshev Stop Band**

Bessel type (Bessel, linear phase with equiripple error and transitional) filters give excellent transient behavior, but less than ideal frequency discrimination. Elliptical filters give better frequency discrimination, but degraded transient response. A maximally flat delay with Chebyshev stop band filter takes a Bessel type function and adds transmission zeros. The constant delay properties of the Bessel type filter in the pass band are maintained, and the stop band attenuation is significantly improved. The step response exhibits no overshoot or ringing, and the impulse response is clean, with essentially no oscillatory behavior. Constant group delay properties extend well into the stop band for increasing n.

As with the elliptical filter, numeric evaluation is difficult. Williams's book (see Reference 2) tabulates passive prototypes normalized component values.

### **Inverse Chebyshev**

The Chebyshev response has ripple in the pass band and a monotonic stop band. The inverse Chebyshev response can be defined that has a monotonic pass band and ripple in the stop band. The inverse Chebyshev has better pass band performance than even the Butterworth. It is also better than the Chebyshev, except very near the cutoff frequency. In the transition band, the inverse Chebyshev has the steepest rolloff. Therefore, the inverse Chebyshev will meet the  $A_{\min}$  specification at the lowest frequency of the three. In the stop band there will, however, be response lobes which have a magnitude of:

$$\frac{\epsilon^2}{(1 - \epsilon)} \qquad \text{Eq. 8-45}$$

where  $\epsilon$  is the ripple factor defined for the Chebyshev case. This means that deep into the stop band, both the Butterworth and Chebyshev will have better attenuation, since they are monotonic in the stop band. In terms of transient performance, the inverse Chebyshev lies midway between the Butterworth and the Chebyshev.

## ▣ BASIC LINEAR DESIGN

The inverse Chebyshev response can be generated in three steps. First take a Chebyshev low pass filter. Then subtract this response from 1. Finally, invert in frequency by replacing  $\omega$  with  $1/\omega$ .

These are by no means all the possible transfer functions, but they do represent the most common.



## Using the Prototype Response Curves

In the following pages, the response curves and the design tables for several of the low pass prototypes of the all-pole responses will be cataloged. All the curves are normalized to a  $-3$  dB cutoff frequency of 1 Hz. This allows direct comparison of the various responses. In all cases the amplitude response for the 2 through 10 pole cases for the frequency range of 0.1 Hz. to 10 Hz. will be shown. Then a detail of the amplitude response in the 0.1 Hz to 2 Hz. pass band will be shown. The group delay from 0.1 Hz to 10 Hz and the impulse response and step response from 0 seconds to 5 seconds will also be shown.

To use these curves to determine the response of real life filters, they must be denormalized. In the case of the amplitude responses, this is simply accomplished by multiplying the frequency axis by the desired cutoff frequency  $F_C$ . To denormalize the group delay curves, we divide the delay axis by  $2\pi F_C$ , and multiply the frequency axis by  $F_C$ , as before. Denormalize the step response by dividing the time axis by  $2\pi F_C$ . Denormalize the impulse response by dividing the time axis by  $2\pi F_C$  and multiplying the amplitude axis by the same amount.

For a high-pass filter, simply invert the frequency axis for the amplitude response. In transforming a low-pass filter into a high-pass (or band-reject) filter, the transient behavior is not preserved. Zverev (see Reference 1) provides a computational method for calculating these responses.

In transforming a lowpass into a narrowband bandpass, the 0Hz axis is moved to the center frequency  $F_0$ . It stands to reason that the response of the bandpass case around the center frequency would then match the lowpass response around 0Hz. The frequency response curve of a lowpass filter actually mirrors itself around 0Hz, although we generally don't concern ourselves with negative frequency.

To denormalize the group delay curve for a bandpass filter, divide the delay axis by  $\pi BW$ , where  $BW$  is the 3dB bandwidth in Hz. Then multiply the frequency axis by  $BW/2$ . In general, the delay of the bandpass filter at  $F_0$  will be twice the delay of the lowpass prototype with the same bandwidth at 0Hz. This is due to the fact that the lowpass to bandpass transformation results in a filter with order  $2n$ , even though it is typically referred to it as having the same order as the lowpass filter from which it is derived. This approximation holds for narrow-band filters. As the bandwidth of the filter is increased, some distortion of the curve occurs. The delay becomes less symmetrical, peaking below  $F_0$ .

The envelope of the response of a band-pass filter resembles the step response of the lowpass prototype. More exactly, it is almost identical to the step response of a low-pass filter having half the bandwidth. To determine the envelope response of the band-pass filter, divide the time axis of the step response of the lowpass prototype by  $\pi BW$ , where  $BW$  is the 3dB bandwidth. The previous discussions of overshoot, ringing, etc. can now be applied to the carrier envelope.

## ▣ BASIC LINEAR DESIGN

The envelope of the response of a narrow-band band-pass filter to a short burst of carrier (that is where the burst width is much less than the rise time of the denormalized step response of the band-pass filter) can be determined by denormalizing the impulse response of the low-pass prototype. To do this, multiply the amplitude axis and divide the time axis by  $\pi BW$ , where  $BW$  is the 3 dB bandwidth. It is assumed that the carrier frequency is high enough so that many cycles occur during the burst interval.

While the group delay, step and impulse curves cannot be used directly to predict the distortion to the waveform caused by the filter, they are a useful figure of merit when used to compare filters.

**ANALOG FILTERS  
STANDARD RESPONSES**

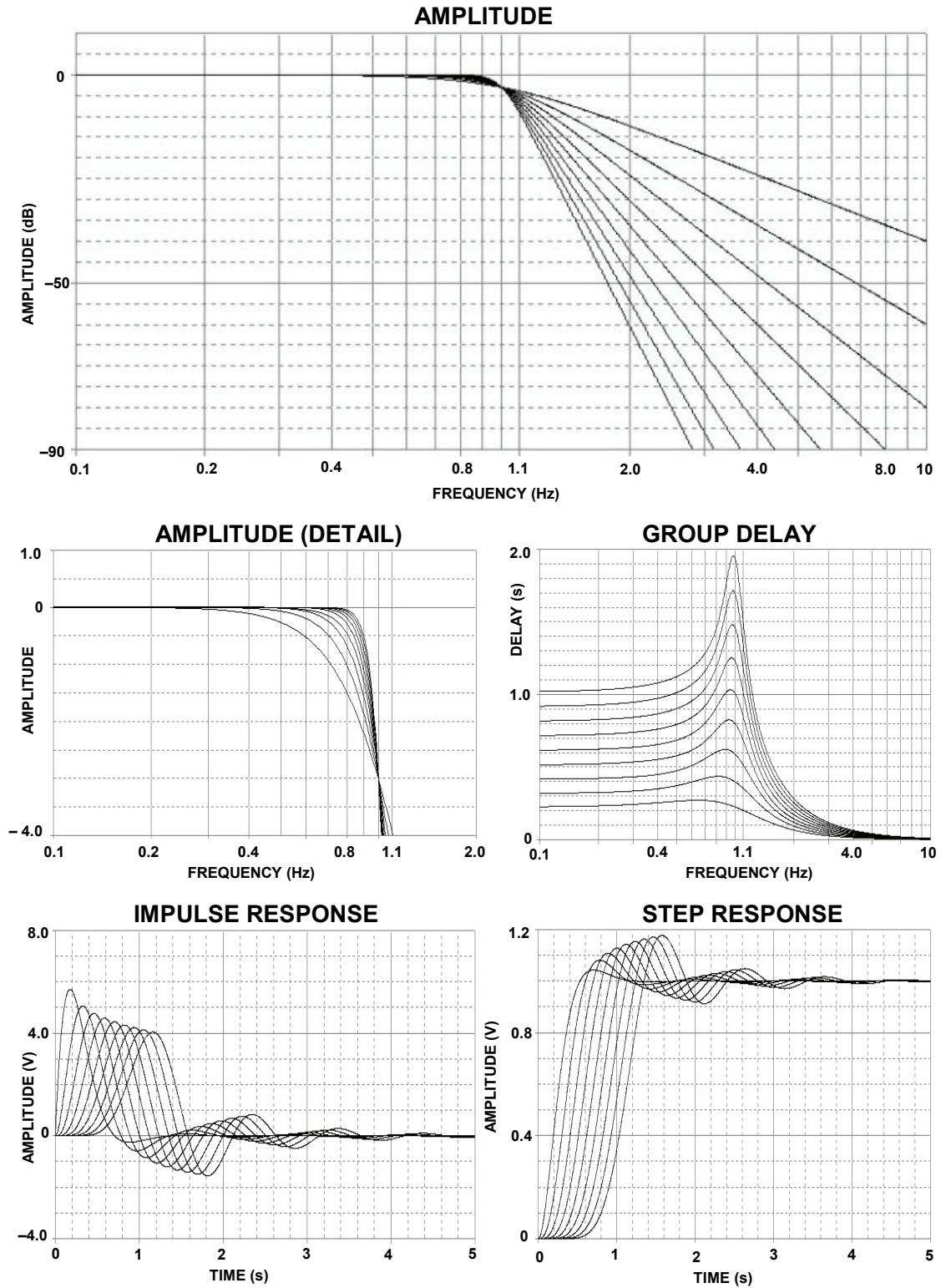

*Figure 8.15: Butterworth Response*

## ▣ BASIC LINEAR DESIGN

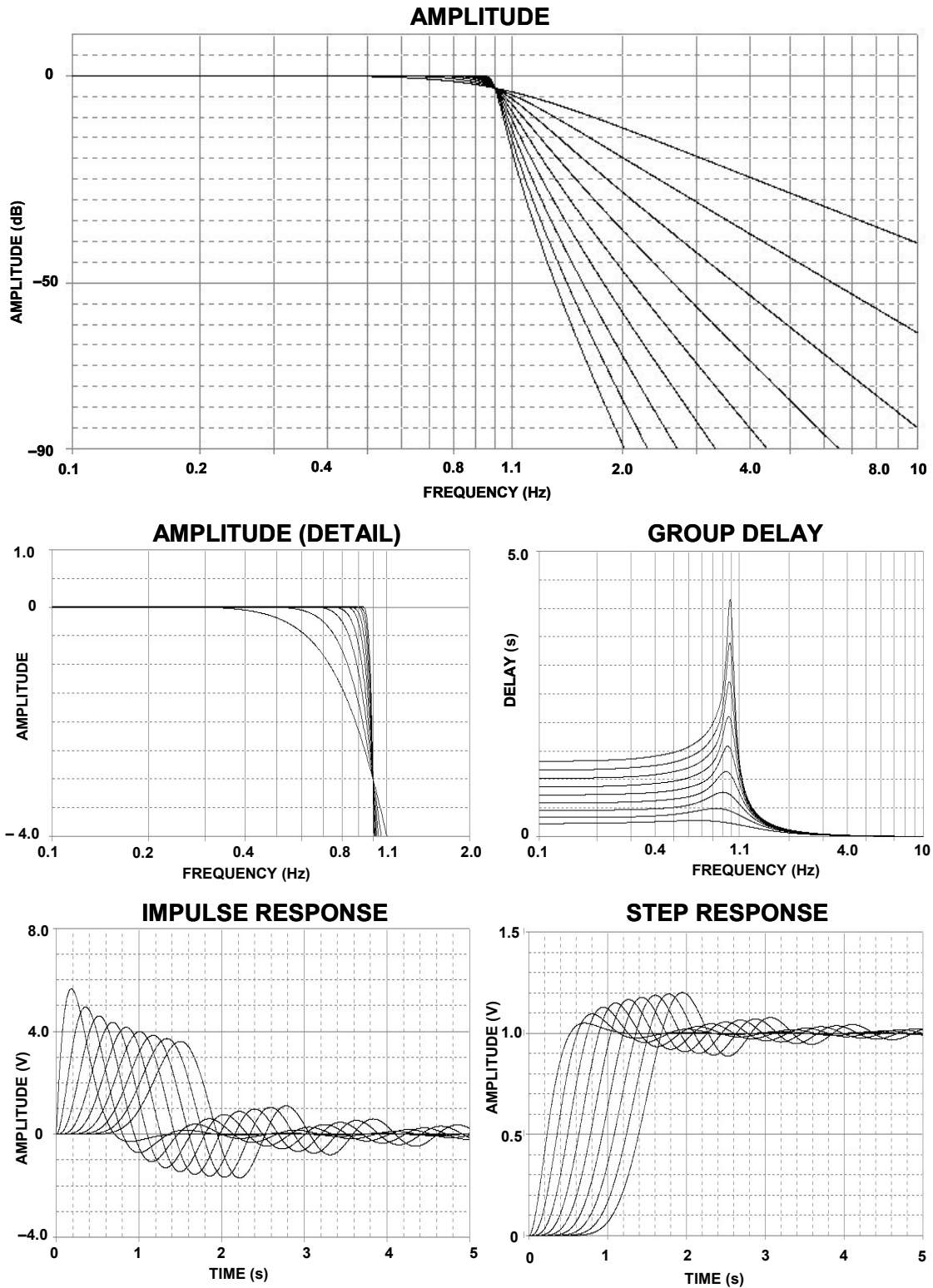

*Figure 8.16: 0.01 dB Chebyshev Response*

ANALOG FILTERS  
STANDARD RESPONSES

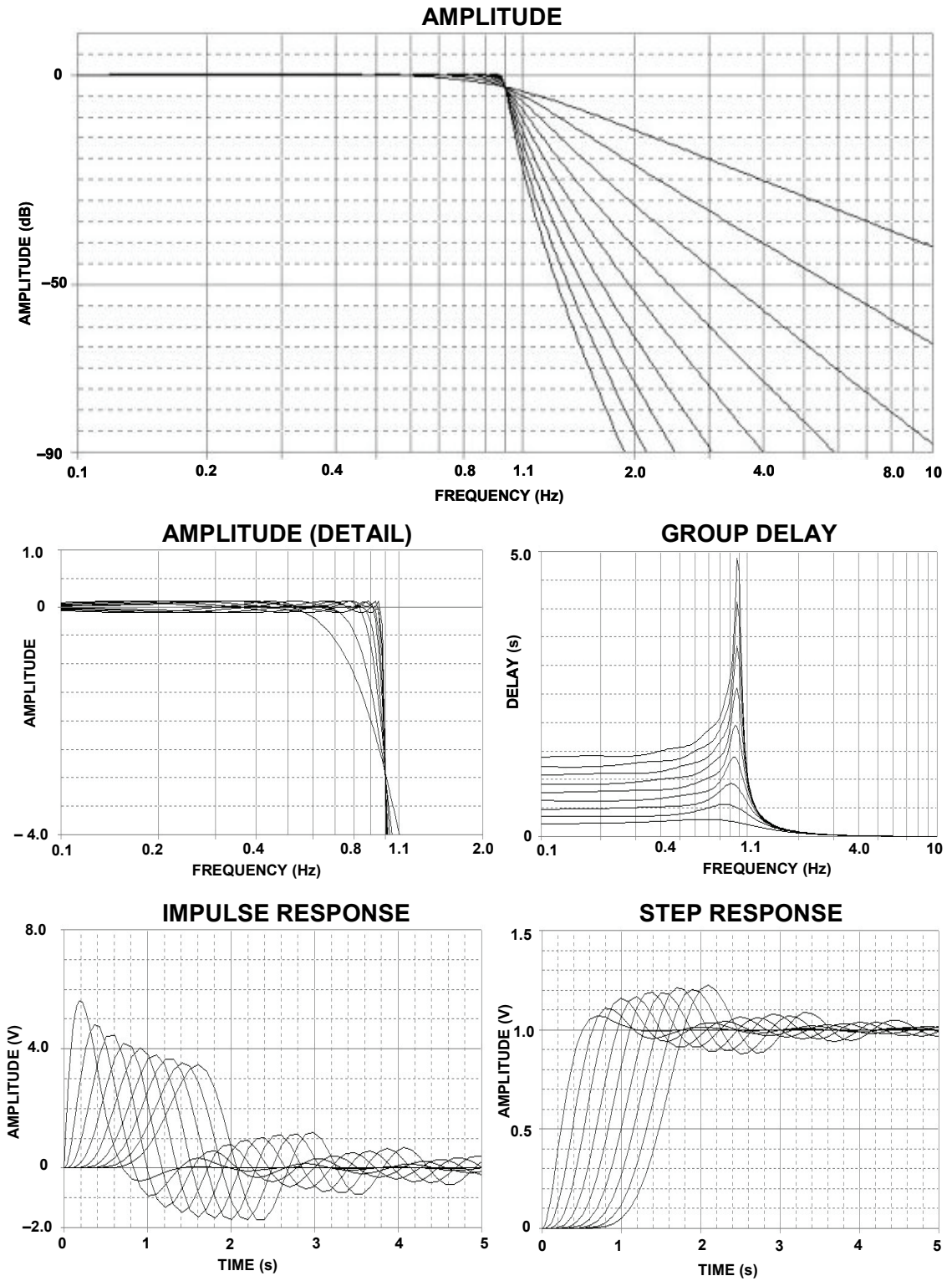
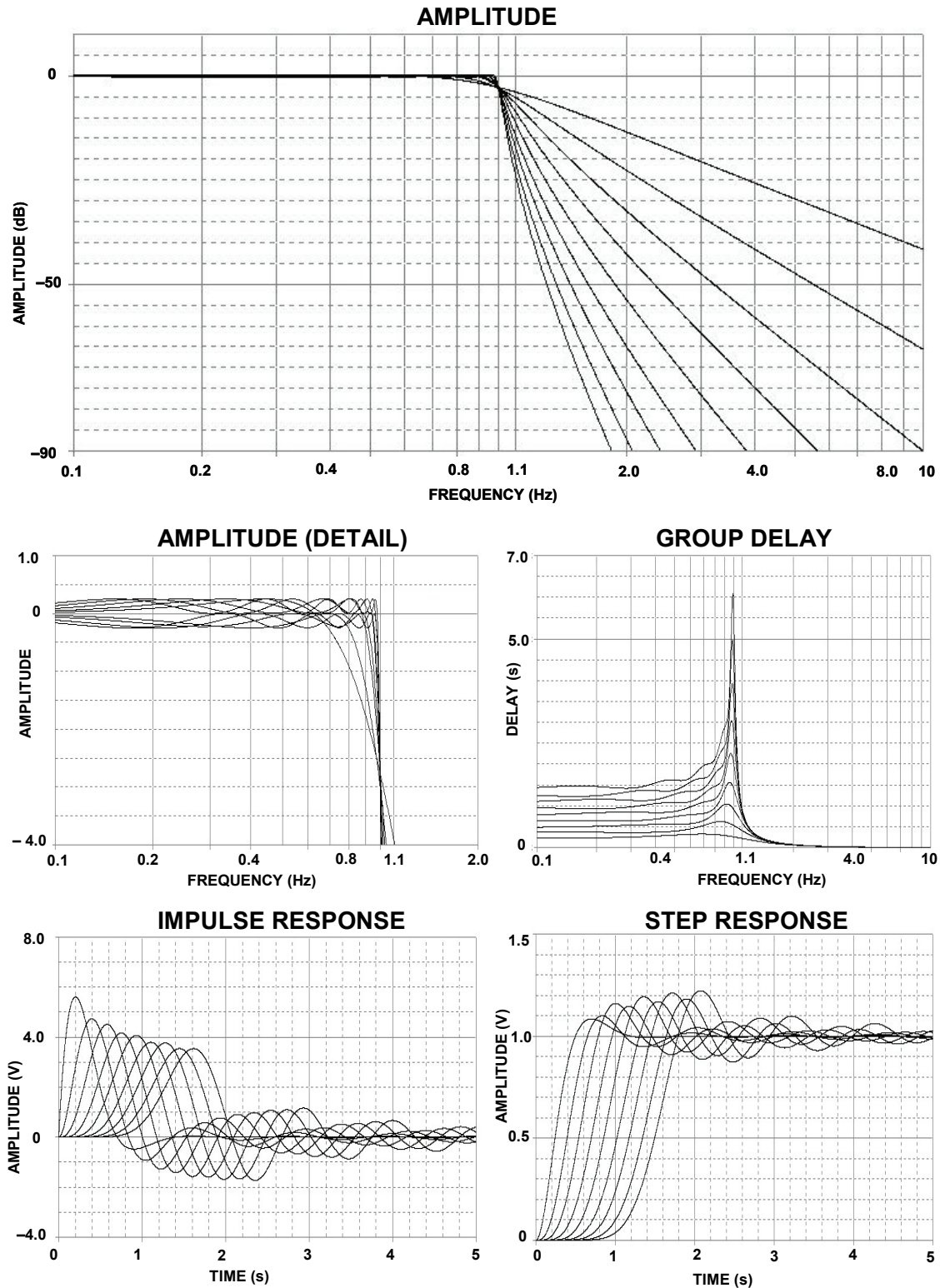

Figure 8.17: 0.1 dB Chebyshev Response



# ▣ BASIC LINEAR DESIGN



*Figure 8.18: 0.25 dB Chebyshev Response*

ANALOG FILTERS  
STANDARD RESPONSES

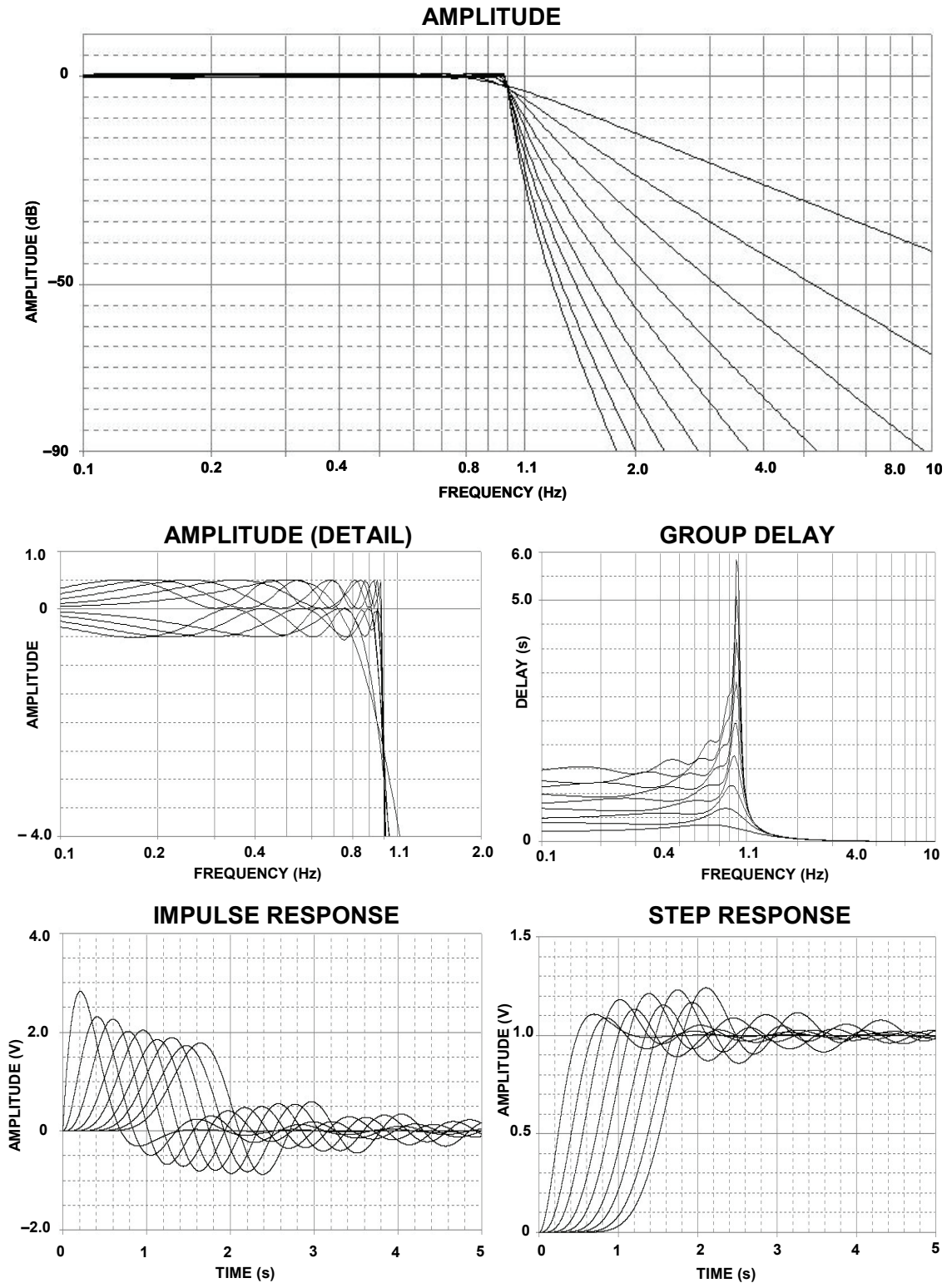
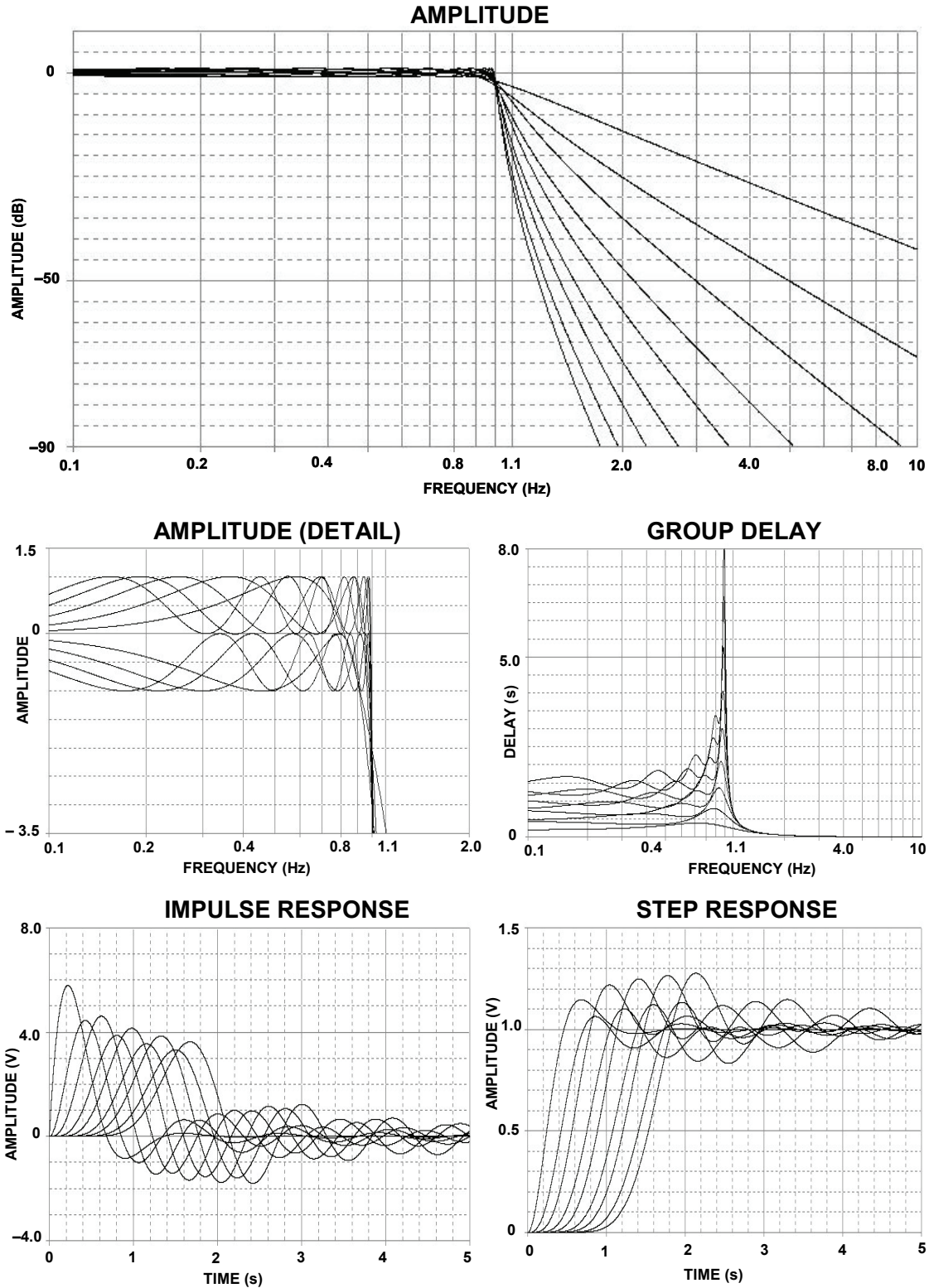

Figure 8.19: 0.5 dB Chebyshev Response

# ▣ BASIC LINEAR DESIGN



*Figure 8.20: 1 dB Chebyshev Response*



ANALOG FILTERS  
STANDARD RESPONSES

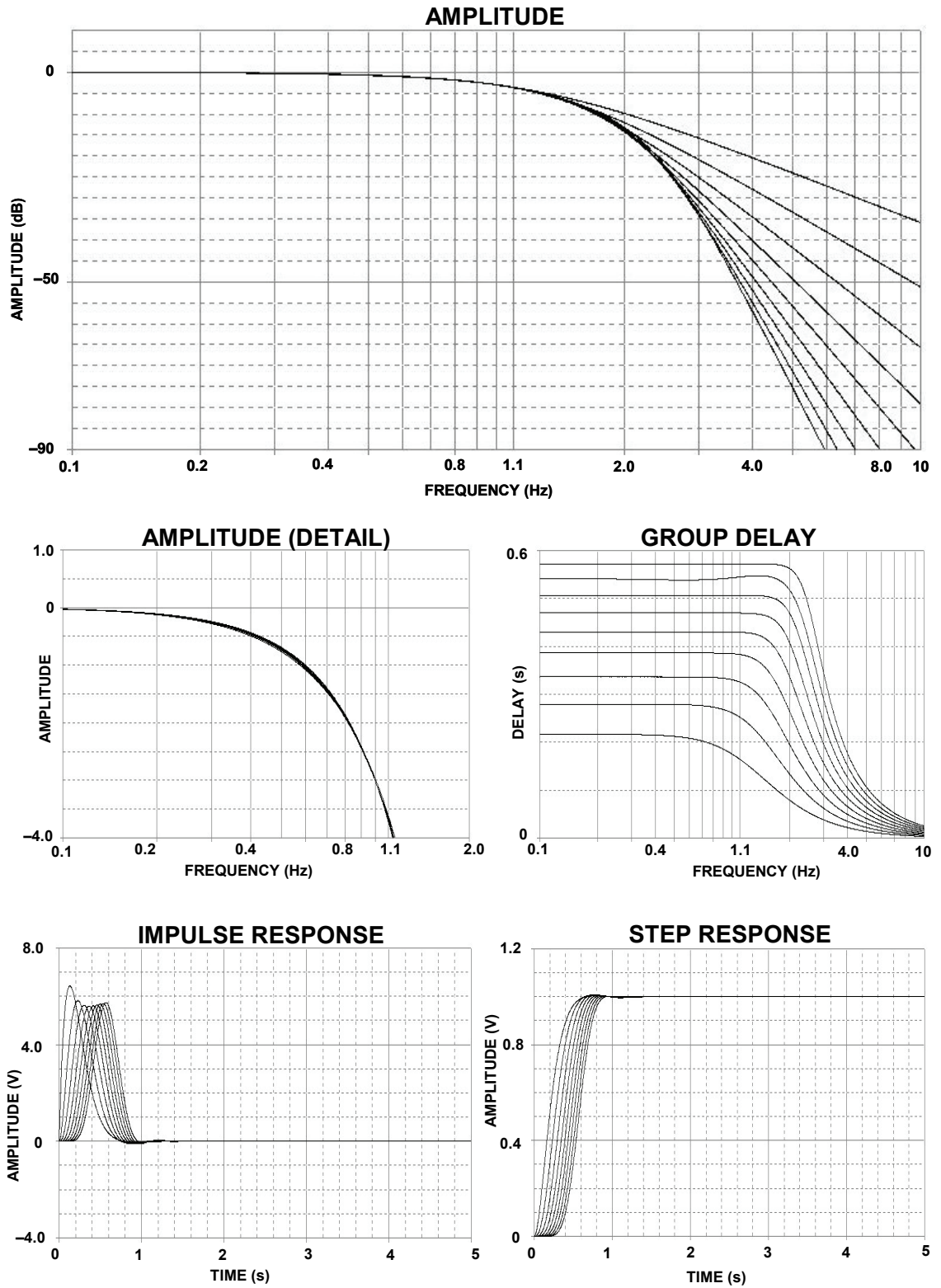

Figure 8.21: Bessel Response

## ▣ BASIC LINEAR DESIGN

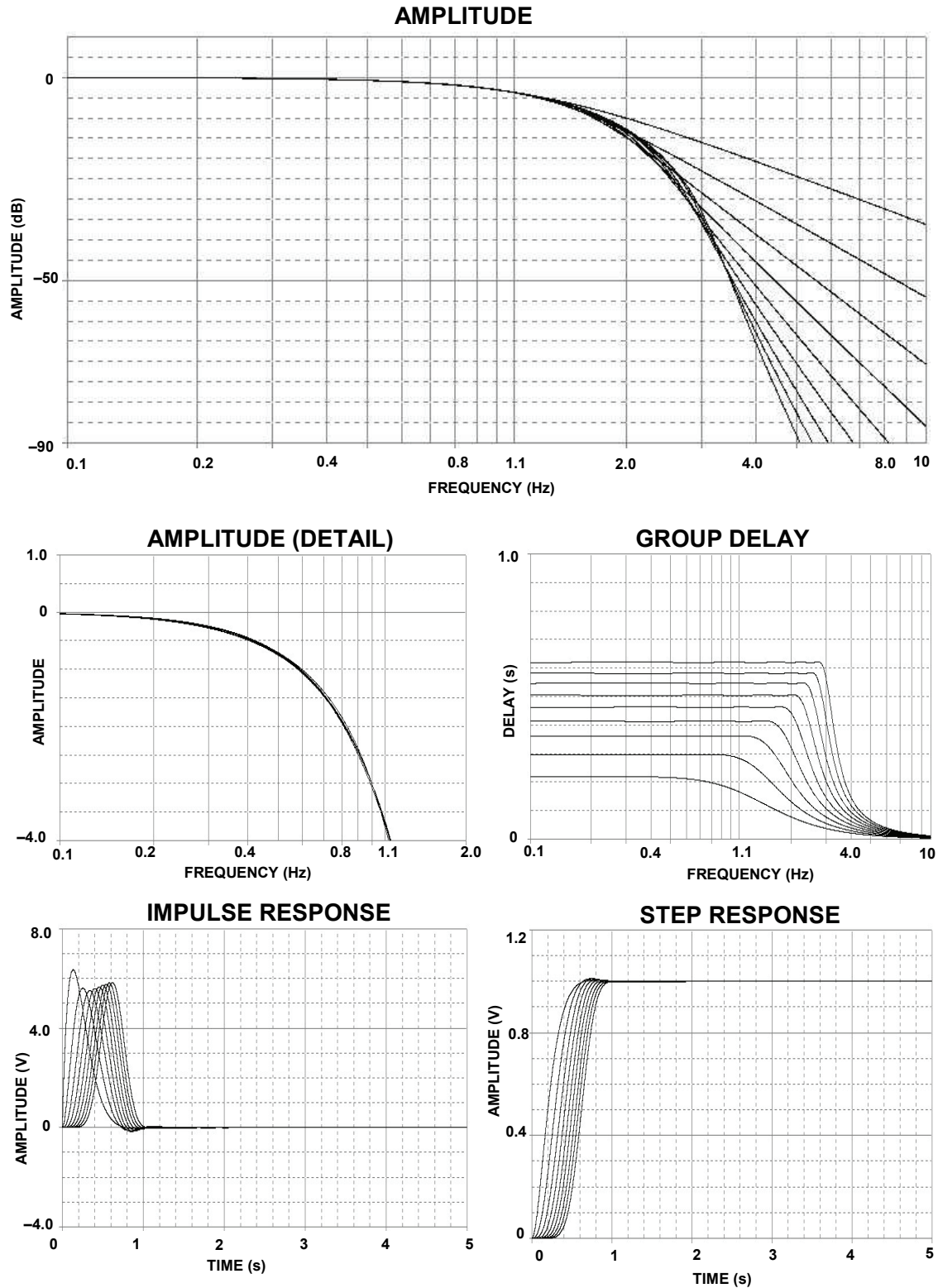

Figure 8.22: Linear Phase Response with Equiripple Error of  $0.05^\circ$

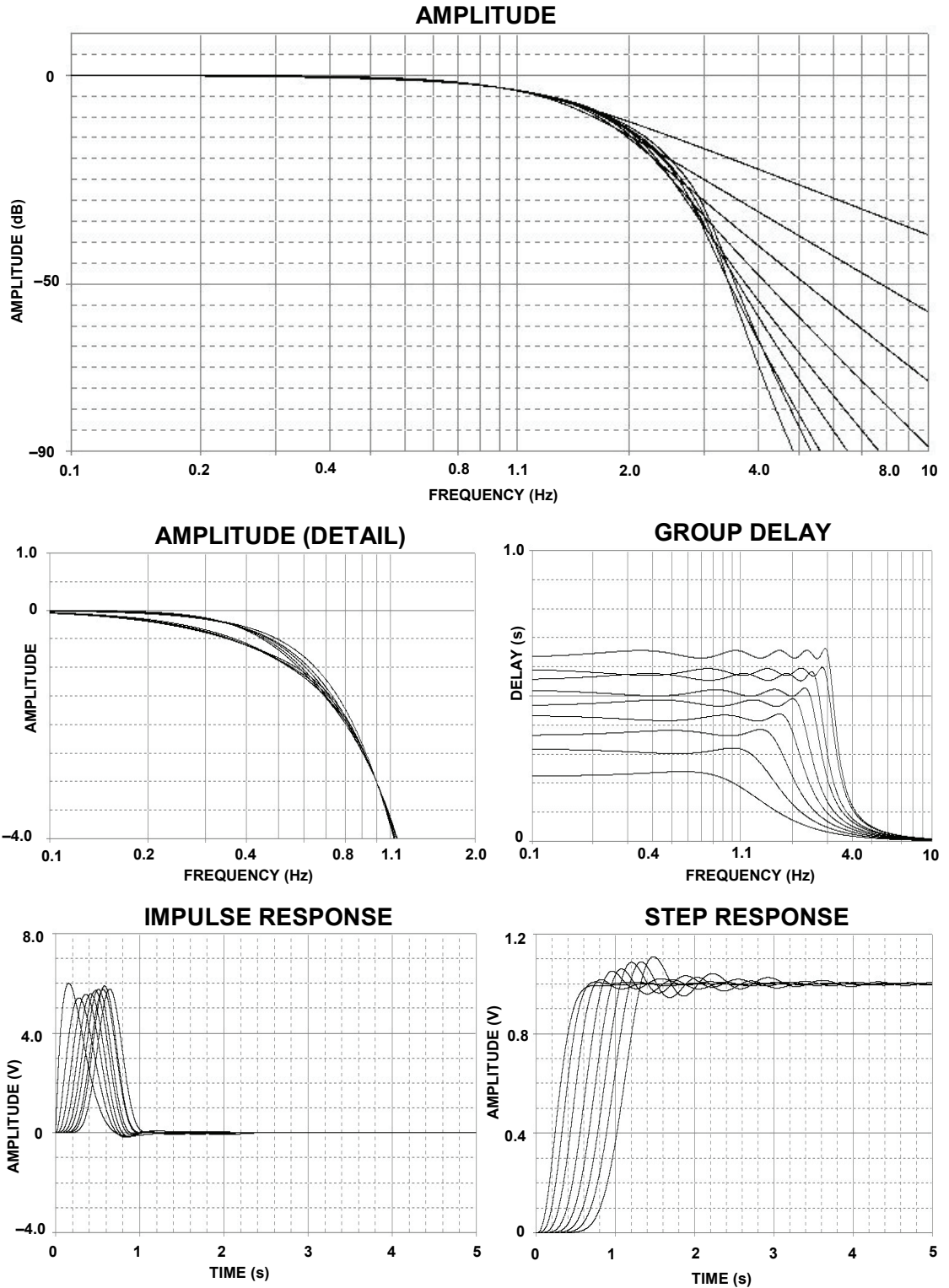
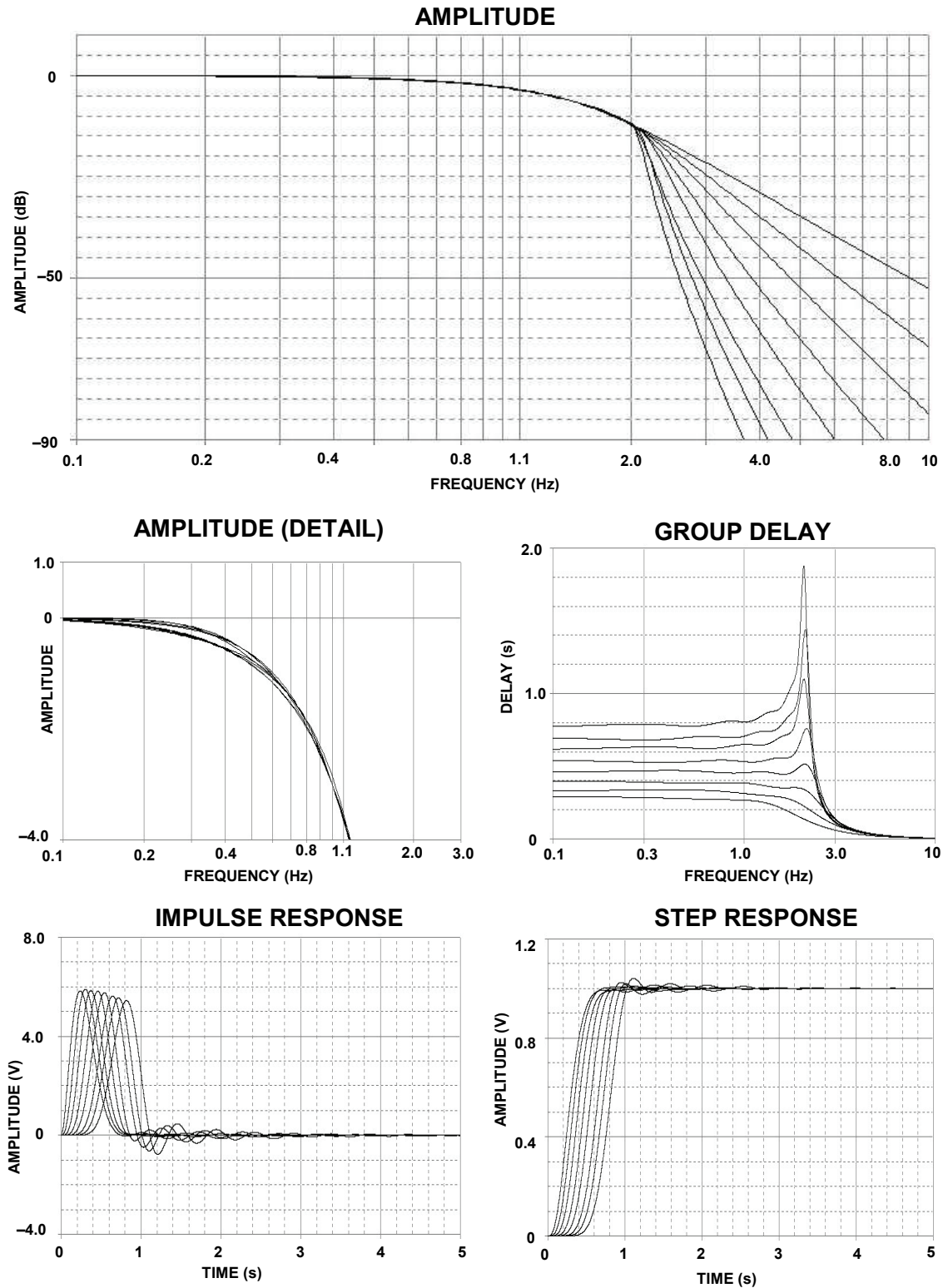

Figure 8.23: Linear Phase Response with Equiripple Error of  $0.5^\circ$

## ▣ BASIC LINEAR DESIGN



*Figure 8.24: Gaussian to 12 dB Response*



ANALOG FILTERS  
STANDARD RESPONSES

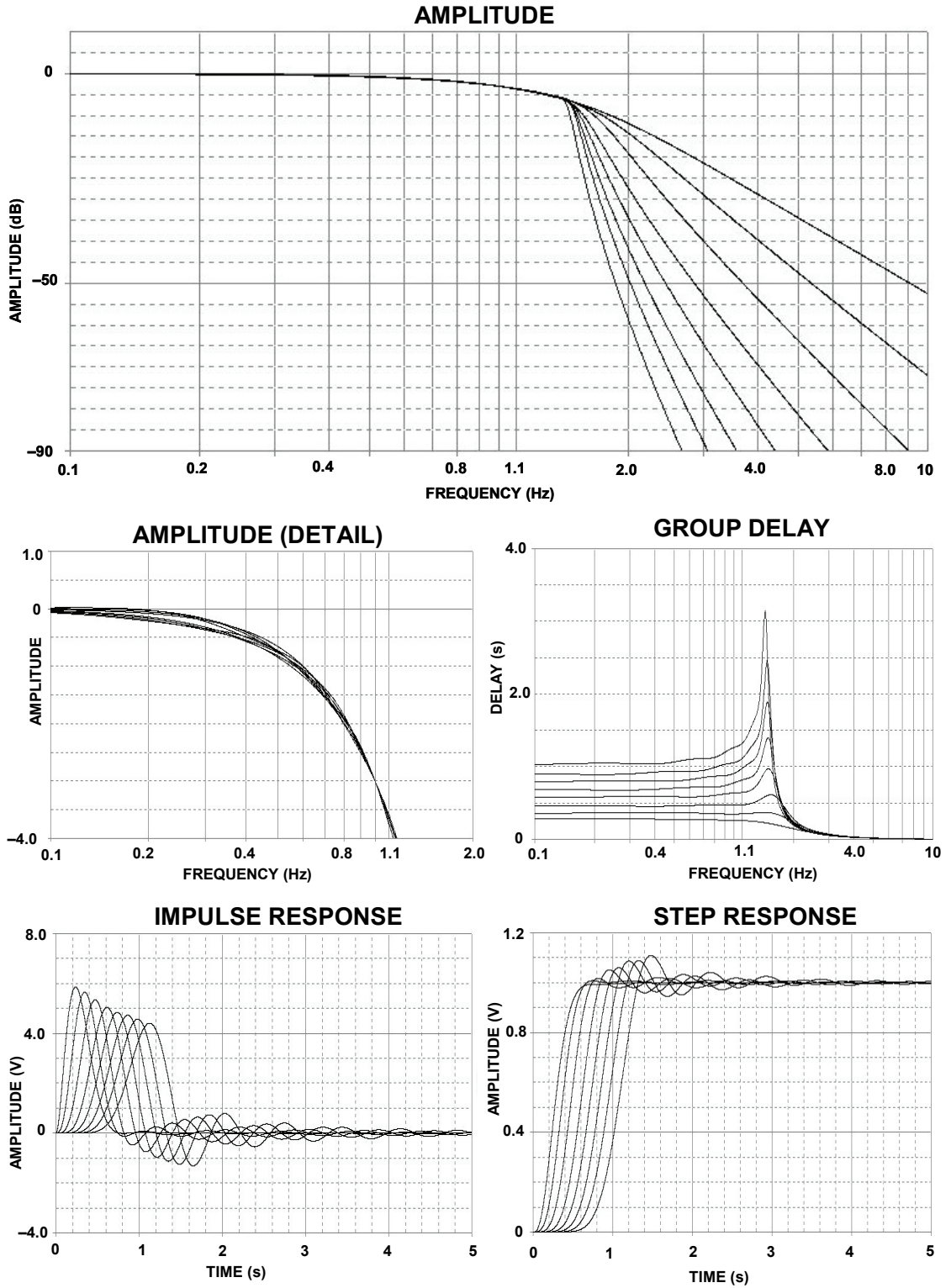

Figure 8.25: Gaussian to 6 dB Response

▣ BASIC LINEAR DESIGN

ORDER SECTION	REAL PART		IMAGINARY PART		F <sub>0</sub>	α	Q	-3 dB FREQUENCY	PEAKING FREQUENCY	PEAKING LEVEL
	PART	PART	PART	PART						
2	1	0.7071	0.7071		1.0000	1.4142	0.7071	1.0000		
3	1	0.5000	0.8660		1.0000	1.0000	1.0000	1.0000	0.7071	1.2493
	2	1.0000			1.0000					
4	1	0.9239	0.3827		1.0000	1.8478	0.5412	0.7195		
	2	0.3827	0.9239		1.0000	0.7654	1.3065		0.8409	3.0102
5	1	0.8090	0.5878		1.0000	1.6180	0.6180	0.8588		
	2	0.3090	0.9511		1.0000	0.6180	1.6182		0.8995	4.6163
	3	1.0000			1.0000			1.0000		
6	1	0.9659	0.2588		1.0000	1.9319	0.5176	0.6758		
	2	0.7071	0.7071		1.0000	1.4142	0.7071	1.0000		
	3	0.2588	0.9659		1.0000	0.5176	1.9319		0.9306	6.0210
7	1	0.9010	0.4339		1.0000	1.8019	0.5550	0.7449		
	2	0.6236	0.7818		1.0000	1.2470	0.8019		0.4717	0.2204
	3	0.2225	0.9749		1.0000	0.4450	2.2471		0.9492	7.2530
	4	1.0000			1.0000			1.0000		
8	1	0.9808	0.1951		1.0000	1.9616	0.5098	0.6615		
	2	0.8315	0.5556		1.0000	1.6629	0.6013	0.8295		
	3	0.5556	0.8315		1.0000	1.1112	0.9000		0.6186	0.6876
	4	0.1951	0.9808		1.0000	0.3902	2.5628		0.9612	8.3429
9	1	0.9397	0.3420		1.0000	1.8794	0.5321	0.7026		
	2	0.7660	0.6428		1.0000	1.5320	0.6527	0.9172		
	3	0.5000	0.8660		1.0000	1.0000	1.0000		0.7071	1.2493
	4	0.1737	0.9848		1.0000	0.3474	2.8785		0.9694	9.3165
	5	1.0000			1.0000			1.0000		
10	1	0.9877	0.1564		1.0000	1.9754	0.5062	0.6549		
	2	0.8910	0.4540		1.0000	1.7820	0.5612	0.7564		
	3	0.7071	0.7071		1.0000	1.4142	0.7071	1.0000		
	4	0.4540	0.8910		1.0000	0.9080	1.1013		0.7667	1.8407
	5	0.1564	0.9877		1.0000	0.3128	3.1970		0.9752	10.2023

Figure 8.26: Butterworth Design Table

**ANALOG FILTERS  
STANDARD RESPONSES**

ORDER	SECTION	REAL PART		IMAGINARY PART		F <sub>0</sub>	α	Q	-3 dB FREQUENCY	PEAKING FREQUENCY	PEAKING LEVEL
		PART	PART	PART	PART						
2	1	0.6743	0.7075	0.9774	1.3798	0.7247		0.2142		0.0100	
3	1	0.4233	0.8663	0.9642	0.8780	1.1389		0.7558		2.0595	
	2	0.8467		0.8467				0.8467			
4	1	0.6762	0.3828	0.7770	1.7405	0.5746		0.6069		5.1110	
	2	0.2801	0.9241	0.9656	0.5801	1.7237			0.8806		
5	1	0.5120	0.5879	0.7796	1.3135	0.7613			0.2889	0.0827	
	2	0.1956	0.9512	0.9711	0.4028	2.4824		0.6328	0.9309	8.0772	
	3	0.6328		0.6328							
6	1	0.5335	0.2588	0.5930	1.7995	0.5557		0.4425			
	2	0.3906	0.7072	0.8079	0.9670	1.0342			0.5895	1.4482	
	3	0.1430	0.9660	0.9765	0.2929	3.4144			0.9554	10.7605	
7	1	0.4393	0.4339	0.6175	1.4229	0.7028		0.6136			
	2	0.3040	0.7819	0.8389	0.7247	1.3798			0.7204	3.4077	
	3	0.1085	0.9750	0.9810	0.2212	4.5208			0.9689	13.1578	
	4	0.4876		0.4876				0.4876			
8	1	0.4268	0.1951	0.4693	1.8190	0.5498		0.3451			
	2	0.3168	0.5556	0.6396	0.9907	1.0094			0.4564	1.3041	
	3	0.2418	0.8315	0.8659	0.5585	1.7906			0.7956	5.4126	
	4	0.0849	0.9808	0.9845	0.1725	5.7978			0.9771	15.2977	
9	1	0.3686	0.3420	0.5028	1.4661	0.6821		0.4844			
	2	0.3005	0.5428	0.7096	0.8470	1.1807			0.5682	2.3008	
	3	0.1961	0.8661	0.8880	0.4417	2.2642			0.8436	7.3155	
	4	0.0681	0.9848	0.9872	0.1380	7.2478			0.9824	17.2249	
	5	0.3923		0.3923				0.3923			
10	1	0.3522	0.1564	0.3654	1.8279	0.5471		0.2814			
	2	0.3178	0.454	0.5542	1.1469	0.8719			0.3242	0.5412	
	3	0.2522	0.7071	0.7507	0.6719	1.4884			0.6606	3.9742	
	4	0.1619	0.891	0.9056	0.3576	2.7968			0.8762	9.0742	
	5	0.0558	0.9877	0.9893	0.1128	8.8645			0.9861	18.9669	

**Figure 8.27: 0.01 dB Chebyshev Design Table**

▣ BASIC LINEAR DESIGN

ORDER	SECTION	REAL PART	IMAGINARY PART	F <sub>0</sub>	α	Q	-3 dB FREQUENCY	PEAKING FREQUENCY	PEAKING LEVEL
2	1	0.6104	0.7106	0.9368	1.3032	0.7673		0.3638	0.0999
3	1	0.3490	0.8684	0.9359	0.7458	1.3408		0.7952	3.1978
	2	0.6970		0.6970			0.6970		
4	1	0.2177	0.9254	0.9507	0.4580	2.1834		0.8994	7.0167
	2	0.5257	0.3833	0.6506	1.6160	0.6188	0.5596		
5	1	0.3842	0.5884	0.7027	1.0935	0.9145		0.4457	0.7662
	2	0.1468	0.9521	0.9634	0.3048	3.2812		0.9407	10.4226
	3	0.4749		0.4749			0.4749		
6	1	0.3916	0.2590	0.4695	1.6682	0.5995	0.3879		
	2	0.2867	0.7077	0.7636	0.7509	1.3316		0.6470	3.1478
	3	0.1049	0.9667	0.9724	0.2158	4.6348		0.9610	13.3714
7	1	0.3178	0.4341	0.5380	1.1814	0.8464		0.2957	0.4157
	2	0.2200	0.7823	0.8126	0.5414	1.8469		0.7507	5.6595
	3	0.0785	0.9755	0.9787	0.1604	6.2335		0.9723	15.9226
	4	0.3528		0.3528			0.3528		
8	1	0.3058	0.1952	0.3628	1.6858	0.5932	0.2956		
	2	0.2529	0.5558	0.6106	0.8283	1.2073		0.4949	2.4532
	3	0.1732	0.8319	0.8497	0.4077	2.4531		0.8137	7.9784
	4	0.0608	0.9812	0.9831	0.1237	8.0819		0.9793	18.1669
9	1	0.2622	0.3421	0.4310	1.2166	0.8219		0.2197	0.3037
	2	0.2137	0.6430	0.6776	0.6308	1.5854		0.6064	4.4576
	3	0.1395	0.8663	0.8775	0.3180	3.1450		0.8550	10.0636
	4	0.0485	0.9852	0.9864	0.0982	10.1795		0.9840	20.1650
	5	0.2790		0.2790			0.2790		
10	1	0.2493	0.1564	0.2943	1.6942	0.5902	0.2382		
	2	0.2249	0.4541	0.5067	0.8876	1.1266		0.3945	1.9880
	3	0.1785	0.7073	0.7295	0.4894	2.0434		0.6844	6.4750
	4	0.1146	0.8913	0.8986	0.2551	3.9208		0.8839	11.9386
	5	0.0395	0.9880	0.9888	0.0799	12.5163		0.9872	21.9565

Figure 8.28: 0.1 dB Chebyshev Design Table



**ANALOG FILTERS  
STANDARD RESPONSES**

ORDER	SECTION	REAL		IMAGINARY		F <sub>0</sub>	α	Q	-3 dB		PEAKING	
		PART	PART	PART	PART				FREQUENCY	FREQUENCY	FREQUENCY	LEVEL
2	1	0.5621	0.7154			0.9098	1.2356	0.8093			0.4425	0.2502
3	1	0.3062	0.8712			0.9234	0.6632	1.5079			0.8156	4.0734
	2	0.6124				0.6124			0.6124			
4	1	0.4501	0.3840			0.5916	1.5215	0.6572		0.5470		
	2	0.1865	0.9272			0.9458	0.3944	2.5356			0.9082	8.2538
5	1	0.3247	0.5892			0.6727	0.9653	1.0359			0.4917	1.4585
	2	0.1240	0.9533			0.9613	0.2580	3.8763			0.9452	11.8413
	3	0.4013				0.4013			0.4013			
6	1	0.3284	0.2593			0.4184	1.5697	0.6371		0.3730		
	2	0.2404	0.7083			0.7480	0.6428	1.5557			0.6663	4.3121
	3	0.0880	0.9675			0.9715	0.1811	5.205			0.9635	14.8753
7	1	0.2652	0.4344			0.5090	1.0421	0.9596			0.3441	1.0173
	2	0.1835	0.7828			0.8040	0.4565	2.1908			0.7610	7.0443
	3	0.0655	0.9761			0.9783	0.1339	7.4679			0.9739	17.4835
	4	0.2944				0.2944			0.2944			
8	1	0.2543	0.1953			0.3206	1.5862	0.6304		0.2822		
	2	0.2156	0.5561			0.5964	0.7230	1.3832			0.5126	3.4258
	3	0.1441	0.8323			0.8447	0.3412	2.9309			0.8197	9.4683
	4	0.0506	0.9817			0.9830	0.1029	9.7173			0.9804	19.7624
9	1	0.2176	0.3423			0.4056	1.0730	0.9320			0.2642	0.8624
	2	0.1774	0.6433			0.6673	0.5317	1.8808			0.6184	5.8052
	3	0.1158	0.8667			0.8744	0.2649	3.7755			0.8589	11.6163
	4	0.0402	0.9856			0.9864	0.0815	12.2659			0.9848	21.7812
	5	0.2315				0.2315			0.2315			
10	1	0.2065	0.1565			0.2591	1.5940	0.6274		0.2267		
	2	0.1863	0.4543			0.4910	0.7588	1.3178			0.4143	3.0721
	3	0.1478	0.7075			0.7228	0.4090	2.4451			0.6919	7.9515
	4	0.0949	0.8915			0.8965	0.2117	4.7236			0.8884	13.5344
	5	0.0327	0.9883			0.9888	0.0661	15.1199			0.9878	23.5957

**Figure 8.29: 0.25 dB Chebyshev Design Table**

▣ BASIC LINEAR DESIGN

ORDER	SECTION	REAL PART		IMAGINARY PART		F <sub>0</sub>	α	Q	-3 dB		PEAKING	
		PART	PART	PART	PART				FREQUENCY	FREQUENCY	FREQUENCY	LEVEL
2	1	0.5129	0.7225	1.2314	1.1577	0.8638				0.7072		0.5002
3	1	0.2683	0.8753	1.0688	0.5861	1.7061				0.9727		5.0301
	2	0.5366		0.6265					0.6265			
4	1	0.3872	0.3850	0.5969	1.4182	0.7051			0.5951			9.4918
	2	0.1605	0.9297	1.0313	0.3402	2.9391				1.0010		
5	1	0.2767	0.5902	0.6905	0.8490	1.1779					0.5522	2.2849
	2	0.1057	0.9550	1.0178	0.2200	4.5451				1.0054		13.2037
	3	0.3420		0.3623					0.3623			
6	1	0.2784	0.2596	0.3963	1.4627	0.6836			0.3827			
	2	0.2037	0.7091	0.7680	0.5522	1.8109				0.7071		5.5025
	3	0.0746	0.9687	1.0114	0.1536	6.5119				1.0055		16.2998
7	1	0.2241	0.4349	0.5040	0.9161	1.0916					0.3839	1.7838
	2	0.1550	0.7836	0.8228	0.3881	2.5767				0.7912		8.3880
	3	0.0553	0.9771	1.0081	0.1130	8.8487				1.0049		18.9515
	4	0.2487		0.2562					0.2562			
8	1	0.2144	0.1955	0.2968	1.4779	0.6767			0.2835			
	2	0.1817	0.5565	0.5989	0.6208	1.6109				0.5381		4.5815
	3	0.1214	0.8328	0.8610	0.2885	3.4662				0.8429		10.8885
	4	0.0426	0.9824	1.0060	0.0867	11.5305				1.0041		21.2452
9	1	0.1831	0.3425	0.3954	0.9429	1.0605					0.2947	1.6023
	2	0.1493	0.6436	0.6727	0.4520	2.2126				0.6374		7.1258
	3	0.0974	0.8671	0.8884	0.2233	4.4779				0.8773		13.0759
	4	0.0338	0.9861	1.0046	0.0686	14.5829				1.0034		23.2820
	5	0.1949		0.1984					0.1984			
10	1	0.1736	0.1566	0.2338	1.4851	0.6734			0.2221			
	2	0.1566	0.4545	0.4807	0.6515	1.5349				0.4267		4.2087
	3	0.1243	0.7078	0.7186	0.3459	2.8907				0.6968		9.3520
	4	0.0798	0.8919	0.8955	0.1782	5.6107				0.8883		15.0149
	5	0.0275	0.9887	0.9891	0.0556	17.9833				0.9883		25.1008

Figure 8.30: 0.5 dB Chebyshev Design Table

**ANALOG FILTERS  
STANDARD RESPONSES**

ORDER	SECTION	REAL PART		IMAGINARY PART		F <sub>0</sub>	α	Q	-3 dB		PEAKING LEVEL
		REAL PART	IMAGINARY PART	FREQUENCY	FREQUENCY						
2	1	0.4508	0.7351	0.8623	1.0456	0.9564			0.5806	0.9595	
3	1	0.2257	0.8822	0.9106	0.4957	2.0173			0.8528	6.3708	
	2	0.4513		0.4513				0.4513			
4	1	0.3199	0.3888	0.5019	1.2746	0.7845			0.2174	0.1557	
	2	0.1325	0.9339	0.9433	0.2809	3.5594			0.9245	11.1142	
5	1	0.2265	0.5918	0.6337	0.7149	1.3988			0.5467	3.5089	
	2	0.0865	0.9575	0.9614	0.1800	5.5559			0.9536	14.9305	
	3	0.2800		0.2800				0.2800			
6	1	0.2268	0.2601	0.3451	1.3144	0.7608			0.1273	0.0813	
	2	0.1550	0.7106	0.7273	0.4262	2.3462			0.6935	7.6090	
	3	0.0608	0.9707	0.9726	0.1249	8.0036			0.9688	18.0827	
7	1	0.1819	0.4354	0.4719	0.7710	1.2971			0.3956	2.9579	
	2	0.1259	0.7846	0.7946	0.3169	3.1558			0.7744	10.0927	
	3	0.0449	0.9785	0.9795	0.0918	10.8982			0.9775	20.7563	
	4	0.2019		0.2019				0.2019			
8	1	0.1737	0.1956	0.2616	1.3280	0.7530			0.0899	0.0611	
	2	0.1473	0.5571	0.5762	0.5112	1.9560			0.5373	6.1210	
	3	0.0984	0.8337	0.8395	0.2344	4.2657			0.8279	12.6599	
	4	0.0346	0.9836	0.9842	0.0702	14.2391			0.9830	23.0750	
9	1	0.1482	0.3427	0.3734	0.7938	1.2597			0.3090	2.7498	
	2	0.1208	0.6442	0.6554	0.3686	2.7129			0.6328	8.8187	
	3	0.0788	0.8679	0.8715	0.1809	5.5268			0.8643	14.8852	
	4	0.0274	0.9869	0.9873	0.0555	18.0226			0.9865	25.1197	
	5	0.1577		0.1577				0.1577			
10	1	0.1403	0.1567	0.2103	1.3341	0.7496			0.0698	0.0530	
	2	0.1266	0.4548	0.4721	0.5363	1.8645			0.4368	5.7354	
	3	0.1005	0.7084	0.7155	0.2809	3.5597			0.7012	11.1147	
	4	0.0645	0.8926	0.8949	0.1441	6.9374			0.8903	16.8466	
	5	0.0222	0.9895	0.9897	0.0449	22.2916			0.9893	26.9650	

**Figure 8.31: 1 dB Chebyshev Design Table**

▣ BASIC LINEAR DESIGN

ORDER	SECTION	REAL PART		IMAGINARY PART		F <sub>0</sub>	α	Q	-3 dB FREQUENCY		PEAKING FREQUENCY		PEAKING LEVEL	
2	1	1.1050	0.6368			1.2754	1.7328	0.5771	1.0020					
3	1	1.0509	1.0025			1.4524	1.4471	0.6910	1.4185					
	2	1.3270				1.3270			1.3270					
4	1	1.3596	0.4071			1.4192	1.9160	0.5219	0.9705					
	2	0.9877	1.2476			1.5912	1.2414	0.8055			0.7622			0.2349
5	1	1.3851	0.7201			1.5611	1.7745	0.5635	1.1876					
	2	0.9606	1.4756			1.7607	1.0911	0.9165			1.1201			0.7768
	3	1.5069				1.5069			1.5069					
6	1	1.5735	0.3213			1.6060	1.9596	0.5103	1.0638					
	2	1.3836	0.9727			1.6913	1.6361	0.6112	1.4323					
	3	0.9318	1.6640			1.9071	0.9772	1.0234			1.3786			1.3851
7	1	1.6130	0.5896			1.7174	1.8784	0.5324	1.2074					
	2	1.3797	1.1923			1.8235	1.5132	0.6608	1.6964					
	3	0.9104	1.8375			2.0507	0.8879	1.1262			1.5961			1.9860
	4	1.6853				1.6853			1.6853					
8	1	1.7627	0.2737			1.7838	1.9763	0.5060	1.1675					
	2	0.8955	2.0044			2.1953	0.8158	1.2258			1.7932			2.5585
	3	1.3780	1.3926			1.9591	1.4067	0.7109			0.2011			0.0005
	4	1.6419	0.8256			1.8378	1.7868	0.5597	1.3849					
9	1	1.8081	0.5126			1.8794	1.9242	0.5197	1.2774					
	2	1.6532	1.0319			1.9488	1.6966	0.5894	1.5747					
	3	1.3683	1.5685			2.0815	1.3148	0.7606			0.7668			0.0807
	4	0.8788	2.1509			2.3235	0.7564	1.3220			1.9632			3.0949
	5	1.8575				1.8575			1.8575					
10	1	1.9335	0.2451			1.9490	1.9841	0.5040	1.2685					
	2	1.8467	0.7335			1.9870	1.8587	0.5380	1.4177					
	3	1.6661	1.2246			2.0678	1.6115	0.6205	1.7848					
	4	1.3648	1.7395			2.2110	1.2346	0.8100			1.0785			0.2531
	5	0.8686	2.2994			2.4580	0.7067	1.4150			2.1291			3.5944

Figure 8.32: Bessel Design Table

**ANALOG FILTERS  
STANDARD RESPONSES**

ORDER	SECTION	REAL		IMAGINARY		F <sub>0</sub>	α	Q	-3 dB		PEAKING	
		PART	PART	PART	PART				FREQUENCY	FREQUENCY	FREQUENCY	LEVEL
2	1	1.0087	0.6680			1.2098	1.6675	0.5997	0.9999			
3	1	0.8541	1.0725			1.3710	1.2459	0.8026		0.6487		0.2232
	2	1.0459				1.0459			1.0459			
4	1	0.9648	0.4748			1.0753	1.7945	0.5573	0.8056			
	2	0.7448	1.4008			1.5865	0.9389	1.0650		1.1864		1.6286
5	1	0.8915	0.8733			1.2480	1.4287	0.6999	1.2351			
	2	0.6731	1.7085			1.8363	0.7331	1.3641		1.5703		3.3234
	3	0.9430				0.9430			0.9430			
6	1	0.8904	0.4111			0.9807	1.8158	0.5507	0.7229			
	2	0.8233	1.2179			1.4701	1.1201	0.8928		0.8975		0.6495
	3	0.6152	1.9810			2.0743	0.5932	1.6859		1.8831		4.9365
7	1	0.8425	0.7791			1.1475	1.4684	0.6810	1.1036			
	2	0.7708	1.5351			1.7177	0.8975	1.1143		1.3276		1.9162
	3	0.5727	2.2456			2.3175	0.4942	2.0233		2.1713		6.3948
	4	0.8615				0.8615			0.8615			
8	1	0.8195	0.3711			0.8996	1.8219	0.5489	0.6600			
	2	0.7930	1.1054			1.3604	1.1658	0.8578		0.7701		0.4705
	3	0.7213	1.8134			1.9516	0.7392	1.3528		1.6638		3.2627
	4	0.5341	2.4761			2.5330	0.4217	2.3713		2.4178		7.6973
9	1	0.7853	0.7125			1.0604	1.4812	0.6751	1.0102			
	2	0.7555	1.4127			1.6020	0.9432	1.0602		1.1937		1.6005
	3	0.6849	2.0854			2.1950	0.6241	1.6024		1.9697		4.5404
	4	0.5060	2.7133			2.7601	0.3667	2.7274		2.6657		8.8633
	5	0.7983				0.7983			0.7983			
10	1	0.7592	0.3413			0.8324	1.8241	0.5482	0.6096			
	2	0.7467	1.0195			1.2637	1.1818	0.8462		0.6941		0.4145
	3	0.7159	1.6836			1.8295	0.7826	1.2778		1.5238		2.8507
	4	0.6475	2.3198			2.4085	0.5377	1.8598		2.2276		5.7152
	5	0.4777	2.9128			2.9517	0.3237	3.0895		2.8734		9.9130

**Figure 8.33: Linear Phase with Equiripple Error of 0.05° Design Table**

▣ BASIC LINEAR DESIGN

ORDER	SECTION	REAL PART		IMAGINARY PART		F <sub>0</sub>	α	Q	-3 dB		PEAKING	
		PART	PART	PART	PART				FREQUENCY	FREQUENCY	FREQUENCY	LEVEL
2	1	0.8590	0.6981			1.1069	1.5521	0.6443	1.0000			
3	1	0.6969	1.1318			1.3292	1.0486	0.9536		0.8918		0.9836
	2	0.8257				0.8257			0.8257			
4	1	0.7448	0.5133			0.9045	1.6468	0.6072	0.7597			
	2	0.6037	1.4983			1.6154	0.7475	1.3379		1.3713		3.1817
5	1	0.6775	0.9401			1.1588	1.1693	0.8552			0.6518	0.4579
	2	0.5412	1.8256			1.9041	0.5684	1.7592		1.7435		5.2720
	3	0.7056				0.7056			0.7056			
6	1	0.6519	0.4374			0.7850	1.6608	0.6021	0.6522			
	2	0.6167	1.2963			1.4355	0.8592	1.1639		1.1402		2.2042
	3	0.4893	2.0982			2.1545	0.4542	2.2016		2.0404		7.0848
7	1	0.6190	0.8338			1.0385	1.1922	0.8388			0.5586	0.3798
	2	0.5816	1.6455			1.7453	0.6665	1.5004		1.5393		4.0353
	3	0.4598	2.3994			2.4431	0.3764	2.6567		2.3549		8.6433
	4	0.6283				0.6283			0.6283			
8	1	0.5791	0.3857			0.6958	1.6646	0.6007	0.5764			
	2	0.5665	1.1505			1.2824	0.8835	1.1319		1.0014		2.0187
	3	0.5303	1.8914			1.9643	0.5399	1.8521		1.8155		5.6819
	4	0.4148	2.5780			2.6112	0.3177	3.1475		2.5444		10.0703
9	1	0.5688	0.7595			0.9489	1.1989	0.8341			0.5033	0.3581
	2	0.5545	1.5089			1.6076	0.6899	1.4496		1.4033		3.7748
	3	0.5179	2.2329			2.2922	0.4519	2.2130		2.1720		7.1270
	4	0.4080	2.9028			2.9313	0.2784	3.5923		2.8740		11.1925
	5	0.5728				0.5728			0.5728			
10	1	0.5249	0.3487			0.6302	1.6659	0.6003	0.5215			
	2	0.5193	1.0429			1.1650	0.8915	1.1217		0.9044		1.9598
	3	0.5051	1.7264			1.7988	0.5616	1.7806		1.6509		5.3681
	4	0.4711	2.3850			2.4311	0.3876	2.5802		2.3380		8.3994
	5	0.3708	2.9940			3.0169	0.2458	4.0681		2.9709		12.2539

Figure 8.34: Linear Phase with Equiripple Error of 0.5° Design Table

**ANALOG FILTERS  
STANDARD RESPONSES**

ORDER	SECTION	REAL PART	IMAGINARY PART	F <sub>0</sub>	α	Q	-3 dB FREQUENCY	PEAKING FREQUENCY	PEAKING LEVEL
3	1	0.9360	1.2168	1.5352	1.2194	0.8201		0.7775	0.2956
	2	0.9360		0.9360			0.9360		
4	1	0.9278	1.6995	1.9363	0.9583	1.0435		1.4239	1.5025
	2	0.9192	0.5560	1.0743	1.7113	0.5844	0.8582		
5	1	0.8075	0.9973	1.2832	1.2585	0.7946		0.5853	0.1921
	2	0.7153	0.2053	0.7442	1.9224	0.5202	0.5065		
	3	0.8131		0.8131			0.8131		
6	1	0.7019	0.4322	0.8243	1.7030	0.5872	0.6627		
	2	0.6667	1.2931	1.4549	0.9165	1.0911		1.1080	1.7809
	3	0.4479	2.1363	2.1827	0.4104	2.4366		2.0888	7.9227
7	1	0.6155	0.7703	0.9860	1.2485	0.8010		0.4632	0.2168
	2	0.5486	1.5154	1.6116	0.6808	1.4689		1.4126	3.8745
	3	0.2905	2.1486	2.1681	0.2680	3.7318		2.1289	11.5169
	4	0.6291		0.6291			0.6291		
8	1	0.5441	0.3358	0.6394	1.7020	0.5876	0.5145		
	2	0.5175	0.9962	1.1226	0.9220	1.0846		0.8512	1.7432
	3	0.4328	1.6100	1.6672	0.5192	1.9260		1.5507	5.9962
	4	0.1978	2.0703	2.0797	0.1902	5.2571		2.0608	14.4545
9	1	0.4961	0.6192	0.7934	1.2505	0.7997		0.3705	0.2116
	2	0.4568	1.2145	1.2976	0.7041	1.4203		1.1253	3.6221
	3	0.3592	1.7429	1.7795	0.4037	2.4771		1.7055	8.0594
	4	0.1489	2.1003	2.1056	0.1414	7.0704		2.0950	17.0107
	5	0.5065		0.5065			0.5065		
10	1	0.4535	0.2794	0.5327	1.7028	0.5873	0.4283		
	2	0.4352	0.8289	0.9362	0.9297	1.0756		0.7055	1.6904
	3	0.3886	1.3448	1.3998	0.5552	1.8011		1.2874	5.4591
	4	0.2908	1.7837	1.8072	0.3218	3.1074		1.7598	9.9618
	5	0.1136	2.0599	2.0630	0.1101	9.0802		2.0568	19.1751

**Figure 8.35: Gaussian to 12 dB Design Table**

▣ BASIC LINEAR DESIGN

ORDER	SECTION	REAL		IMAGINARY		F <sub>0</sub>	α	Q	-3 dB		PEAKING	
		PART	PART	PART	PART				FREQUENCY	FREQUENCY	FREQUENCY	LEVEL
3	1	0.9622	1.2214	1.5549	1.2377	0.8080				0.7523		0.2448
	2	0.9776	0.5029	1.0994	1.7785	0.5623			0.8338			
4	1	0.7940	0.5029	0.9399	1.6896	0.5919			0.7636			
	2	0.6304	1.5407	1.6647	0.7574	1.3203				1.4058		3.0859
5	1	0.6190	0.8254	1.0317	1.1999	0.8334					0.5460	0.3548
	2	0.3559	1.5688	1.6087	0.4425	2.2600				1.5279		7.3001
	3	0.6650		0.6650					0.6650			
6	1	0.5433	0.3431	0.6426	1.6910	0.5914			0.5215			
	2	0.4672	0.9991	1.1029	0.8472	1.1804				0.8831		2.2992
	3	0.2204	1.5067	1.5227	0.2895	3.4545				1.4905		10.8596
7	1	0.4580	0.5932	0.7494	1.2223	0.8182					0.3770	0.2874
	2	0.3649	1.1286	1.1861	0.6153	1.6253				1.0680		4.6503
	3	0.1522	1.4938	1.5015	0.2027	4.9328				1.4860		13.9067
	4	0.4828		0.4828					0.4828			
8	1	0.4222	0.2640	0.4979	1.6958	0.5897			0.4026			
	2	0.3833	0.7716	0.8616	0.8898	1.1239				0.6697		1.9722
	3	0.2678	1.2066	1.2360	0.4333	2.3076				1.1765		7.4721
	4	0.1122	1.4798	1.4840	0.1512	6.6134				1.4755		16.4334
9	1	0.3700	0.4704	0.5985	1.2365	0.8088					0.2905	0.2480
	2	0.3230	0.9068	0.9626	0.6711	1.4901				0.8473		3.9831
	3	0.2309	1.2634	1.2843	0.3596	2.7811				1.2421		9.0271
	4	0.0860	1.4740	1.4765	0.1165	8.5804				1.4715		18.6849
	5	0.3842		0.3842					0.3842			
10	1	0.3384	0.2101	0.3983	1.6991	0.5885			0.3212			
	2	0.3164	0.6180	0.6943	0.9114	1.0972				0.5309		1.8164
	3	0.2677	0.9852	1.0209	0.5244	1.9068				0.9481		5.9157
	4	0.1849	1.2745	1.2878	0.2871	3.4825				1.2610		10.9284
	5	0.0671	1.4389	1.4405	0.0931	10.7401				1.4373		20.6296

Figure 8.36: Gaussian to 6 dB Design Table



***Notes:***

## ▣ BASIC LINEAR DESIGN

*Notes:*

## SECTION 8.5: FREQUENCY TRANSFORMATIONS

Until now, only filters using the low-pass configuration have been examined. In this section, transforming the low-pass prototype into the other configurations: high-pass, band-pass, band-reject (notch) and all-pass will be discussed .

### Low-Pass to High-Pass

The low-pass prototype is converted to high-pass filter by scaling by  $1/s$  in the transfer function. In practice, this amounts to capacitors becoming inductors with a value  $1/C$ , and inductors becoming capacitors with a value of  $1/L$  for passive designs. For active designs, resistors become capacitors with a value of  $1/R$ , and capacitors become resistors with a value of  $1/C$ . This applies only to frequency setting resistor, not those only used to set gain.

Another way to look at the transformation is to investigate the transformation in the  $s$  plane. The complex pole pairs of the low-pass prototype are made up of a real part,  $\alpha$ , and an imaginary part,  $\beta$ . The normalized high-pass poles are the given by:

$$\alpha_{\text{HP}} = \frac{\alpha}{\alpha^2 + \beta^2} \quad \text{Eq. 8-46}$$

and:

$$\beta_{\text{HP}} = \frac{\beta}{\alpha^2 + \beta^2} \quad \text{Eq. 8-47}$$

A simple pole,  $\alpha_0$ , is transformed to:

$$\alpha_{\omega, \text{HP}} = \frac{1}{\alpha_0} \quad \text{Eq. 8-48}$$

Low-pass zeros,  $\omega_{z, \text{lp}}$ , are transformed by:

$$\omega_{z, \text{HP}} = \frac{1}{\omega_{z, \text{LP}}} \quad \text{Eq. 8-49}$$

In addition, a number of zeros equal to the number of poles are added at the origin.

After the normalized low-pass prototype poles and zeros are converted to high-pass, they are then denormalized in the same way as the low-pass, that is, by frequency and impedance.

As an example a 3 pole 1 dB Chebyshev low-pass filter will be converted to a high-pass filter.

## ▣ BASIC LINEAR DESIGN

From the design tables of the last section:

$$\begin{aligned}\alpha_{LP1} &= .2257 \\ \beta_{LP1} &= .8822 \\ \alpha_{LP2} &= .4513\end{aligned}$$

This will transform to:

$$\begin{aligned}\alpha_{HP1} &= .2722 \\ \beta_{HP1} &= 1.0639 \\ \alpha_{HP2} &= 2.2158\end{aligned}$$

Which then becomes:

$$\begin{aligned}F_{01} &= 1.0982 \\ \alpha &= .4958 \\ Q &= 2.0173\end{aligned}$$

$$F_{02} = 2.2158$$

A worked out example of this transformation will appear in a latter section.

A high-pass filter can be considered to be a low-pass filter turned on its side. Instead of a flat response at dc, there is a rising response of  $n \times (20 \text{ dB/decade})$ , due to the zeros at the origin, where  $n$  is the number of poles. At the corner frequency a response of  $n \times (-20 \text{ dB/decade})$  due to the poles is added to the above rising response. This results in a flat response beyond the corner frequency.

### Low-Pass to Band-Pass

Transformation to the band-pass response is a little more complicated. Band-pass filters can be classified as either wideband or narrow-band, depending on the separation of the poles. If the corner frequencies of the band-pass are widely separated (by more than 2 octaves), the filter is wideband and is made up of separate low-pass and high-pass sections, which will be cascaded. The assumption made is that with the widely separated poles, interaction between them is minimal. This condition does not hold in the case of a narrowband band-pass filter, where the separation is less than 2 octaves. We will be covering the narrow-band case in this discussion.

As in the highpass transformation, start with the complex pole pairs of the low-pass prototype,  $\alpha$  and  $\beta$ . The pole pairs are known to be complex conjugates. This implies symmetry around dc (0 Hz.). The process of transformation to the band-pass case is one of mirroring the response around dc of the low-pass prototype to the same response around the new center frequency  $F_0$ .

This clearly implies that the number of poles and zeros is doubled when the band-pass transformation is done. As in the low-pass case, the poles and zeros below the real axis are ignored. So an  $n^{\text{th}}$  order low-pass prototype transforms into an  $n^{\text{th}}$  order band-pass,

even though the filter order will be  $2n$ . An  $n^{\text{th}}$  order band-pass filter will consist of  $n$  sections, versus  $n/2$  sections for the low-pass prototype. It may be convenient to think of the response as  $n$  poles up and  $n$  poles down.

The value of  $Q_{\text{BP}}$  is determined by:

$$Q_{\text{BP}} = \frac{F_0}{\text{BW}} \quad \text{Eq. 8-50}$$

where BW is the bandwidth at some level, typically  $-3$  dB.

A transformation algorithm was defined by Geffe ( Reference 16) for converting low-pass poles into equivalent band-pass poles.

Given the pole locations of the low-pass prototype:

$$-\alpha \pm j\beta \quad \text{Eq. 8-51}$$

and the values of  $F_0$  and  $Q_{\text{BP}}$ , the following calculations will result in two sets of values for  $Q$  and frequencies,  $F_{\text{H}}$  and  $F_{\text{L}}$ , which define a pair of band-pass filter sections.

$$C = \alpha^2 + \beta^2 \quad \text{Eq. 8-52}$$

$$D = \frac{2\alpha}{Q_{\text{BP}}} \quad \text{Eq. 8-53}$$

$$E = \frac{C}{Q_{\text{BP}}^2} + 4 \quad \text{Eq. 8-54}$$

$$G = \sqrt{E^2 - 4 D^2} \quad \text{Eq. 8-55}$$

$$Q = \sqrt{\frac{E + G}{2 D^2}} \quad \text{Eq. 8-56}$$

Observe that the  $Q$  of each section will be the same.

The pole frequencies are determined by:

$$M = \frac{\alpha Q}{Q_{\text{BP}}} \quad \text{Eq. 8-57}$$

$$W = M + \sqrt{M^2 - 1} \quad \text{Eq. 8-58}$$

$$F_{\text{BP1}} = \frac{F_0}{W} \quad \text{Eq. 8-59}$$

$$F_{\text{BP2}} = W F_0 \quad \text{Eq. 8-60}$$

Each pole pair transformation will also result in 2 zeros that will be located at the origin.

A normalized low-pass real pole with a magnitude of  $\alpha_0$  is transformed into a band-pass section where:

$$Q = \frac{Q_{\text{BP}}}{\alpha_0} \quad \text{Eq. 8-61}$$

## ▣ BASIC LINEAR DESIGN

and the frequency is  $F_0$ .

Each single pole transformation will also result in a zero at the origin.

Elliptical function low-pass prototypes contain zeros as well as poles. In transforming the filter the zeros must be transformed as well. Given the low-pass zeros at  $\pm j\omega_z$ , the band-pass zeros are obtained as follows:

$$M = \frac{\alpha Q}{Q_{BP}} \quad \text{Eq. 8-62}$$

$$W = M + \sqrt{M^2 - 1} \quad \text{Eq. 8-63}$$

$$F_{BP1} = \frac{F_0}{W} \quad \text{Eq. 8-64}$$

$$F_{BP2} = W F_0 \quad \text{Eq. 8-65}$$

Since the gain of a band-pass filter peaks at  $F_{BP}$  instead of  $F_0$ , an adjustment in the amplitude function is required to normalize the response of the aggregate filter. The gain of the individual filter section is given by:

$$A_R = A_0 \sqrt{1 + Q^2 \left( \frac{F_0}{F_{BP}} - \frac{F_{BP}}{F_0} \right)^2} \quad \text{Eq. 8-66}$$

where:

$A_0$  = gain a filter center frequency

$A_R$  = filter section gain at resonance

$F_0$  = filter center frequency

$F_{BP}$  = filter section resonant frequency.

Again using a 3 pole 1 dB Chebychev as an example:

$$\alpha_{LP1} = .2257$$

$$\beta_{LP1} = .8822$$

$$\alpha_{LP2} = .4513$$

A 3 dB bandwidth of 0.5 Hz. with a center frequency of 1 Hz is arbitrarily assigned.

Then:

$$Q_{BP} = 2$$

Going through the calculations for the pole pair the intermediate results are:

$$\begin{array}{ll} C = 0.829217 & D = 0.2257 \\ E = 4.2073 & G = 4.18302 \\ M = 1.0247 & W = 1.245 \end{array}$$

and:

$$\begin{array}{ll} F_{BP1} = 0.80322 & F_{BP2} = 1.24499 \\ Q_{BP1} = Q_{BP2} = 9.0749 \end{array}$$

$$\text{Gain} = 4.1318$$

And for the single pole:

$$\begin{aligned} F_{BP3} &= 1 & Q_{BP3} &= 4.431642 \\ \text{Gain} &= 1 \end{aligned}$$

Again a full example will be worked out in a latter section.

### **Low-Pass to Band-reject (Notch)**

As in the band-pass case, a band-reject filter can be either wideband or narrow-band, depending on whether or not the poles are separated by 2 octaves or more. To avoid confusion, the following convention will be adopted. If the filter is wideband, it will be referred to as a band-reject filter. A narrow-band filter will be referred to as a notch filter.

One way to build a notch filter is to construct it as a band-pass filter whose output is subtracted from the input ( $1 - BP$ ). Another way is with cascaded low-pass and high-pass sections, especially for the band-reject (wideband) case. In this case, the sections are in parallel, and the output is the difference.

Just as the band-pass case is a direct transformation of the low-pass prototype, where dc is transformed to  $F_0$ , the notch filter can be first transformed to the high-pass case, and then dc, which is now a zero, is transformed to  $F_0$ .

A more general approach would be to convert the poles directly. A notch transformation results in two pairs of complex poles and a pair of second order imaginary zeros from each low-pass pole pair.

First, the value of  $Q_{BR}$  is determined by:

$$Q_{BR} = \frac{F_0}{BW} \quad \text{Eq. 8-67}$$

where  $BW$  is the bandwidth at  $-3\text{dB}$ .

Given the pole locations of the low-pass prototype

$$-\alpha \pm j\beta \quad \text{Eq. 8-68}$$

and the values of  $F_0$  and  $Q_{BR}$ , the following calculations will result in two sets of values for  $Q$  and frequencies,  $F_H$  and  $F_L$ , which define a pair of notch filter sections.

## ▣ BASIC LINEAR DESIGN

$$C = \alpha^2 + \beta^2 \quad \text{Eq. 8-69}$$

$$D = \frac{\alpha}{Q_{BR}C} \quad \text{Eq. 8-70}$$

$$E = \frac{\beta}{Q_{BR}C} \quad \text{Eq. 8-71}$$

$$F = E^2 - D^2 + 4 \quad \text{Eq. 8-72}$$

$$G = \sqrt{\frac{F}{2}} + \sqrt{\frac{F-2}{4}} + D^2 E^2 \quad \text{Eq. 8-73}$$

$$H = \frac{DE}{G} \quad \text{Eq. 8-74}$$

$$K = \frac{1}{2} \sqrt{(D+H)^2 + (E+G)^2} \quad \text{Eq. 8-75}$$

$$Q = \frac{K}{D+H} \quad \text{Eq. 8-76}$$

the pole frequencies are given by:

$$F_{BR1} = \frac{F_0}{K} \quad \text{Eq. 8-77}$$

$$F_{BR2} = K F_0 \quad \text{Eq. 8-78}$$

$$F_Z = F_0 \quad \text{Eq. 8-79}$$

$$F_0 = \sqrt{F_{BR1} * F_{BR2}} \quad \text{Eq. 8-80}$$

where  $F_0$  is the notch frequency and the geometric mean of  $F_{BR1}$  and  $F_{BR2}$ .

A simple real pole,  $\alpha_0$ , transforms to a single section having a Q given by:

$$Q = Q_{BR} \alpha_0 \quad \text{Eq. 8-81}$$

with a frequency  $F_{BR} = F_0$ . There will also be transmission zero at  $F_0$ .

In some instances, such as the elimination of the power line frequency (hum) from low level sensor measurements, a notch filter for a specific frequency may be designed.

Assuming that an attenuation of A dB is required over a bandwidth of B, then the required Q for a single frequency notch is determined by:

$$Q = \frac{\omega_0}{B \sqrt{10^{0.1A} - 1}} \quad \text{Eq. 8-82}$$



For transforming a low-pass prototype, a 3 pole 1 dB Chebychev is again used as an example:

$$\begin{aligned}\alpha_{LP1} &= .2257 \\ \beta_{LP1} &= .8822 \\ \alpha_{LP2} &= .4513\end{aligned}$$

A 3 dB bandwidth of 0.1 Hz with a center frequency of 1 Hz is arbitrarily assigned. Then:

$$Q_{BR} = 10$$

Going through the calculations for the pole pair yields the intermediate results:

$$\begin{aligned}C &= 0.829217 & D &= 0.027218 \\ E &= 0.106389 & F &= 4.01058 \\ G &= 2.002643 & H &= 0.001446 \\ K &= 1.054614\end{aligned}$$

and

$$\begin{aligned}F_{BR1} &= 0.94821 & F_{BR2} &= 1.0546 \\ Q_{BR1} &= Q_{BR2} &= 36.7918\end{aligned}$$

and for the single-pole

$$F_{BP3} = 1 \quad Q_{BP3} = 4.4513$$

Once again a full example will be worked out in a latter section.

### **Low-Pass to All-Pass**

The transformation from low-pass to all-pass involves adding a zero in the right hand side of the s plane corresponding to each pole in the left hand side.

In general, however, the all-pass filter is usually not designed in this manner. The main purpose of the all-pass filter is to equalize the delay of another filter. Many modulation schemes in communications use some form or another of quadrature modulation, which processes both the amplitude and phase of the signal.

All-pass filters add delay to flatten the delay curve without changing the amplitude. In most cases a closed form of the equalizer is not available. Instead the amplitude filter is designed and the delay calculated or measured. Then graphical means or computer programs are used to figure out the required sections of equalization.

## ▣ BASIC LINEAR DESIGN

Each section of the equalizer gives twice the delay of the low-pass prototype due to the interaction of the zeros. A rough estimate of the required number of sections is given by:

$$n = 2 \Delta_{\text{BW}} \Delta_{\text{T}} + 1 \qquad \text{Eq. 8-83}$$

Where  $\Delta_{\text{BW}}$  is the bandwidth of interest in hertz and  $\Delta_{\text{T}}$  is the delay distortion over  $\Delta_{\text{BW}}$  in seconds.

## SECTION 8.6: FILTER REALIZATIONS

Now that it has been decided what to build, it now must be decided how to build it. That means that it is necessary to decide which of the filter topologies to use. Filter design is a two step process where it is determined what is to be built (the filter transfer function) and then how to build it (the topology used for the circuit).

In general, filters are built out of one-pole sections for real poles, and two-pole sections for pole pairs. While you can build a filter out of three-pole, or higher order sections, the interaction between the sections increases, and therefore, component sensitivities go up.

It is better to use buffers to isolate the various sections. In addition, it is assumed that all filter sections are driven from a low impedance source. Any source impedance can be modeled as being in series with the filter input.

In all of the design equation figures the following convention will be used:

$H$  = circuit gain in the pass band or at resonance

$F_0$  = cutoff or resonant frequency in Hertz

$\omega_0$  = cutoff or resonant frequency in radians/sec.

$Q$  = circuit “quality factor”. Indicates circuit peaking.

$\alpha = 1/Q$  = damping ratio

It is unfortunate that the symbol  $\alpha$  is used for damping ratio. It is not the same as the  $\alpha$  that is used to denote pole locations ( $\alpha \pm j\beta$ ). The same issue occurs for  $Q$ . It is used for the *circuit* quality factor and also the *component* quality factor, which are not the same thing.

The circuit  $Q$  is the amount of peaking in the circuit. This is a function of the angle of the pole to the origin in the  $s$  plane. The component  $Q$  is the amount of losses in what should be lossless reactances. These losses are the parasitics of the components; dissipation factor, leakage resistance, ESR (equivalent series resistance), etc. in capacitors and series resistance and parasitic capacitances in inductors.

## ▣ BASIC LINEAR DESIGN

### Single-Pole RC

The simplest filter building block is the passive RC section. The single-pole can be either low-pass or high-pass. Odd order filters will have a single-pole section.

The basic form of the low-pass RC section is shown in Figure 8.37(A). It is assumed that the load impedance is high ( $> \times 10$ ), so that there is no loading of the circuit. The load will be in parallel with the shunt arm of the filter. If this is not the case, the section will have to be buffered with an op amp. A low-pass filter can be transformed to a high-pass filter by exchanging the resistor and the capacitor. The basic form of the high-pass filter is shown in Figure 8.37(B). Again it is assumed that load impedance is high.

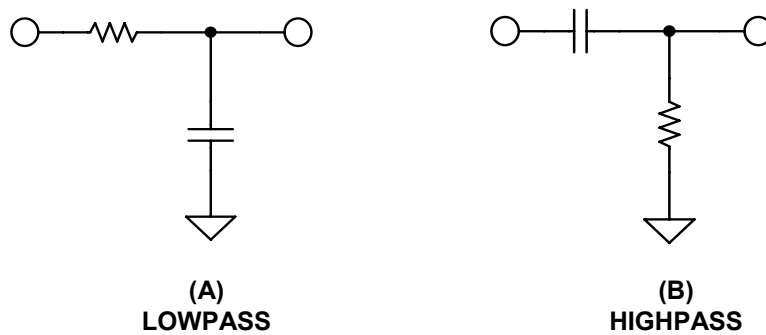

**Figure 8.37: Single-Pole Sections**

The pole can also be incorporated into an amplifier circuit. Figure 8.38(A) shows an amplifier circuit with a capacitor in the feedback loop. This forms a low-pass filter since as frequency is increased, the effective feedback impedance decreases, which causes the gain to decrease.

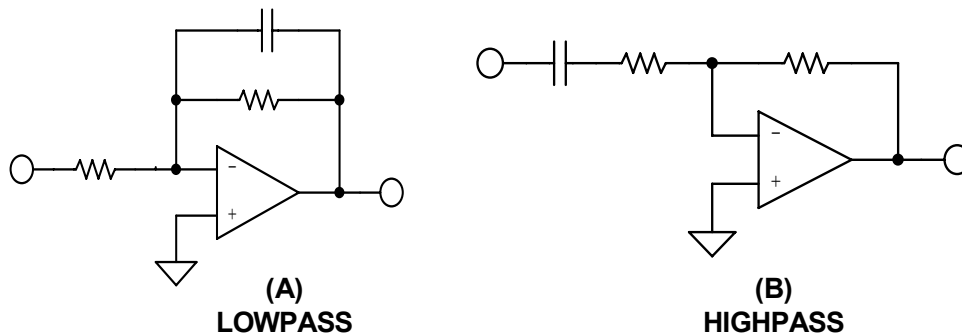

**Figure 8.38: Single-Pole Active Filter Blocks**

Figure 8.38(B) shows a capacitor in series with the input resistor. This causes the signal to be blocked at dc. As the frequency is increased from dc, the impedance of the capacitor decreases and the gain of the circuit increases. This is a high-pass filter.

The design equations for single-pole filters appear in Figure 8.66.

### Passive LC Section

While not strictly a function that uses op amps, passive filters form the basis of several active filters topologies and are included here for completeness.

As in active filters, passive filters are built up of individual subsections. Figure 8.39 shows low-pass filter sections. The full section is the basic two pole section. Odd order filters use one half section which is a single-pole section. The  $m$  derived sections, shown in Figure 8.40, are used in designs requiring transmission zeros as well as poles.

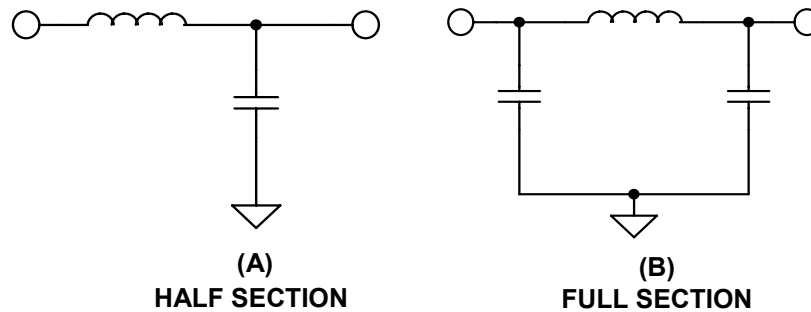

**Figure 8.39:** *Passive Filter Blocks (Low-pass)*

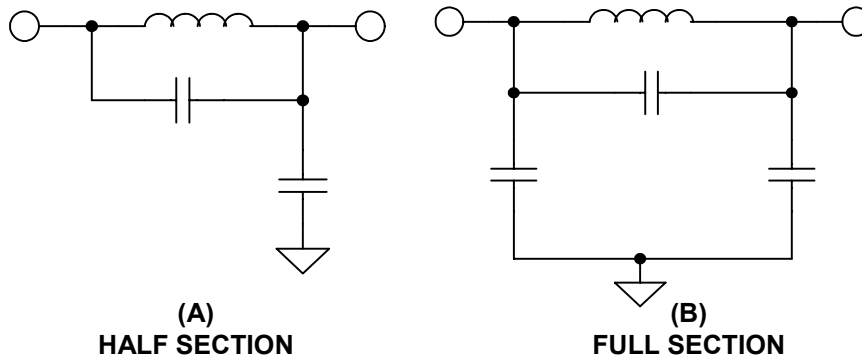

**Figure 8.40:** *Passive Filter Blocks (Low-pass  $m$ -derived)*

A low-pass filter can be transformed into a high-pass (see Figures 8.41 and 8.42) by simply replacing capacitors with inductors with reciprocal values and vice versa so:

$$L_{HP} = \frac{1}{C_{LP}} \quad \text{Eq. 8-84}$$

and

$$C_{HP} = \frac{1}{L_{LP}} \quad \text{Eq. 8-85}$$

## ▣ BASIC LINEAR DESIGN

Transmission zeros are also reciprocated in the transformation so:

$$\omega_{Z,HP} = \frac{1}{\omega_{Z,LP}} \quad \text{Eq. 8-86}$$

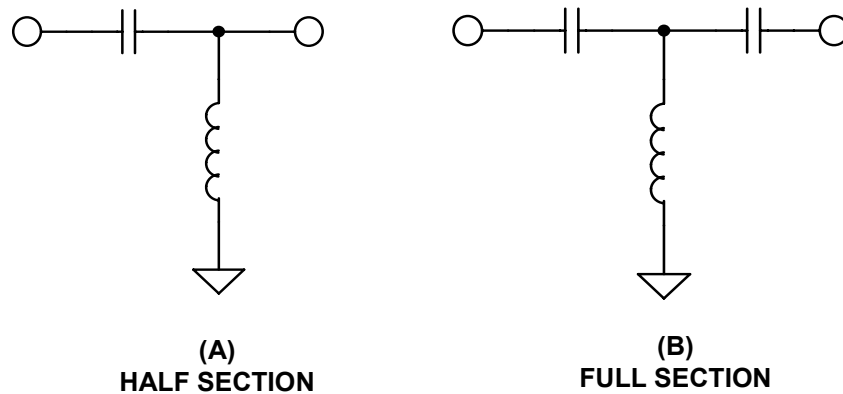

**Figure 8.41:** *Passive Filter Blocks (High-pass)*

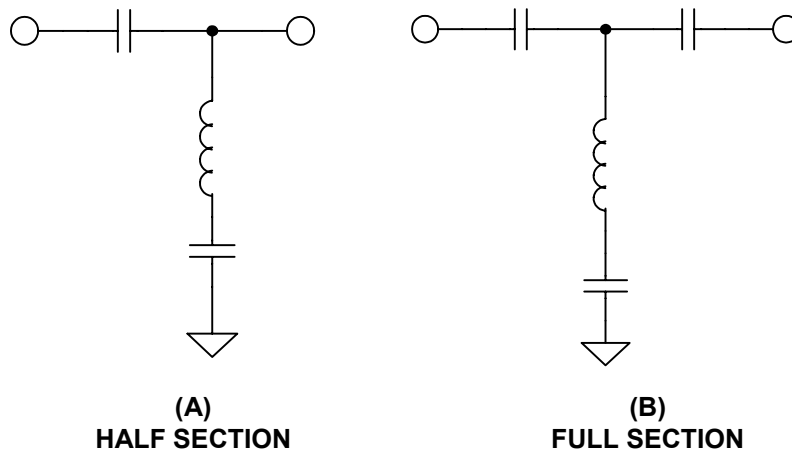
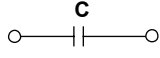
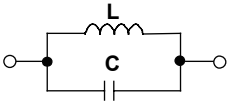
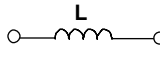
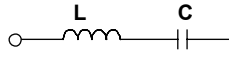
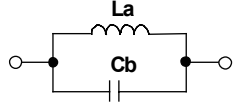
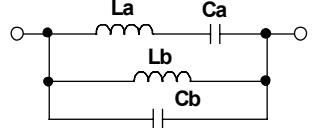
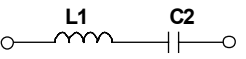
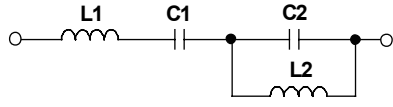

**Figure 8.42:** *Passive Filter Blocks (High-pass m-derived)*

The low-pass prototype is transformed to band-pass and band-reject filters as well by using the table in Figure 8.43.

For a passive filter to operate, the source and load impedances must be specified. One issue with designing passive filters is that in multipole filters each section is the load for the preceding sections and also the source impedance for subsequent sections, so

component interaction is a major concern. Because of this, designers typically make use of tables, such as in William's book (Reference 2).

LOW-PASS BRANCH	BAND-PASS CONFIGURATION	CIRCUIT VALUES
		$C = \frac{1}{\omega_0^2 L}$
		$L = \frac{1}{\omega_0^2 C}$
		$C_a = \frac{1}{\omega_0^2 L_a}$
		$L_b = \frac{1}{\omega_0^2 C_b}$
		$C_1 = \frac{1}{\omega_0^2 L_1}$
		$L_2 = \frac{1}{\omega_0^2 C_2}$
HIGH-PASS BRANCH	BAND-REJECT CONFIGURATION	CIRCUIT VALUES

**Figure 8.43:** Low-pass → Band-pass and High-pass → Band-reject Transformation

### Integrator

Any time that you put a frequency-dependent impedance in a feedback network the inverse frequency response is obtained. For example, if a capacitor, which has a frequency dependent impedance that decreases with increasing frequency, is put in the feedback network of an op amp, an integrator is formed, as in Figure 8.44.

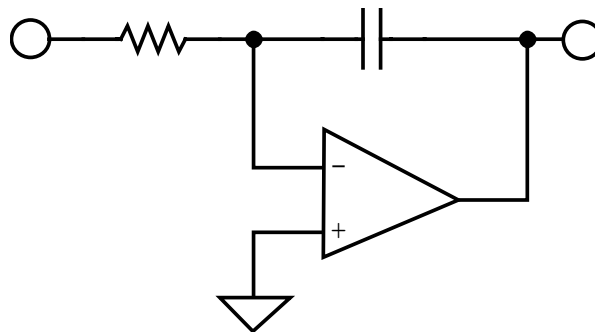

**Figure 8.44:** Integrator

The integrator has high gain (i.e., the open-loop gain of the op amp) at dc. An integrator can also be thought of as a low-pass filter with a cutoff frequency of 0 Hz.

## ▣ BASIC LINEAR DESIGN

### General Impedance Converter

Figure 8.45 is the block diagram of a general impedance converter. The impedance of this circuit is:

$$Z = \frac{Z_1 Z_3 Z_5}{Z_2 Z_4} \quad \text{Eq. 8-87}$$

By substituting one or two capacitors into appropriate locations (the other locations being resistors), several impedances can be synthesized (see Reference 25).

One limitation of this configuration is that the lower end of the structure must be grounded.

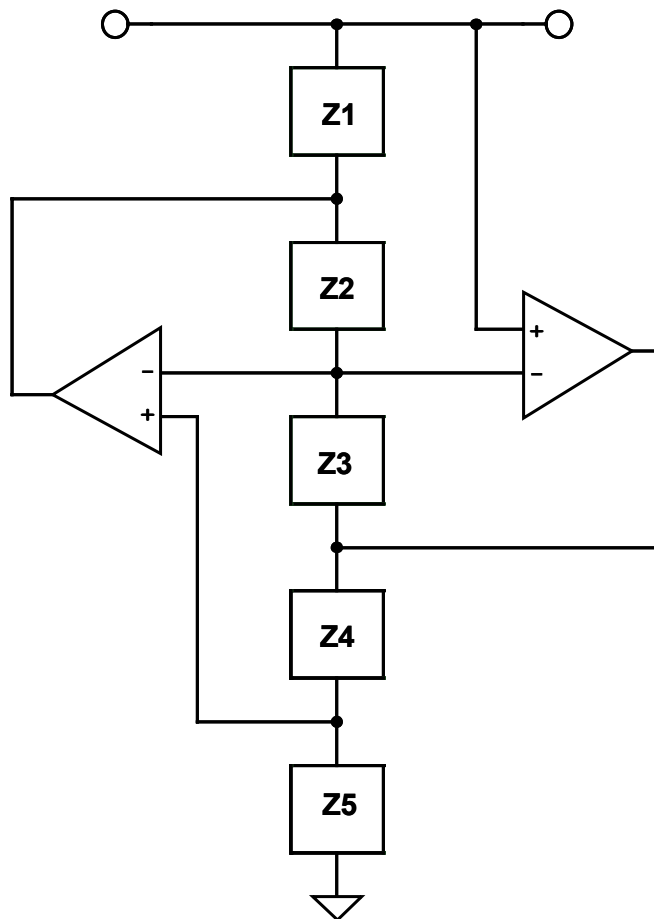

*Figure 8.45: General Impedance Converter*



### Active Inductor

Substituting a capacitor for  $Z_4$  and resistors for  $Z_1$ ,  $Z_2$ ,  $Z_3$  &  $Z_5$  in the GIC results in an impedance given by:

$$Z_{11} = \frac{sC R_1 R_3 R_5}{R_2} \quad \text{Eq. 8-88}$$

By inspection it can be shown that this is an inductor with a value of:

$$L = \frac{C R_1 R_3 R_5}{R_2} \quad \text{Eq. 8-89}$$

This is just one way to simulate an inductor as shown in Figure 8.46.

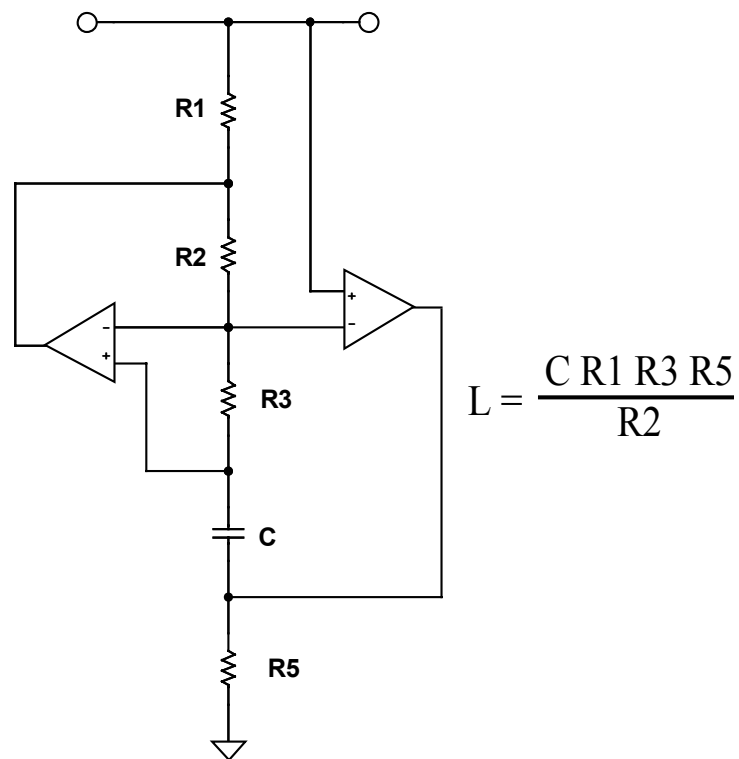

**Figure 8.46:** Active Inductor

## ▣ BASIC LINEAR DESIGN

### Frequency Dependent Negative Resistor (FDNR)

By substituting capacitors for two of the Z1, Z3, or Z5 elements, a structure known as a frequency dependant negative resistance (FDNR) is generated. The impedance of this structure is:

$$Z_{11} = \frac{sC^2 R2 R4}{R5} \quad \text{Eq. 8-90}$$

This impedance, which is called a D element, has the value:

$$D = C^2 R4 \quad \text{Eq. 8-91}$$

assuming

$$C1 = C2 \text{ and } R2 = R5. \quad \text{Eq. 8-92}$$

The three possible versions of the FDNR are shown in Figure 8.47.

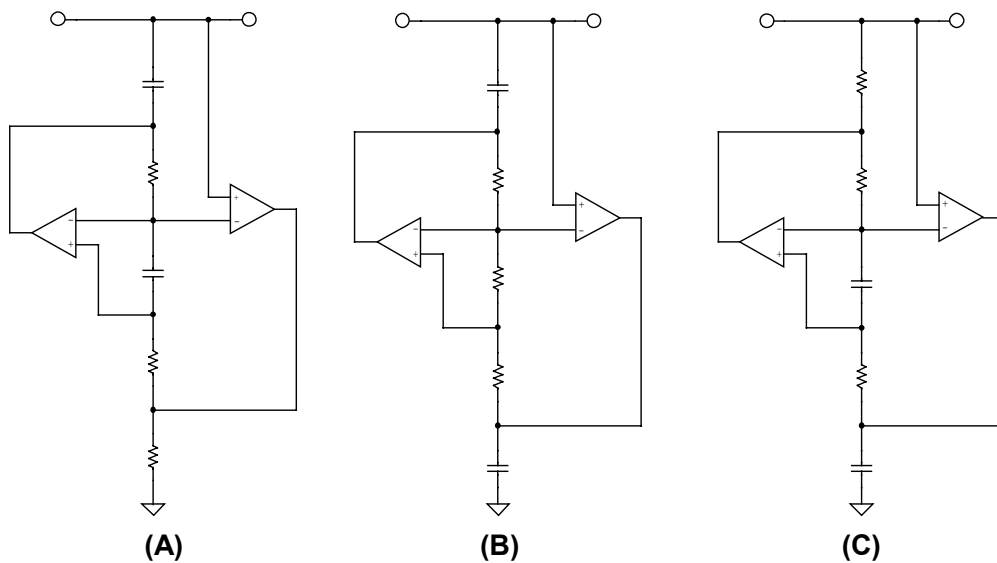
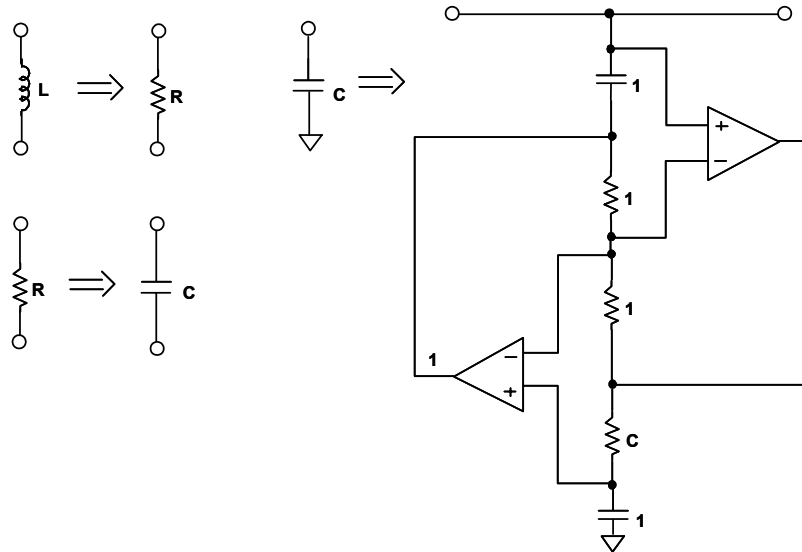

**Figure 8.47:** Frequency Dependent Negative Resistor Blocks

There is theoretically no difference in these three blocks, and so they should be interchangeable. In practice though there may be some differences. Circuit (a) is sometimes preferred because it is the only block to provide a return path for the amplifier bias currents.

For the FDNR filter (see Reference 24), the passive realization of the filter is used as the basis of the design. As in the passive filter, the FDNR filter must then be denormalized for frequency and impedance. This is typically done before the conversion by  $1/s$ . First take the denormalized passive prototype filter and transform the elements by  $1/s$ . This means that inductors, whose impedance is equal to  $sL$ , transform into a resistor with an

impedance of  $L$ . A resistor of value  $R$  becomes a capacitor with an impedance of  $R/s$ ; and a capacitor of impedance  $1/sC$  transforms into a frequency dependent resistor,  $D$ , with an impedance of  $1/s^2C$ . The transformations involved with the FDNR configuration and the GIC implementation of the  $D$  element are shown in Figure 8.48. We can apply this transformation to low-pass, high-pass, band-pass or notch filters, remembering that the FDNR block must be restricted to shunt arms.



**Figure 8.48:**  $1/s$  Transformation

A worked out example of the FDNR filter is included in the next section.

A perceived advantage of the FDNR filter in some circles is that there are no op amps in the direct signal path, which can add noise and/or distortion, however small, to the signal. It is also relatively insensitive to component variation. These advantages of the FDNR come at the expense of an increase in the number of components required.

## ▣ BASIC LINEAR DESIGN

### Sallen-Key

The Sallen-Key configuration, also known as a voltage control voltage source (VCVS), was first introduced in 1955 by R. P. Sallen and E. L. Key of MIT's Lincoln Labs (see Reference 14). It is one of the most widely used filter topologies and is shown in Figure 8.49. One reason for this popularity is that this configuration shows the least dependence of filter performance on the performance of the op amp. This is due to the fact that the op amp is configured as an amplifier, as opposed to an integrator, which minimizes the gain-bandwidth requirements of the op amp. This infers that for a given op amp, you will be able to design a higher frequency filter than with other topologies since the op amp gain bandwidth product will not limit the performance of the filter as it would if it were configured as an integrator. The signal phase through the filter is maintained (noninverting configuration).

Another advantage of this configuration is that the ratio of the largest resistor value to the smallest resistor value and the ratio of the largest capacitor value to the smallest capacitor value (component spread) are low, which is good for manufacturability. The frequency and  $Q$  terms are somewhat independent, but they are very sensitive to the gain parameter. The Sallen-Key is very  $Q$ -sensitive to element values, especially for high  $Q$  sections. The design equations for the Sallen-Key low pass are shown in Figure 8.67.

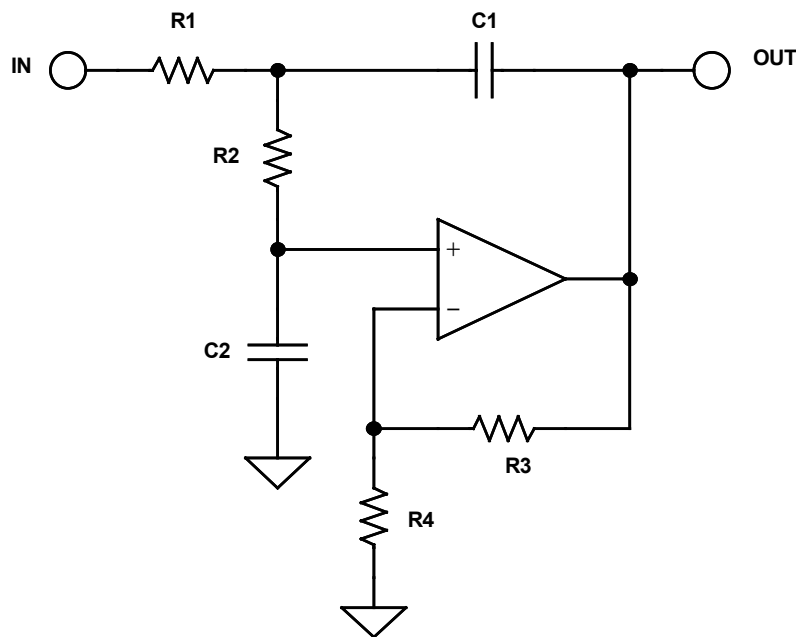

**Figure 8.49:** Sallen-Key Low-pass Filter

There is a special case of the Sallen-Key low-pass filter. If the gain is set to 2, the capacitor values, as well as the resistor values, will be the same.

While the Sallen-Key filter is widely used, a serious drawback is that the filter is not easily tuned, due to interaction of the component values on  $F_0$  and  $Q$ .

To transform the low-pass into the high-pass we simply exchange the capacitors and the resistors in the frequency determining network (i.e. not the amp gain resistors). This is shown in Figure 8.50 (opposite). The comments regarding sensitivity of the filter given above for the low pass case apply to the high-pass case as well. The design equations for the Sallen-Key high-pass are shown in Figure 8.68.

The band-pass case of the Sallen-Key filter has a limitation (see Figure 8.51 below). The value of  $Q$  will determine the gain of the filter, i.e. it can not be set independent, as in the low-pass or high-pass cases. The design equations for the Sallen-Key band-pass are shown in Figure 8.69.

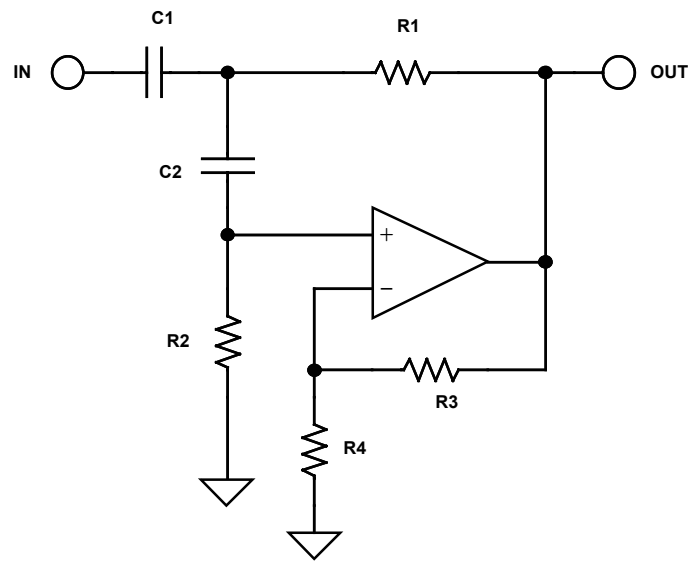

**Figure 8.50: Sallen-Key High-pass Filter**

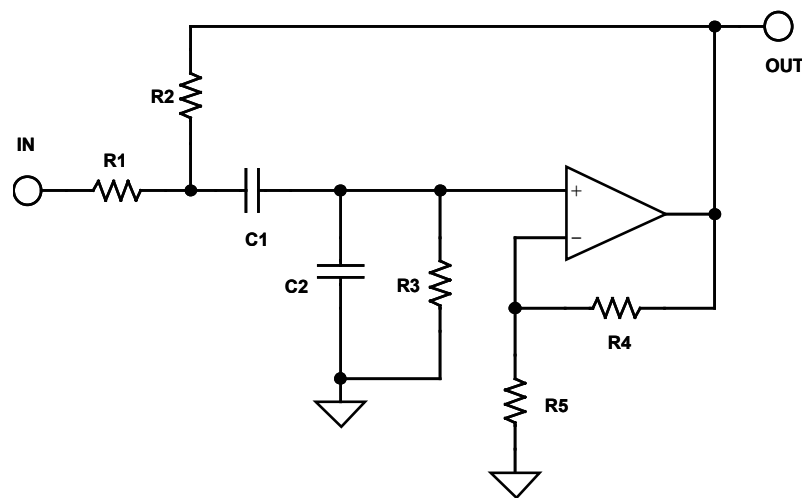

**Figure 8.51: Sallen-Key Band-pass Filter**

A Sallen-Key notch filter may also be constructed, but it has a large number of undesirable characteristics. The resonant frequency, or the notch frequency, can not be

## ▣ BASIC LINEAR DESIGN

adjusted easily due to component interaction. As in the band-pass case, the section gain is fixed by the other design parameters, and there is a wide spread in component values, especially capacitors. Because of this and the availability of easier to use circuits, it is not covered here.

## Multiple Feedback

The multiple feedback filter uses an op amp as an integrator as shown in Figure 8.52 below. Therefore, the dependence of the transfer function on the op amp parameters is greater than in the Sallen-Key realization. It is hard to generate high Q, high frequency sections due to the limitations of the open-loop gain of the op amp. A rule of thumb is that the open-loop gain of the op amp should be at least 20 dB ( $\times 10$ ) above the amplitude response at the resonant (or cutoff) frequency, including the peaking caused by the Q of the filter. The peaking due to Q will cause an amplitude,  $A_0$ :

$$A_0 = H Q \qquad \text{Eq. 8-92}$$

where H is the gain of the circuit. The multiple feedback filter will invert the phase of the signal. This is equivalent to adding the resulting  $180^\circ$  phase shift to the phase shift of the filter itself.

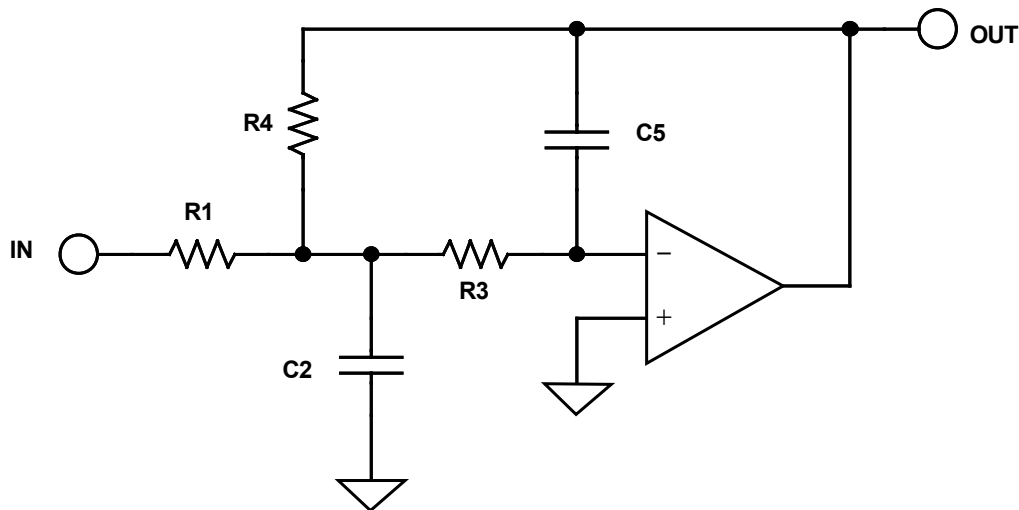

**Figure 8.52: Multiple Feedback Low-pass**

The maximum to minimum component value ratios is higher in the multiple feedback case than in the Sallen-Key realization. The design equations for the multiple feedback low-pass are given in Figure 8.70.

Comments made about the multiple feedback low-pass case apply to the high-pass case as

well (see Figure 8.53 opposite). Note that we again swap resistors and capacitors to convert the low-pass case to the high-pass case. The design equations for the multiple feedback high-pass are given in Figure 8.71.

The design equations for the multiple feedback band-pass case (see Figure 8.54 opposite) are given in Figure 8.72.

## ▣ BASIC LINEAR DESIGN

This circuit is widely used in low  $Q$  ( $< 20$ ) applications. It allows some tuning of the resonant frequency,  $F_0$ , by making  $R_2$  variable.  $Q$  can be adjusted (with  $R_5$ ) as well, but this will also change  $F_0$ .

Tuning of  $F_0$  can be accomplished by monitoring the output of the filter with the horizontal channel of an oscilloscope, with the input to the filter connected to the vertical channel. The display will be a Lissajous pattern. This pattern will be an ellipse that will collapse to a straight line at resonance, since the phase shift will be  $180^\circ$ . You could also adjust the output for maximum output, which will also occur at resonance, but this is usually not as precise, especially at lower values of  $Q$  where there is a less pronounced peak.

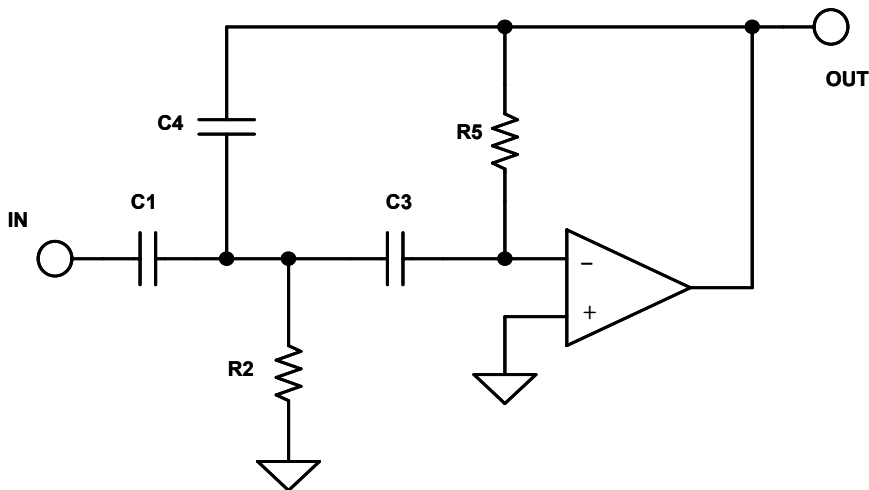

*Figure 8.53: Multiple Feedback High-Pass*

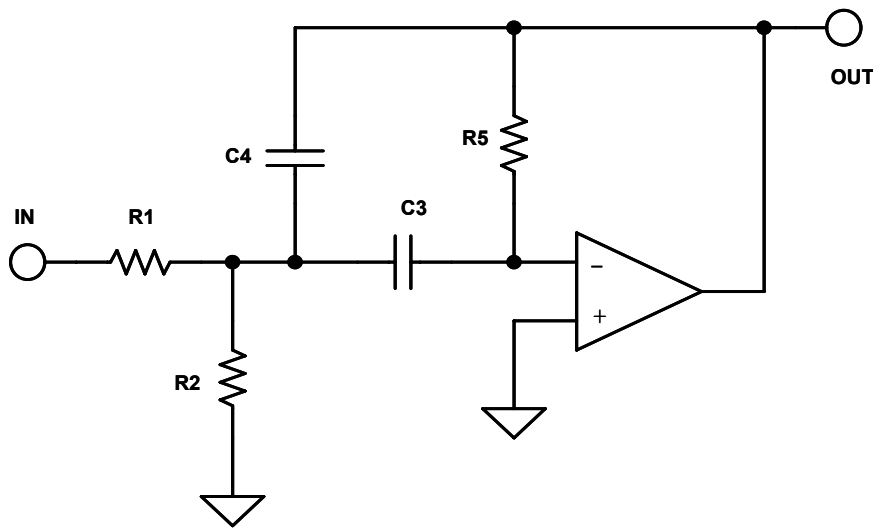
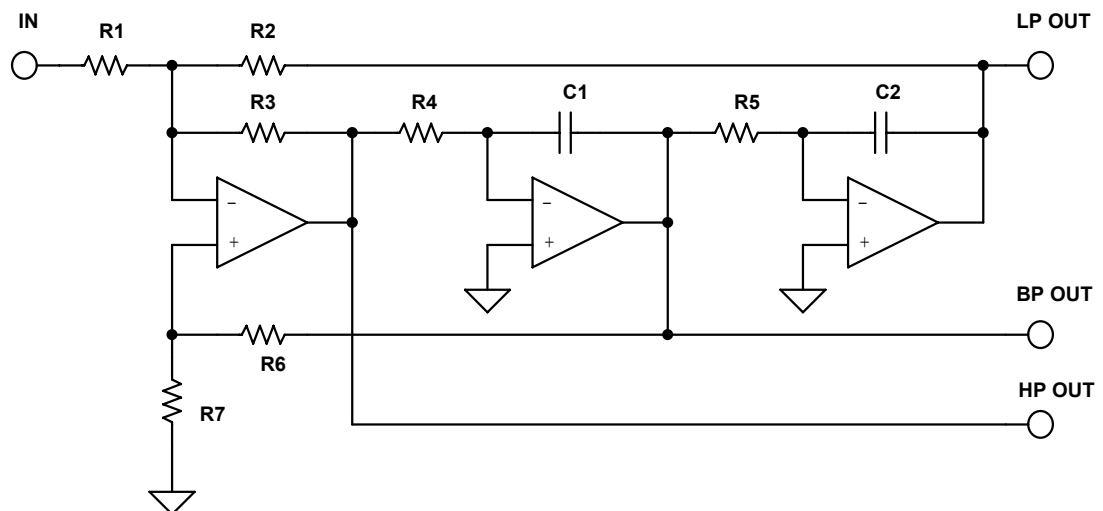

*Figure 8.54: Multiple Feedback Band-Pass*



## State Variable

The state-variable realization (see Reference 11) is shown in Figure 8.55, along with the design equations in Figure 8.73. This configuration offers the most precise implementation, at the expense of many more circuit elements. All three major parameters (gain,  $Q$  &  $\omega_0$ ) can be adjusted independently, and low-pass, high-pass, and band-pass outputs are available simultaneously. Note that the low-pass and high-pass outputs are inverted in phase while the band-pass output maintains the phase. The gain of each of the outputs of the filter is also independently variable. With an added amplifier section summing the low-pass and high-pass sections the notch function can also be synthesized. By changing the ratio of the summed sections, low-pass notch, standard notch and high-pass notch functions can be realized. A standard notch may also be realized by subtracting the band-pass output from the input with the added op amp section. An all-pass filter may also be built with the four amplifier configuration by subtracting the band-pass output from the input. In this instance, the band-pass gain must equal 2.



**Figure 8.55: State Variable Filter**

Since all parameters of the state variable filter can be adjusted independently, component spread can be minimized. Also, variations due to temperature and component tolerances are minimized. The op amps used in the integrator sections will have the same limitations on op amp gain-bandwidth as described in the multiple feedback section.

Tuning the resonant frequency of a state variable filter is accomplished by varying  $R_4$  and  $R_5$ . While you don't have to tune both, if you are varying over a wide range it is generally preferable. Holding  $R_1$  constant, tuning  $R_2$  sets the low-pass gain and tuning  $R_3$  sets the high-pass gain. Band-pass gain and  $Q$  are set by the ratio of  $R_6$  &  $R_7$ .

Since the parameters of a state variable filter are independent and tunable, it is easy to add electronic control of frequency,  $Q$  and  $\omega_0$ . This adjustment is accomplished by using

## ▣ BASIC LINEAR DESIGN

an analog multiplier, multiplying DACs (MDACs) or digital pots, as shown in one of the examples in a later section. For the integrator sections adding the analog multiplier or MDAC effectively increases the time constant by dividing the voltage driving the resistor, which, in turn, provides the charging current for the integrator capacitor. This in effect raises the resistance and, in turn, the time constant. The Q and gain can be varied by changing the ratio of the various feedback paths. A digital pot will accomplish the same feat in a more direct manner, by directly changing the resistance value. The resultant tunable filter offers a great deal of utility in measurement and control circuitry. A worked out example is given in Section 8 of this chapter.



## ▣ BASIC LINEAR DESIGN

### Dual Amplifier Band-Pass (DABP)

The dual amplifier band-pass filter structure is useful in designs requiring high  $Q$ s and high frequencies. Its component sensitivity is small, and the element spread is low. A useful feature of this circuit is that the  $Q$  and resonant frequency can be adjusted more or less independently.

Referring to Figure 8.57 below, the resonant frequency can be adjusted by  $R2$ .  $R1$  can then be adjusted for  $Q$ . In this topology it is useful to use dual op amps. The match of the two op amps will lower the sensitivity of  $Q$  to the amplifier parameters.

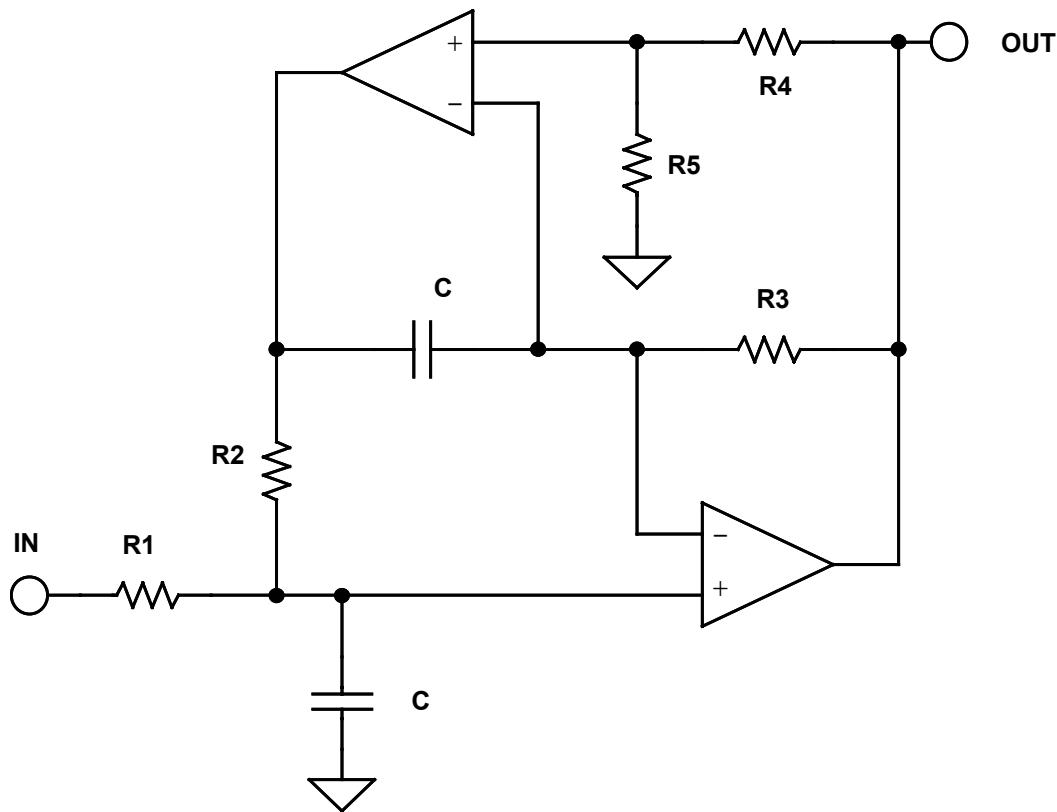
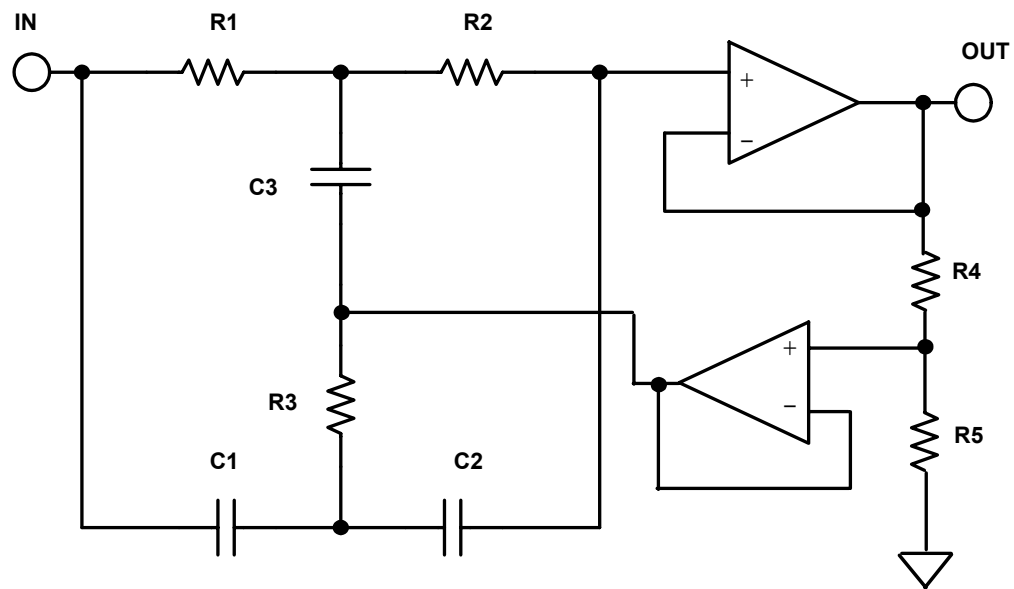

**Figure 8.57:** Dual Amplifier Band-Pass Filter

It should be noted that the DABP has a gain of 2 at resonance. If lower gain is required, resistor  $R1$  may be split to form a voltage divider. This is reflected in the addendum to the design equations of the DABP, Figure 8.75.

## Twin T Notch

The twin T is widely used as a general purpose notch circuit as shown in Figure 8.58. The passive implementation of the twin T (i.e. with no feedback) has a major shortcoming of having a  $Q$  that is fixed at 0.25. This issue can be rectified with the application of positive feedback to the reference node. The amount of the signal feedback, set by the  $R4/R5$  ratio, will determine the value of  $Q$  of the circuit, which, in turn, determines the notch depth. For maximum notch depth, the resistors  $R4$  and  $R5$  and the associated op amp can be eliminated. In this case, the junction of  $C3$  and  $R3$  will be directly connected to the output.



**Figure 8.58:** Twin-T Notch Filter

Tuning is not easily accomplished. Using standard 1% components a 60 dB notch is as good as can be expected, with 40 dB to 50 dB being more typical.

The design equations for the Twin T are given in Figure 8.76.

## ▣ BASIC LINEAR DESIGN

### Bainter Notch

A simple notch filter is the Bainter circuit (see Reference 21). It is composed of simple circuit blocks with two feedback loops as shown in Figure 8.59. Also, the component sensitivity is very low.

This circuit has several interesting properties. The  $Q$  of the notch is not based on component matching as it is in every other implementation, but is instead only dependant on the gain of the amplifiers. Therefore, the notch depth will not drift with temperature, aging and other environmental factors. The notch frequency may shift, but not the depth.

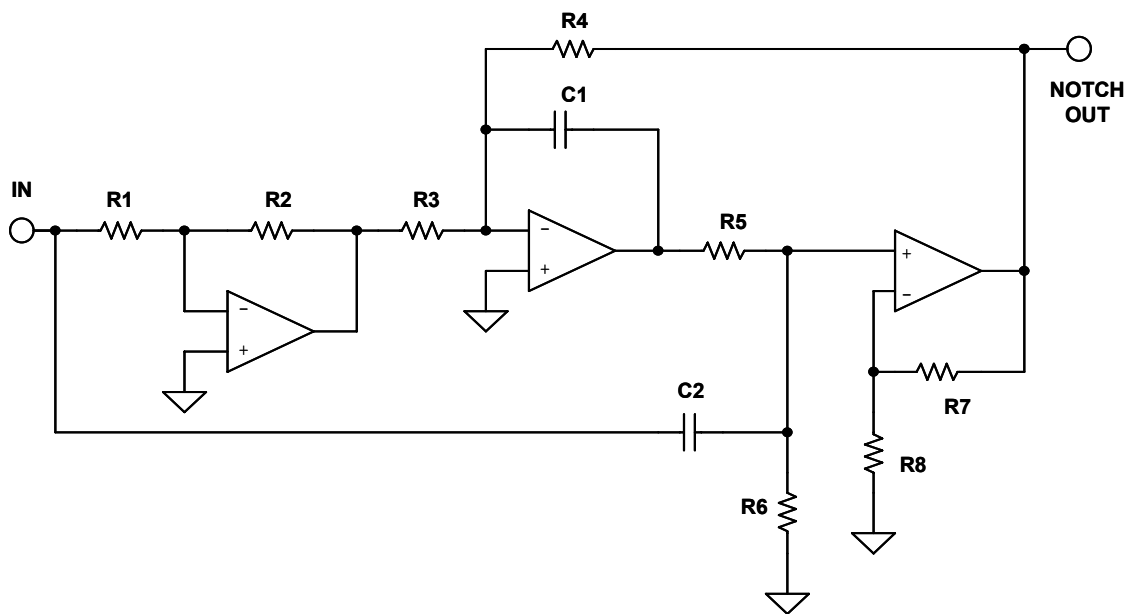

**Figure 8.59:** Bainter Notch Filter

Amplifier open loop gain of  $10^4$  will yield a  $Q_z$  of  $> 200$ . It is capable of orthogonal tuning with minimal interaction.  $R_6$  tunes  $Q$  and  $R_1$  tunes  $\omega_z$ . Varying  $R_3$  sets the ratio of  $\omega_0/\omega_z$  produces lowpass notch ( $R_4 > R_3$ ), notch ( $R_4 = R_3$ ) or highpass notch ( $R_4 < R_3$ ).

The design equations of the Bainter circuit are given in Figure 8.77.

### Boctor Notch

The Boctor circuits (see References 22, 23), while moderately complicated, uses only one op amp. Due to the number of components, there is a great deal of latitude in component selection. These circuits also offer low sensitivity and the ability to tune the various parameters more or less independently.

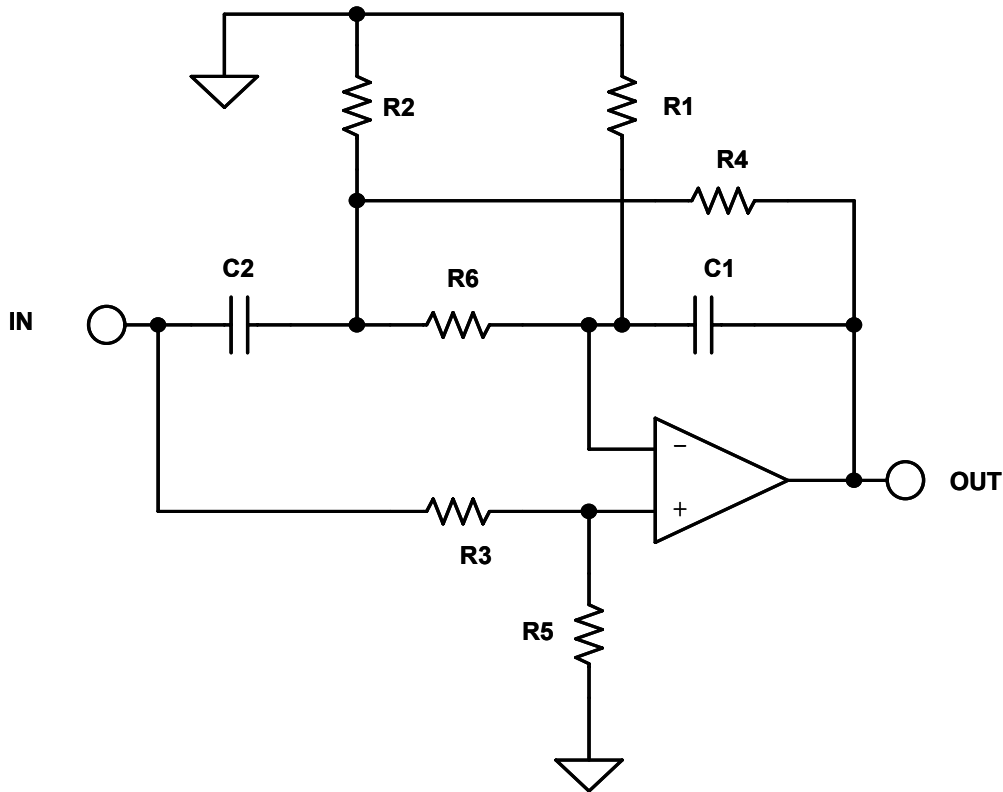

**Figure 8.60: Boctor Low-Pass Notch Filter**

There are two forms, a low-pass notch (Figure 8.60 above) and a high-pass notch (Figure 8.61 below). For the low-pass case, the preferred order of adjustment is to tune  $\omega_0$  with

R4, then  $Q_0$  with R2, next  $Q_z$  with R3 and finally  $\omega_z$  with R1.

In order for the components to be realizable we must define a variable,  $k_1$ , such that:

$$\frac{\omega_0^2}{\omega_z^2} < k_1 < 1 \quad \text{Eq. 8-94}$$

The design equations are given in Figure 8.78 for the low-pass case and in Figure 8.79 for the high-pass case.

## ▣ BASIC LINEAR DESIGN

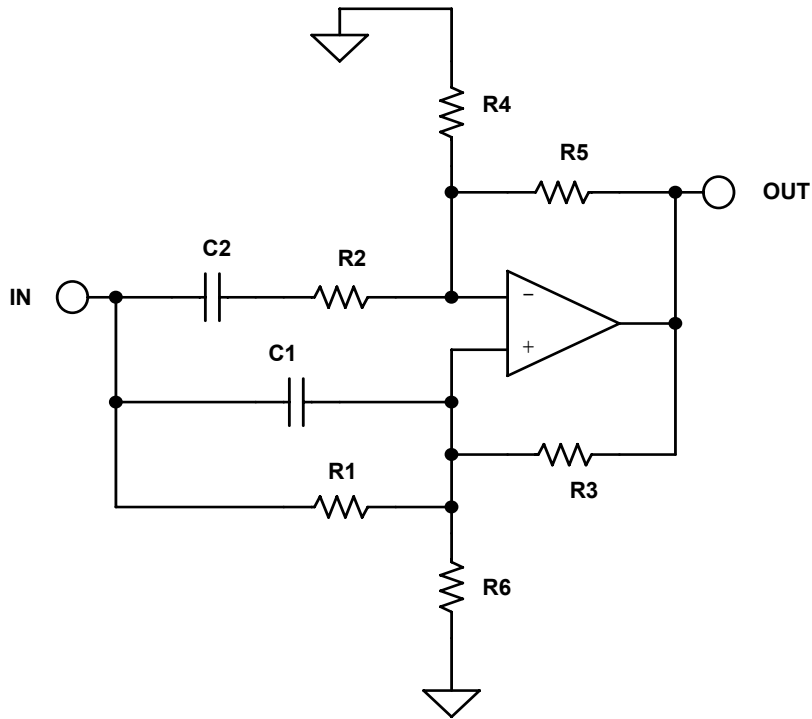

**Figure 8.61:** Boctor High-Pass Filter

In the high-pass case circuit gain is require and it applies only when

$$Q < \frac{1}{1 - \frac{\omega_z^2}{\omega_0^2}} \quad \text{Eq. 8-95}$$

but a high-pass notch can be realized with one amplifier and only two capacitors, which can be the same value. The pole and zero frequencies are completely independent of the amplifier gain. The resistors can be trimmed so that even 5% capacitors can be used.



## "1 - Bandpass" Notch

As mentioned in the state variable and biquad sections, a notch filter can be built as 1 - BP. The band-pass section can be any of the all pole band-pass realizations discussed above, or any others. Keep in mind whether the band-pass section is inverting as shown in Figure 8.62 (such as the multiple feedback circuit) or noninverting as shown in Figure 8.63 (such as the Sallen-Key), since we want to subtract, not add, the band-pass output from the input.

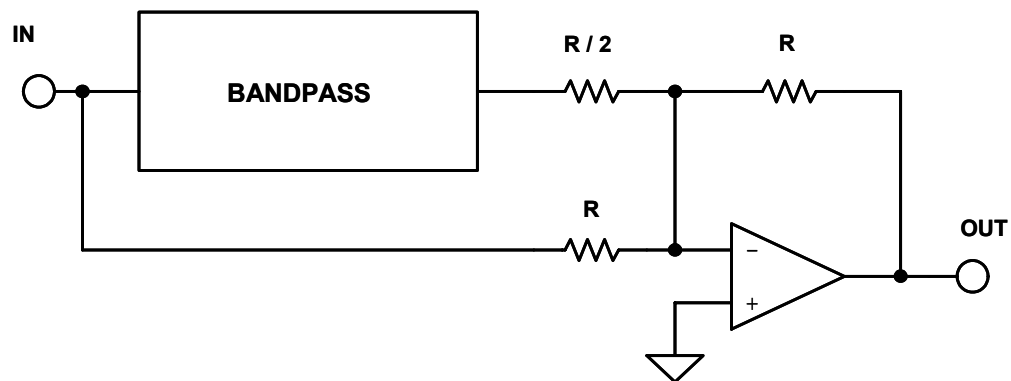

*Figure 8.62: 1 - BP Filter for Inverting Band-Pass Configurations*

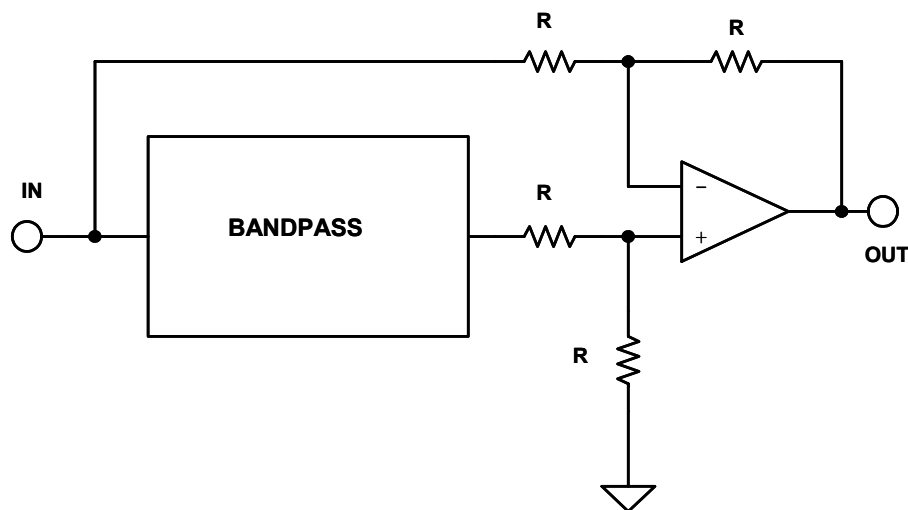

*Figure 8.63: 1 - BP Filter for Noninverting Band-Pass Configurations*

It should be noted that the gain of the band-pass amplifier must be taken into account in determining the resistor values. Unity gain band-pass would yield equal values.

## ▣ BASIC LINEAR DESIGN

### First Order All-Pass

The general form of a first order all-pass filter is shown in Figure 8.64. If the function is a simple RC high-pass (Figure 8.64A), the circuit will have a phase shift that goes from  $-180^\circ$  at 0 Hz. and  $0^\circ$  at high frequency. It will be  $-90^\circ$  at  $\omega = 1/RC$ . The resistor may be made variable to allow adjustment of the delay at a particular frequency.

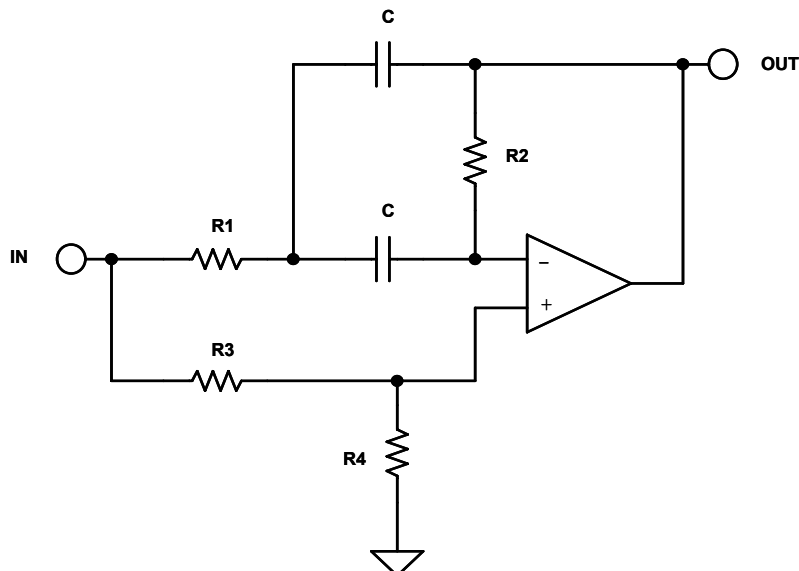
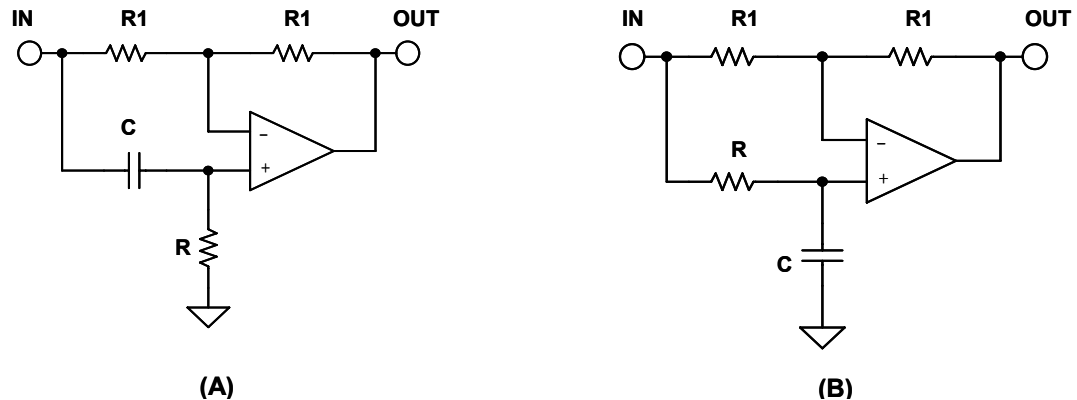

**Figure 8.64:** First Order All-Pass Filters

If the function is changed to a low-pass function (Figure 8.64B), the filter is still a first order all-pass and the delay equations still hold, but the signal is inverted, changing from  $0^\circ$  at dc to  $-180^\circ$  at high frequency.

## Second Order All-Pass

A second order all-pass circuit shown in Figure 8.65 was first described by Delyiannis (see Reference 17). The main attraction of this circuit is that it only requires one op amp. Remember also that an all-pass filter can also be realized as 1 – 2BP.



**Figure 8.65: Second Order All-Pass Filter**

We may use any of the all pole realizations discussed above to build the filter, but you need to be aware of whether the BP inverts the phase or not. We must also be aware that the gain of the BP section must be 2. To this end, the DABP structure is particularly useful, since its gain is fixed at 2.

Figures 8.66 through 8.81 following summarize design equations for various active filter realizations. In all cases,  $H$ ,  $\omega_0$ ,  $Q$ , and  $\alpha$  are given, being taken from the design tables.

## SINGLE POLE

### LOWPASS

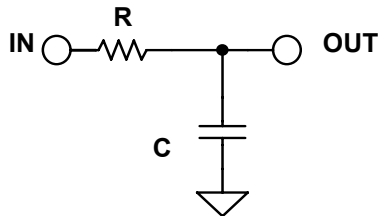

$$\frac{V_O}{V_{IN}} = \frac{1}{sCR + 1}$$

$$F_o = \frac{1}{2\pi RC}$$

### HIGHPASS

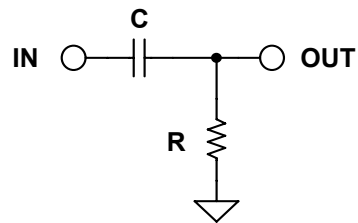

$$\frac{V_O}{V_{IN}} = \frac{sCR}{sCR + 1}$$

$$F_o = \frac{1}{2\pi RC}$$

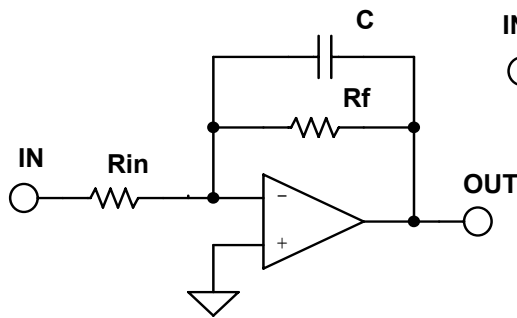

$$\frac{V_O}{V_{IN}} = - \frac{R_f}{R_{in}} \frac{1}{sCR + 1}$$

$$H_o = - \frac{R_f}{R_{in}}$$

$$F_o = \frac{1}{2\pi R_f C}$$

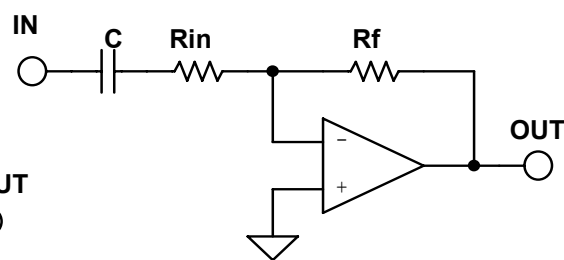

$$\frac{V_O}{V_{IN}} = - \frac{R_f}{R_{in}} \frac{sCR}{sCR + 1}$$

$$H_o = - \frac{R_f}{R_{in}}$$

$$F_o = \frac{1}{2\pi R_{in} C}$$

Figure 8.66: Single-Pole Filter Design Equations

## SALLEN-KEY LOWPASS

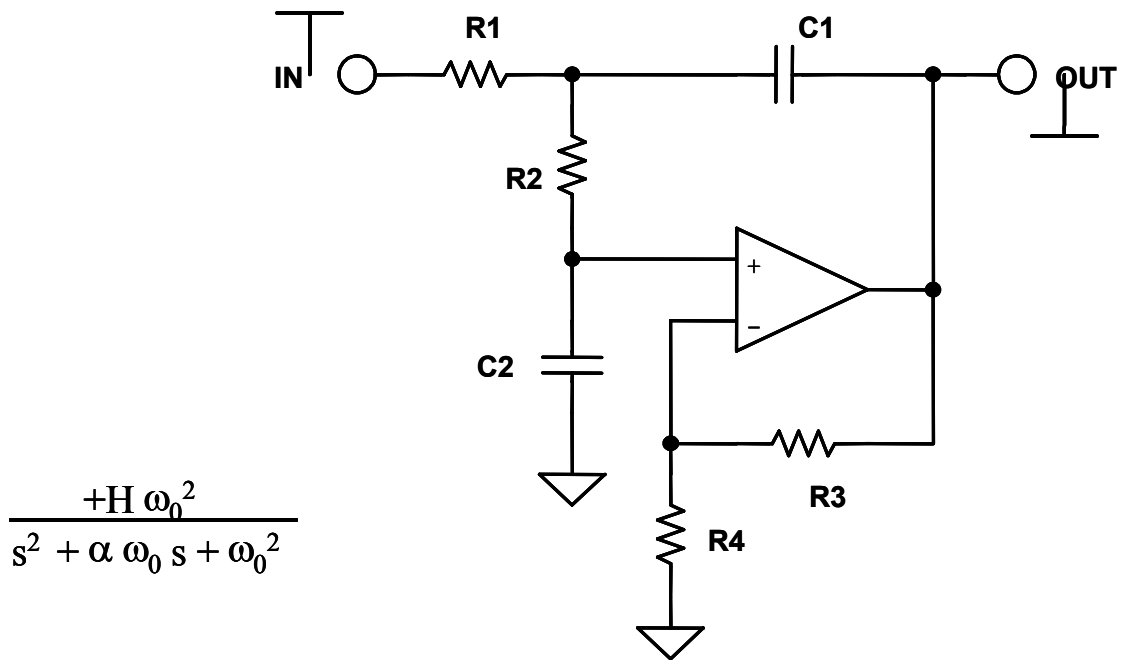

$$\frac{+H \omega_0^2}{s^2 + \alpha \omega_0 s + \omega_0^2}$$

$$\frac{V_O}{V_{IN}} = \frac{H \frac{1}{R_1 R_2 C_1 C_2}}{s^2 + s \left[ \left( \frac{1}{R_1} + \frac{1}{R_2} \right) \frac{1}{C_1} + \frac{(1-H)}{R_2 C_2} \right] + \frac{1}{R_1 R_2 C_1 C_2}}$$

CHOOSE: C1 R3  
 .....

THEN:  $k = 2 \pi F_0 C_1$   $R_4 = \frac{R_3}{(H-1)}$   
 $m = \frac{\alpha^2}{4} + (H-1)$

$$C_2 = m C_1$$

$$R_1 = \frac{2}{\alpha k}$$

$$R_2 = \frac{\alpha}{2mk}$$

Figure 8.67: Sallen-Key Low-Pass Design Equations

## SALLEN-KEY HIGHPASS

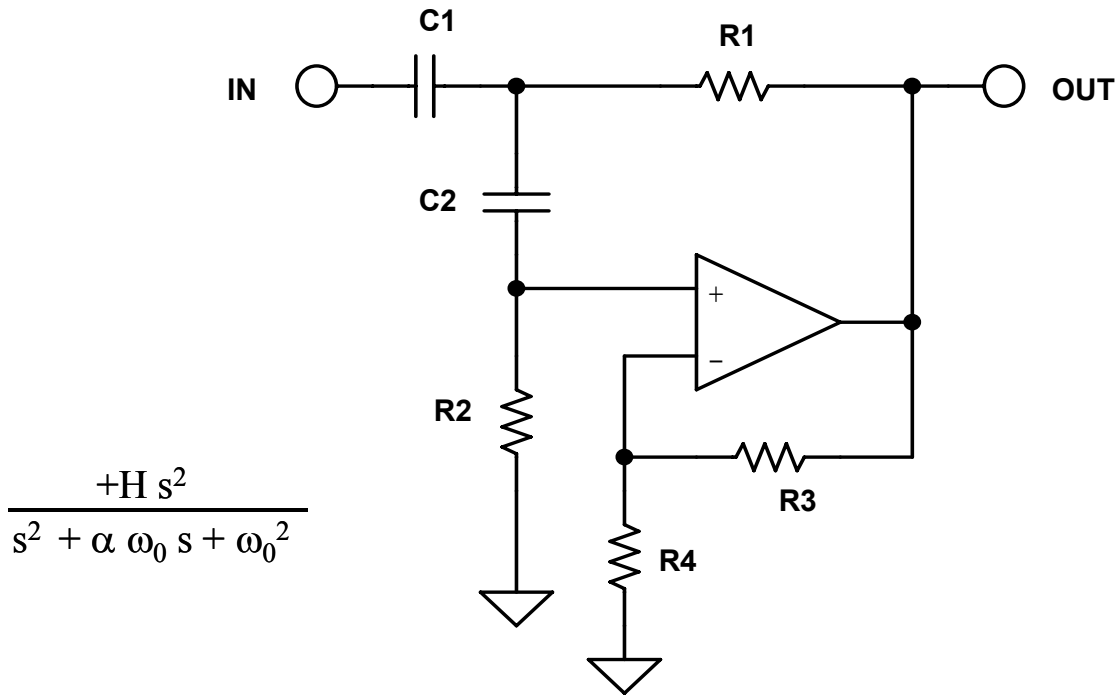

$$\frac{+H s^2}{s^2 + \alpha \omega_0 s + \omega_0^2}$$

$$\frac{V_O}{V_{IN}} = \frac{H s^2}{s^2 + s \left[ \frac{\frac{C2}{R2} + \frac{C1}{R2} + (1-H)\frac{C2}{R1}}{C1 C2} \right] + \frac{1}{R1 R2 C1 C2}}$$

CHOOSE: C1 R3

---

THEN:  $k = 2 \pi F_0 C1$   $R4 = \frac{R3}{(H-1)}$

$$C2 = C1$$

$$R1 = \frac{\alpha + \sqrt{\alpha^2 + (H-1)}}{4 k}$$

$$R2 = \frac{4}{\alpha + \sqrt{\alpha^2 + (H-1)}} * \frac{1}{k}$$

Figure 8.68: Sallen-Key High-Pass Design Equations

## SALLEN-KEY BANDPASS

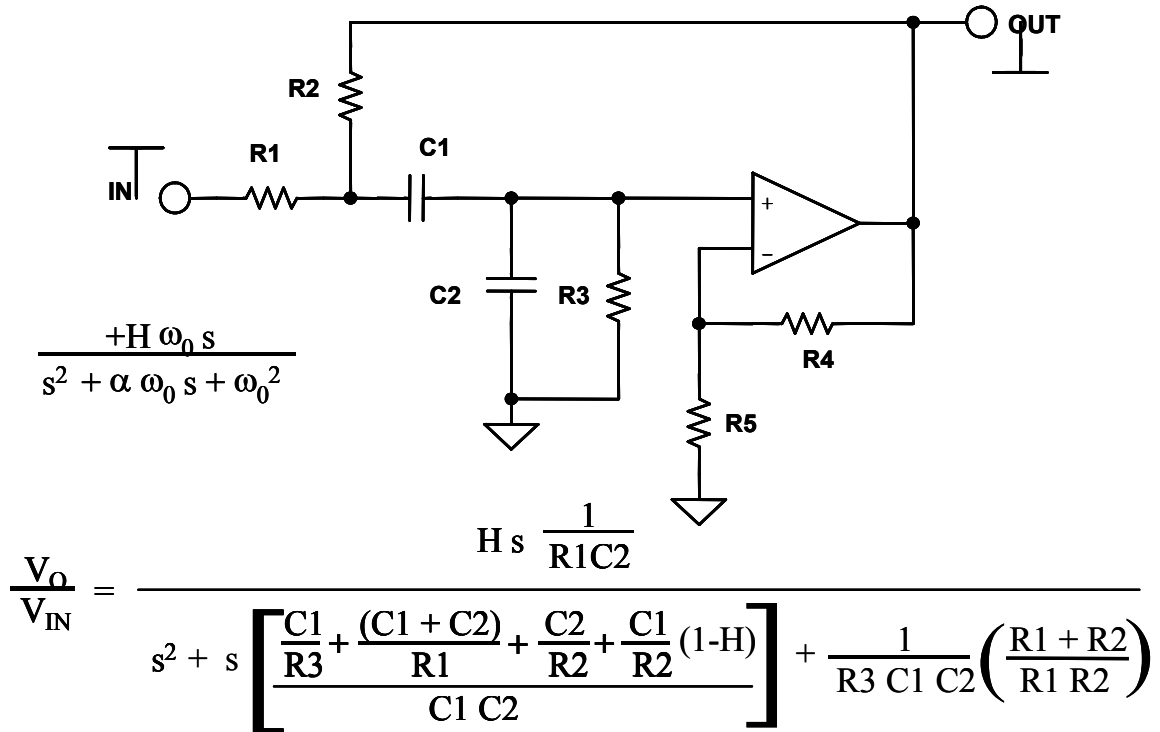

CHOOSE:	C1	R4
THEN:	$k = 2 \pi F_0 C1$	$R5 = \frac{R4}{(H-1)}$
	$C2 = \frac{1}{2} C1$	
	$R1 = \frac{2}{k}$	
	$R2 = \frac{2}{3k}$	
	$R3 = \frac{4}{k}$	
	$H = \frac{1}{3} \left( 6.5 - \frac{1}{Q} \right)$	

Figure 8.69: Sallen-Key Band-Pass Design Equations

## MULTIPLE FEEDBACK LOWPASS

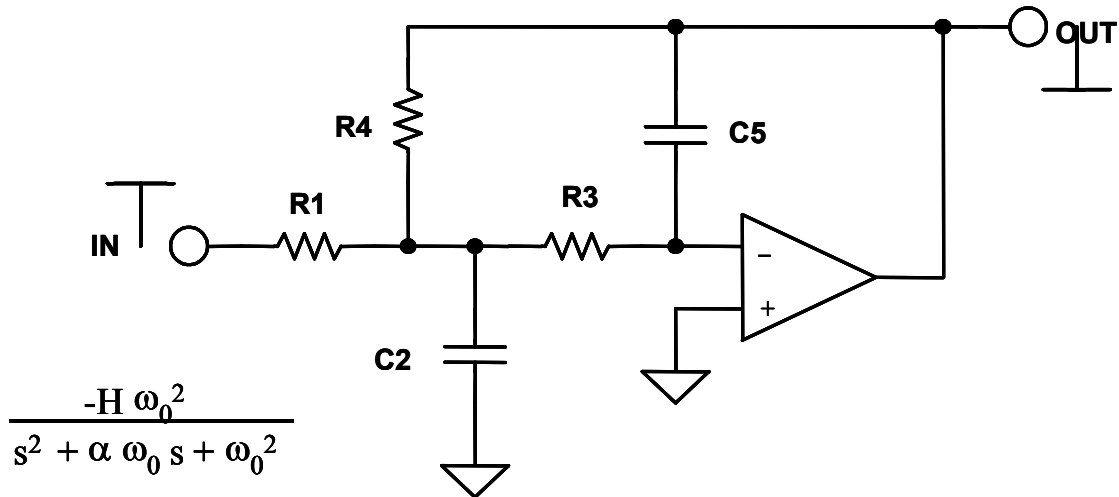

$$\frac{-H \omega_0^2}{s^2 + \alpha \omega_0 s + \omega_0^2}$$

$$\frac{V_O}{V_{IN}} = \frac{-H \frac{1}{R_1 R_3 C_2 C_5}}{s^2 + s \frac{1}{C_2} \left( \frac{1}{R_1} + \frac{1}{R_3} + \frac{1}{R_4} \right) + \frac{1}{R_3 R_4 C_2 C_5}}$$

CHOOSE: C5

THEN:  $k = 2 \pi F_0 C_5$

$$C_2 = \frac{4}{\alpha^2} (H + 1) C_5$$

$$R_1 = \frac{\alpha}{2 H k}$$

$$R_3 = \frac{\alpha}{2 (H + 1) k}$$

$$R_4 = \frac{\alpha}{2 k}$$

Figure 8.70: Multiple Feedback Low-Pass Design Equations



## MULTIPLE FEEDBACK HIGHPASS

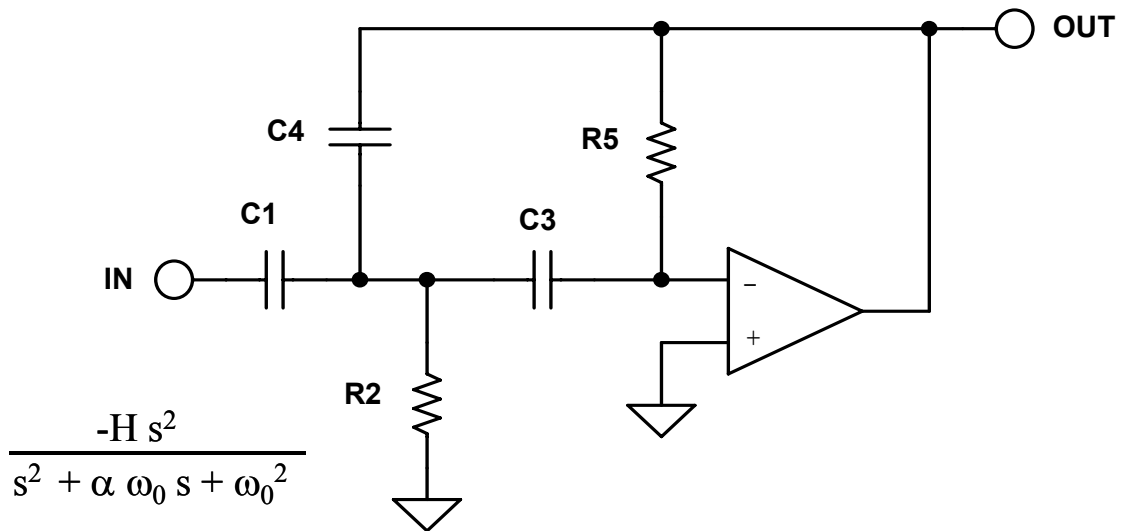

$$\frac{-H s^2}{s^2 + \alpha \omega_0 s + \omega_0^2}$$

$$\frac{V_O}{V_{IN}} = \frac{-s^2 \frac{C1}{C4}}{s^2 + s \frac{(C1 + C3 + C4)}{C3 C4 R5} + \frac{1}{R2 R5 C3 C4}}$$

CHOOSE: C1

.....

THEN:  $k = 2 \pi F_O C1$

$$C3 = C1$$

$$C4 = \frac{C1}{H}$$

$$R2 = \frac{\alpha}{k \left(2 + \frac{1}{H}\right)}$$

$$R5 = \frac{H \left(2 + \frac{1}{H}\right)}{\alpha k}$$

Figure 8.71: Multiple Feedback High-Pass Design Equations

## MULTIPLE FEEDBACK BANDPASS

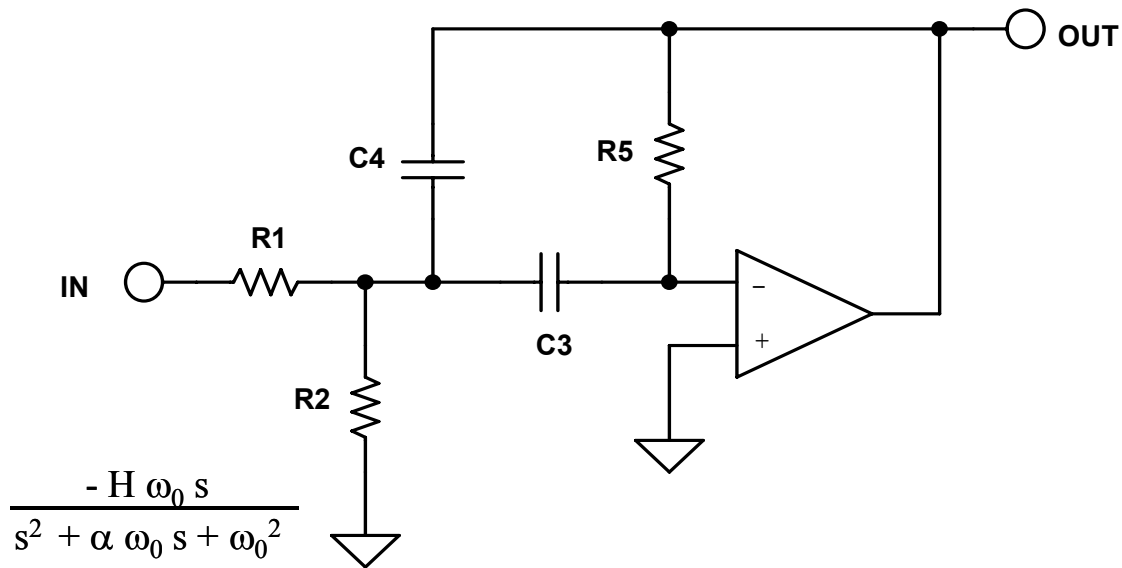

$$\frac{V_O}{V_{IN}} = \frac{-s \frac{1}{R1 C4}}{s^2 + s \frac{(C3 + C4)}{C3 C4 R5} + \frac{1}{R5 C3 C4} \left( \frac{1}{R1} + \frac{1}{R2} \right)}$$

CHOOSE: C3  
.....

THEN:  $k = 2 \pi F_0 C3$

$$C4 = C3$$

$$R1 = \frac{1}{H k}$$

$$R2 = \frac{1}{(2Q - H) k}$$

$$R5 = \frac{2Q}{k}$$

Figure 8.72: Multiple Feedback Band-Pass Design Equations

## STATE VARIABLE (A)

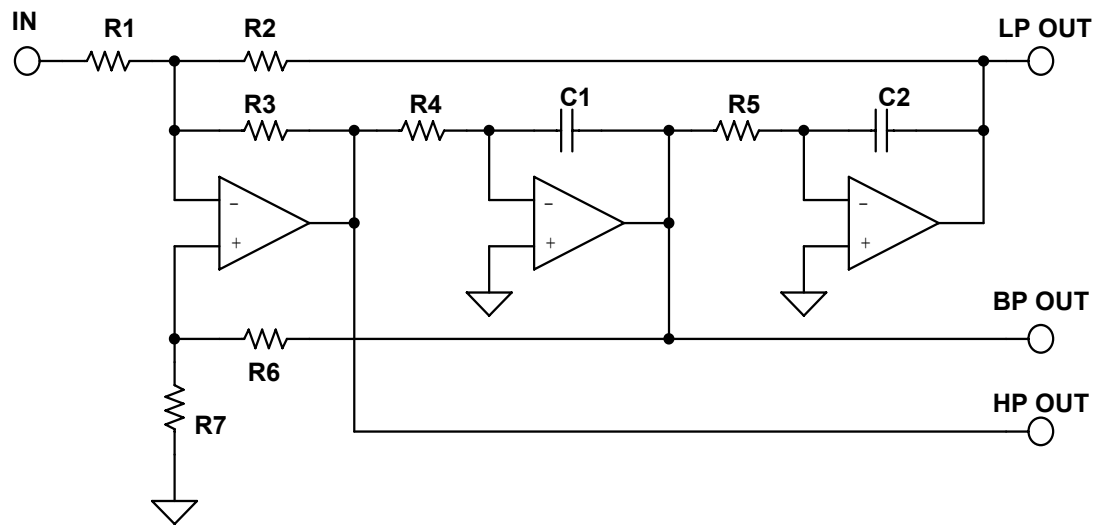

$$A_{LP(s=0)} = -\frac{R2}{R1}$$

$$A_{HP(s=\infty)} = -\frac{R3}{R1}$$

$$\omega_0 = \sqrt{\frac{R3}{R2 R4 R5 C1 C2}}$$

LET  $R4 = R5 = R, C1 = C2 = C$

$$A_{BP(s=\omega_0)} = \frac{\frac{R6 + R7}{R7}}{R1 \left( \frac{1}{R1} + \frac{1}{R2} + \frac{1}{R3} \right)}$$

CHOOSE R1:

$$R2 = A_{LP} R1$$

$$R3 = A_{HP} R1$$

CHOOSE C:

$$R = \frac{1}{2\pi F_0 C} \sqrt{\frac{A_{HP}}{A_{LP}}}$$

CHOOSE R7:

$$R6 =$$

$$R7 \sqrt{R2 R3} Q \left( \frac{1}{\frac{1}{R1} + \frac{1}{R2} + \frac{1}{R3}} \right)$$

Figure 8.73A: State Variable Design Equations

## STATE VARIABLE (B)

FOR NOTCH:

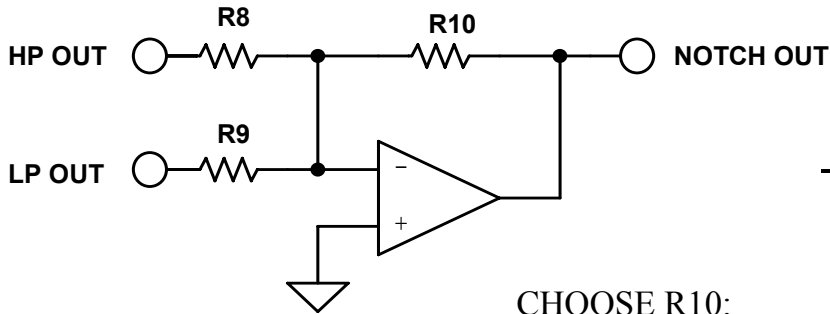

$$\frac{\omega_z^2}{\omega_0^2} = \frac{R9 R2}{R8 R3}$$

CHOOSE R10:

CHOOSE  $A_{HP}$ ,  $A_{LP}$ ,  $A_{NOTCH} = 1$ :

FOR  $\omega_z = \omega_0$ :  $R8 = R9 = R10$

FOR  $\omega_z < \omega_0$ :  $R9 = R10$

$$R8 = \frac{\omega_0^2}{\omega_z^2} R10$$

FOR  $\omega_z > \omega_0$ :  $R8 = R10$

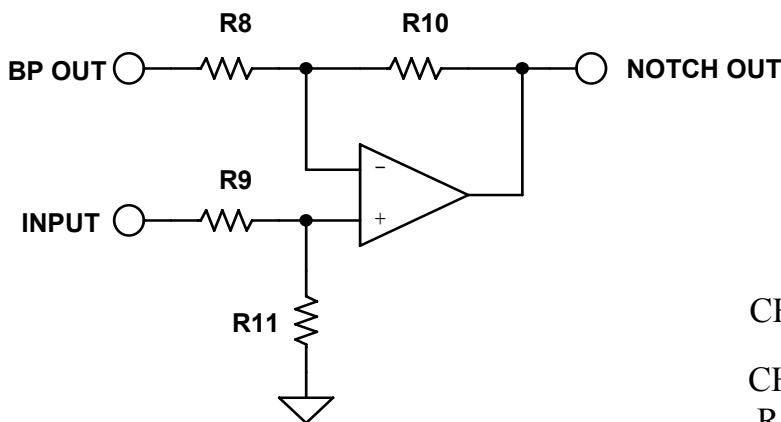

$$R9 = \frac{\omega_z^2}{\omega_0^2} R10$$

CHOOSE  $A_{NOTCH} = 1$ :

CHOOSE R10:

$$R8 = R9 = R11 = R10$$

*Figure 8.73B: State Variable Design Equations*

## STATE VARIABLE (C)

ALLPASS

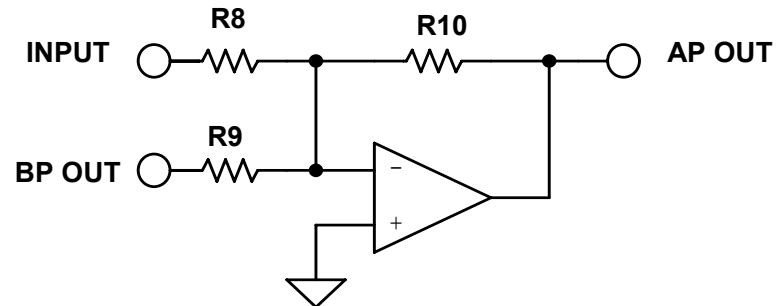

$$H = 1$$

$$R8 = R10$$

$$R9 = R8/2$$

*Figure 7-73C: State Variable Design Equations*

## BIQUADRATIC (A)

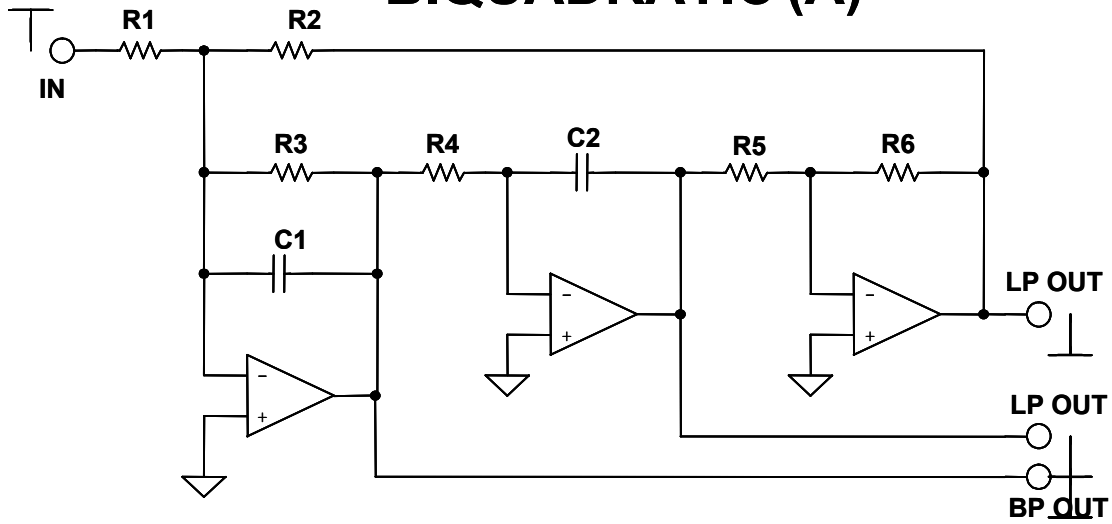

CHOOSE C, R2, R5

$$K = 2 \pi f_0 C$$

$$C1 = C2 = C$$

$$R1 = \frac{R2}{H}$$

$$R3 = \frac{1}{k \alpha}$$

$$R4 = \frac{1}{k^2 R2}$$

$$R5 = R6$$

## HIGHPASS

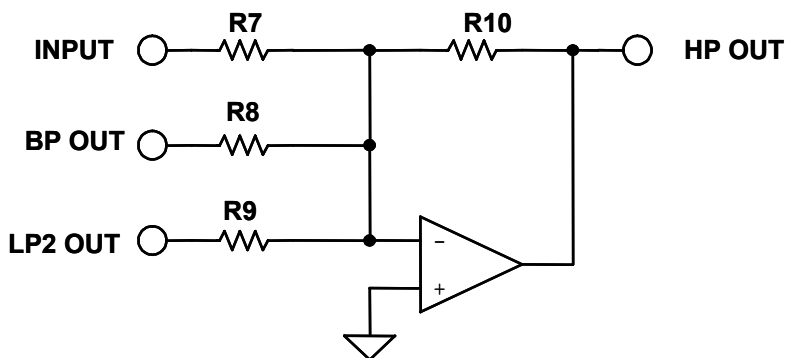

$$R7 = R8 = R9 = R$$

$$R10 = \frac{R}{H}$$

Figure 8.74A: Biquad Design Equations

## BIQUADRATIC (B)

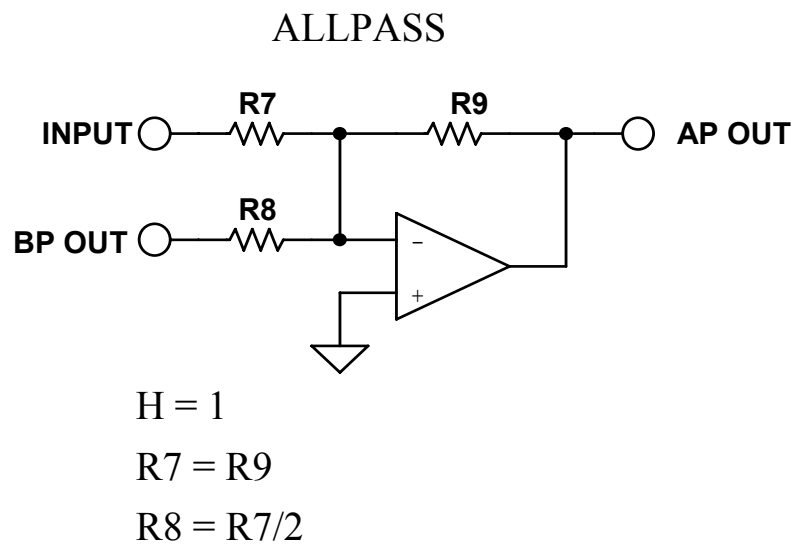
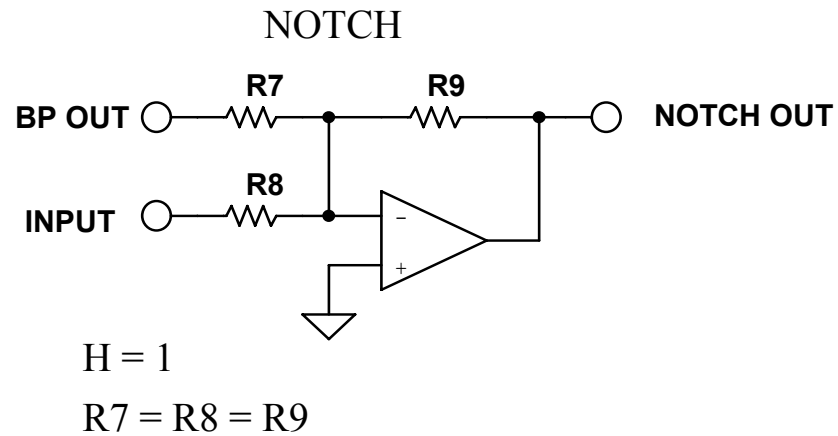
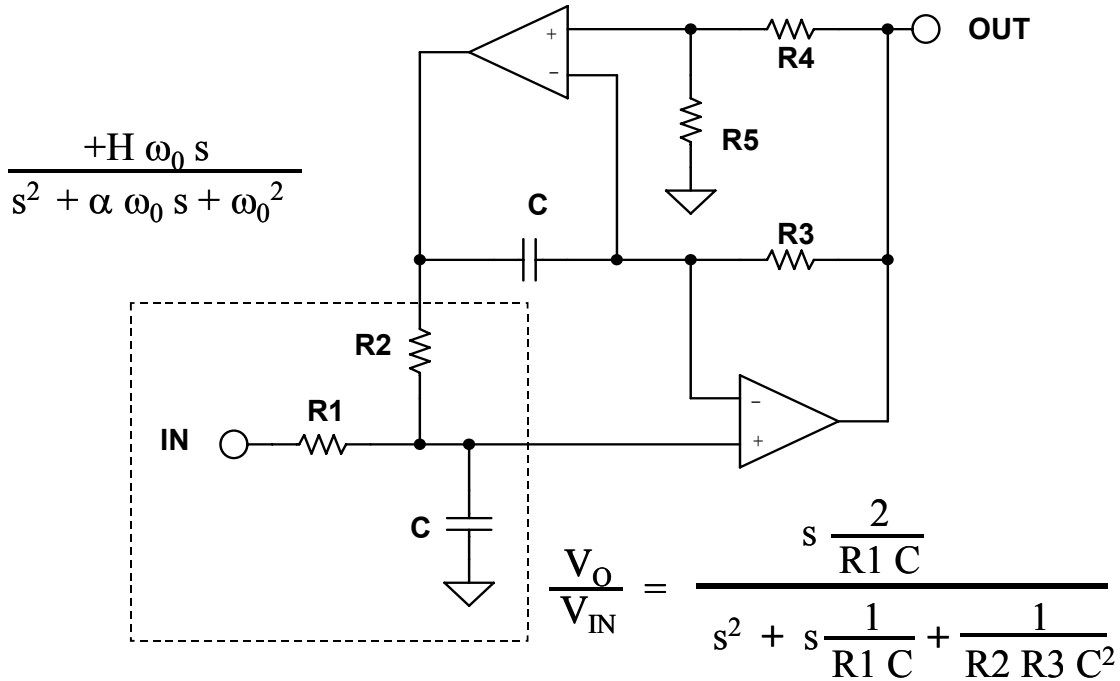

Figure 8.74B: Biquad Design Equations

## DUAL AMPLIFIER BANDPASS



CHOOSE: C R4

THEN:

$$R = \frac{1}{2 \pi F_0 C} \quad R_5 = R_4$$

$$R_1 = Q R$$

$$R_2 = R_3 = R$$

FOR GAINS LESS THAN 2 (GAIN =  $A_V$ ):

$$R_{1A} = \frac{2R_1}{A_V}$$

$$R_{1B} = \frac{R_{1A} A_V}{2 - A_V}$$

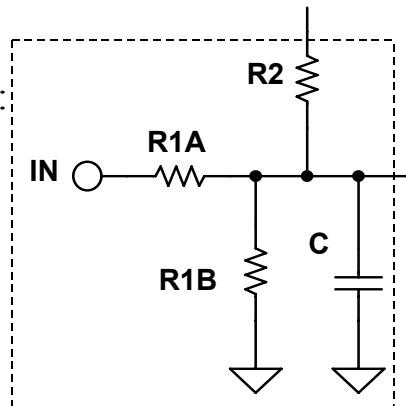
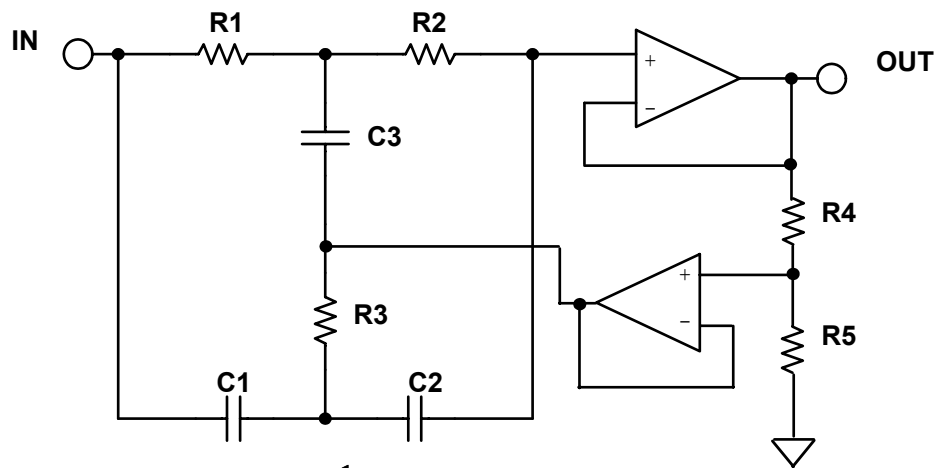

Figure 8.75: Dual Amplifier Band-Pass Design Equations



## TWIN T NOTCH



$$\frac{V_0}{V_{IN}} = \frac{s^2 + \frac{1}{RC}}{s^2 + \frac{1}{RC} + 4 \left(1 - \frac{R5}{R4 + R5}\right) s + \frac{1}{RC}} \cdot \frac{s^2 + \omega_0^2}{s^2 + 4\omega_0(1-K)s + \omega_0^2}$$

CHOOSE: C R'

$$k = 2\pi F_0 C$$

$$R4 = (1 - K) R'$$

$$R = \frac{1}{k}$$

$$R5 = K R'$$

$$R = R1 = R2 = 2 R3$$

$$C = C1 = C2 = \frac{C3}{2}$$

$$K = 1 - \frac{1}{4Q}$$

$$F_0 = \frac{1}{2\pi RC}$$

for  $K = 1$ , eliminate  $R4$  and  $R5$

(i.e.  $R5 \rightarrow 0$ ,  $Q \rightarrow \infty$ )

for  $R \gg R4$ , eliminate buffer

Figure 8.76: Twin-T Notch Design Equations

## BAINTER NOTCH

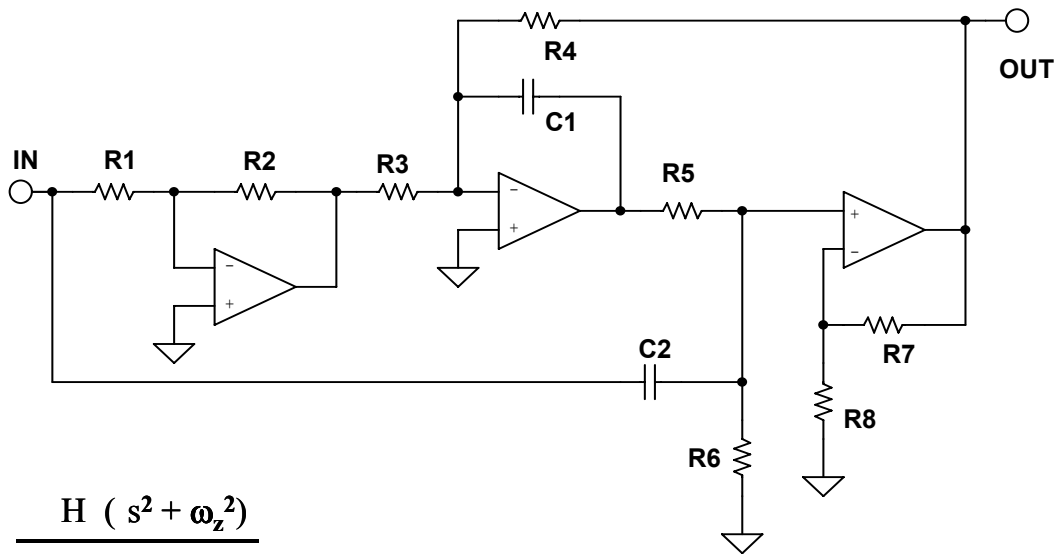

$$\frac{H (s^2 + \omega_z^2)}{s^2 + \frac{\omega_0}{Q}s + \omega_0^2}$$

$$\frac{V_{OUT}}{V_{IN}} = \frac{K2 * \left[ S^2 + \frac{K1}{R3 R5 C1 C2} \right]}{s^2 + \frac{(R5 + R6)}{R5 R6 C2} s + \frac{K2}{R4 R5 C1 C2}}$$

CHOOSE C1, R1, R7, K1, K2

$$C2 = C1 = C$$

$$k = 2 \pi F_0 C$$

$$R2 = K1 * R1$$

$$Z = \left( \frac{\omega_z}{\omega_0} \right)^2$$

$$R3 = \frac{K1}{2 Z Q k}$$

$$R4 = \frac{K2}{2 Q k}$$

$$R5 = R6 = \frac{2 Q}{k}$$

$$R8 = (K2 - 1) R7$$

Figure 8.77: Bainter Notch Design Equations

## BOCTOR NOTCH LOWPASS

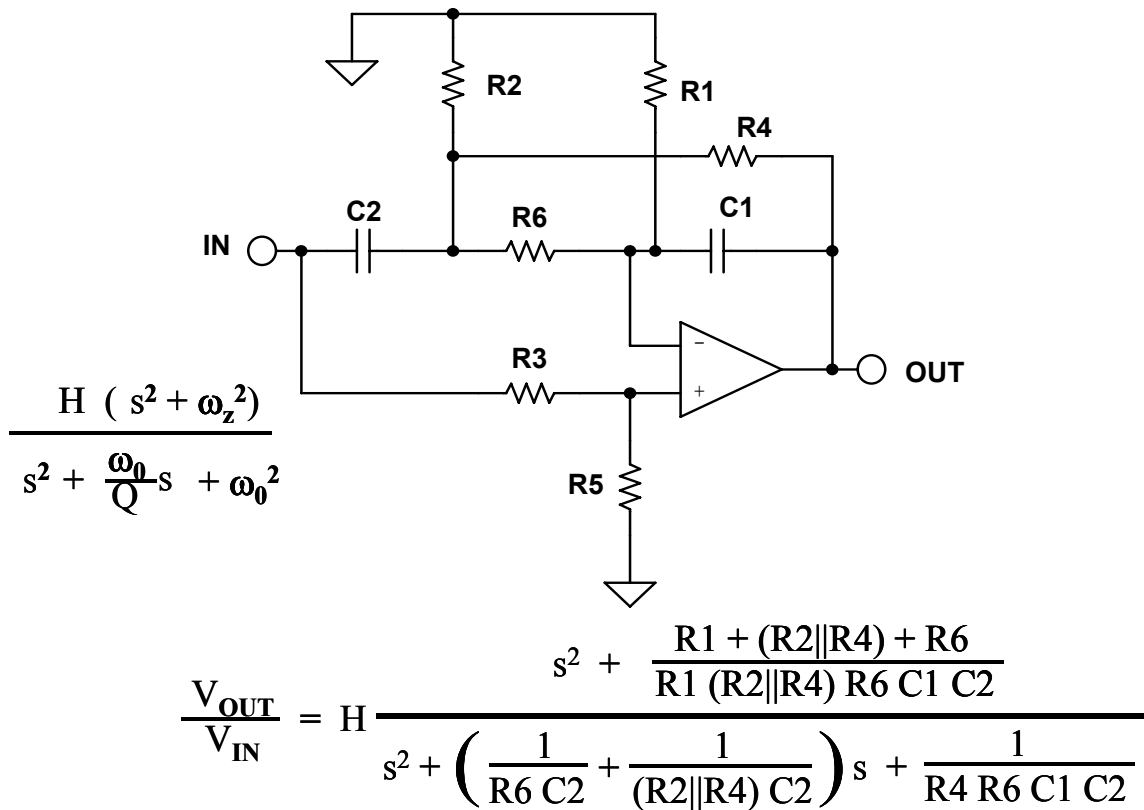

GIVEN  $\omega_0, \omega_z, Q_0$

CHOOSE  $R6, R5, C1$

$$R4 = \frac{1}{\omega_0 C1 2Q_0}$$

$$R3 = \left( \frac{R6}{R1} + 2 \frac{C1}{C2} \right) R5$$

$$R2 = \frac{R4 R6}{R4 = R6}$$

$$C2 = 4 Q_0^2 \frac{R4}{R6} C1$$

$$R1 = \frac{1}{2} \left( \frac{R6}{R4} \frac{\omega_z^2}{\omega_0^2} - 1 \right)$$

Figure 8.78: Boctor Notch, Low-Pass, Design Equations

## BOCTOR NOTCH

HIGHPASS (A)

$$\frac{H (s^2 + \omega_z^2)}{s^2 + \frac{\omega_0}{Q}s + \omega_0^2}$$

$$Q < \frac{1}{1 - \frac{F_z^2}{F_0^2}}$$

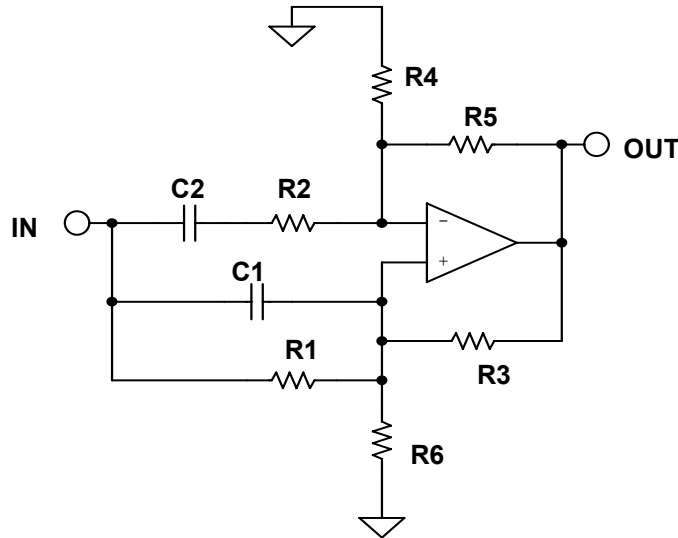

$$\frac{V_{OUT}}{V_{IN}} = \frac{\left(1 + \frac{R_5}{R_4}\right) \left(s^2 + \frac{1}{R_1 R_2 C_1 C_2}\right)}{s^2 + \left[\frac{1}{R_{EQ1} C_1} \left(1 - \frac{R_{EQ1} R_{EQ2}}{R_1 R_2}\right)\right] s + \frac{1}{R_{EQ1} R_{EQ2} C_1 C_2}}$$

WHERE:  $R_{EQ1} = R_1 \parallel R_3 \parallel R_6$   
 $R_{EQ2} = R_2 + (R_4 \parallel R_5)$

GIVEN:  $F_z F_0 H$  or  $F_z Q H$

$$Q = \frac{1}{\sqrt{2 \left(\frac{F_z^2}{F_0^2} - 1\right)}}$$

$$F_0 = F_z \sqrt{\frac{1}{1 - \frac{1}{2Q^2}}}$$

$$Y = \frac{1}{Q \left(1 - \frac{F_z^2}{F_0^2}\right)}$$

Figure 8.79A: Boctor Notch, High-Pass, Design Equations

# BOCTOR NOTCH

## HIGHPASS (B)

GIVEN: C, R2, R3

$$C1 = C2 = C$$

$$R_{EQ1} = \frac{1}{C Y 2\pi F_0}$$

$$R_{EQ2} = Y^2 R_{EQ1}$$

$$R4 = R_{EQ2} - R2 \left( \frac{H}{H-1} \right)$$

$$R5 = (H-1) R4$$

$$R1 = \frac{1}{(2\pi F_0)^2 R2 C^2}$$

$$R6 = R_{EQ1}$$

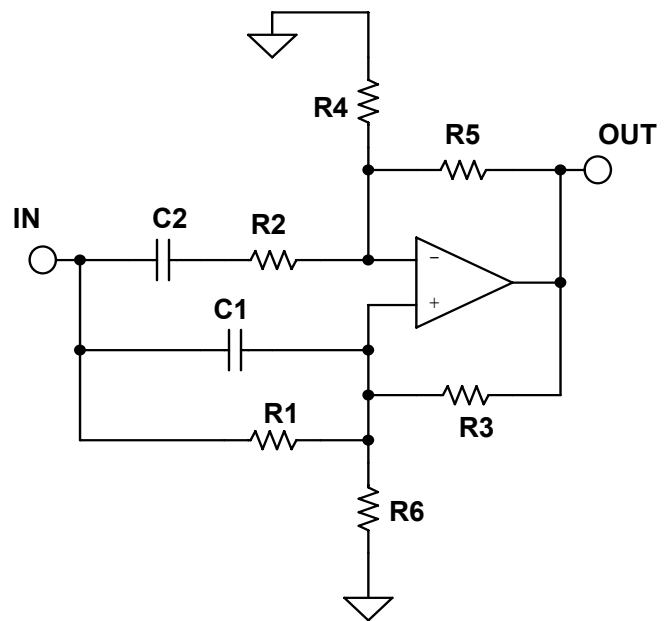

**Figure 8.79-B:** Boctor Notch, High-Pass, Design Equations (continued)

## FIRST ORDER ALLPASS

$$\frac{V_O}{V_{IN}} = \frac{s - \frac{1}{RC}}{s + \frac{1}{RC}}$$

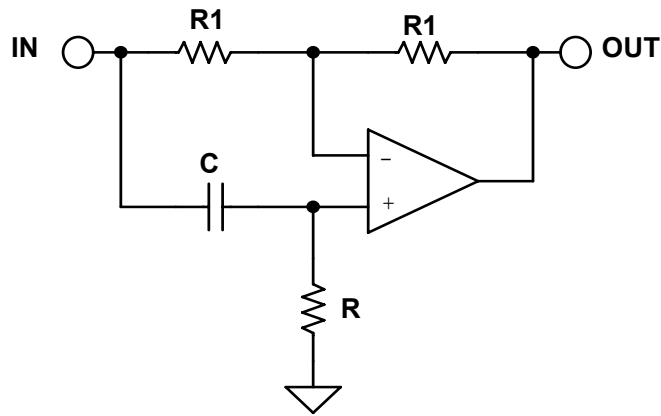

$$\text{PHASE SHIFT } (\phi) = -2 \text{ TAN}^{-1} \left( \frac{RC}{2 \pi F} \right)$$

$$\text{GROUP DELAY} = \frac{2RC}{(2 \pi F RC)^2 + 1}$$

$$\text{DELAY AT DC} = 2RC$$

GIVEN A PHASE SHIFT OF  $\phi$  AT A FREQUENCY = F

$$RC = 2 \pi F \text{ TAN} \left( -\frac{\phi}{2} \right)$$

DESIGN AS ABOVE EXCEPT  
THE SIGN OF THE PHASE CHANGES

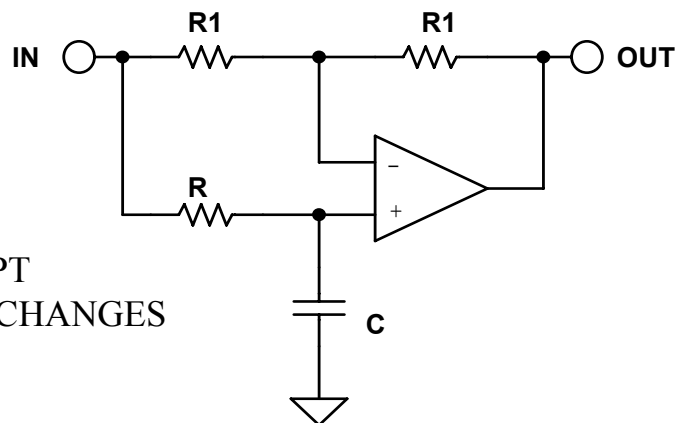
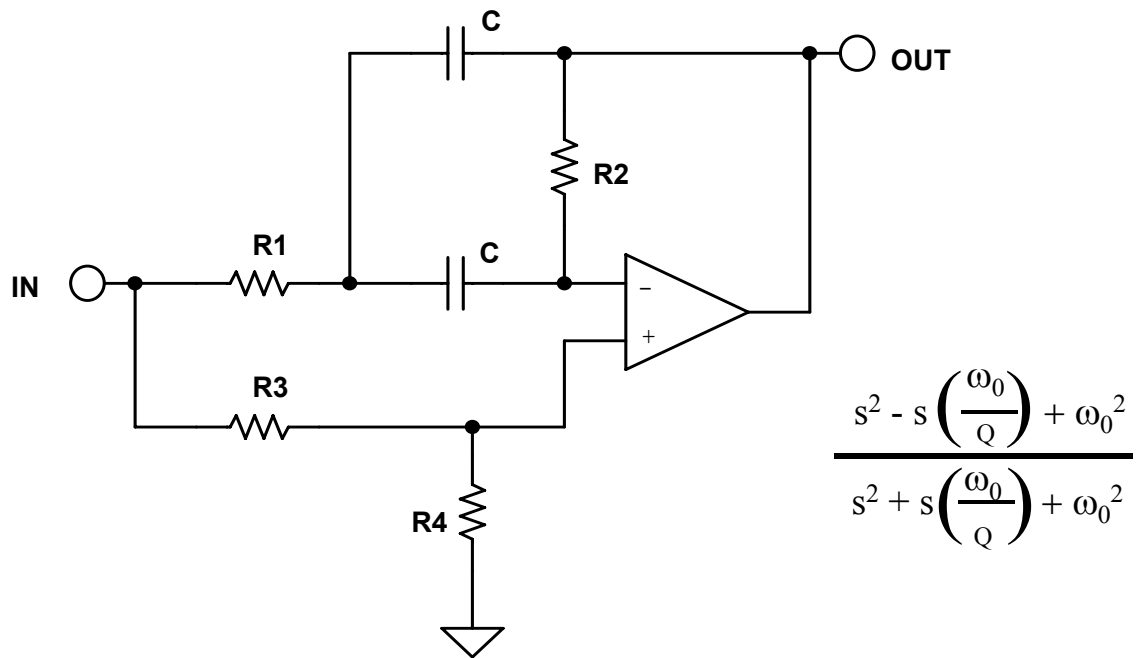

Figure 8.80: First Order All-Pass Design Equations

## SECOND ORDER ALLPASS



$$\frac{s^2 - s \left( \frac{\omega_0}{Q} \right) + \omega_0^2}{s^2 + s \left( \frac{\omega_0}{Q} \right) + \omega_0^2}$$

$$\frac{V_0}{V_{IN}} = \frac{s^2 - s \left( \frac{2}{R_2 C} \right) + \frac{1}{R_1 R_2 C^2}}{s^2 + s \left( \frac{2}{R_2 C} \right) + \frac{1}{R_1 R_2 C^2}}$$

CHOOSE: C

$$k = 2 \pi F_0 C$$

$$R_2 = \frac{2 Q}{k}$$

$$R_1 = \frac{1}{2 k Q}$$

$$R_3 = R_1$$

$$R_4 = \frac{Q}{2}$$

Figure 8.81: Second Order All-Pass Design Equation

## ▣ BASIC LINEAR DESIGN

*Notes:*



## SECTION 8.7: PRACTICAL PROBLEMS IN FILTER IMPLEMENTATION

In the previous sections filters were dealt with as mathematical functions. The filter designs were assumed to have been implemented with "perfect" components. When the filter is built with real-world components design tradeoffs must typically be made.

In building a filter with an order greater than two, multiple second and/or first order sections are used. The frequencies and Qs of these sections must align precisely or the overall response of the filter will be affected. For example, the antialiasing filter design example in the next section is a 5<sup>th</sup>-order Butterworth filter, made up of a second order section with a frequency ( $F_o$ ) = 1 and a  $Q = 1.618$ , a second order section with a frequency ( $F_o$ ) = 1 and a  $Q = 0.618$ , and a first order section with a frequency ( $F_o$ ) = 1 (for a filter normalized to 1 rad/sec). If the Q or frequency response of any of the sections is off slightly, the overall response will deviate from the desired response. It may be close, but it won't be exact. As is typically the case with engineering, a decision must be made as to what tradeoffs should be made. For instance, do we really need a particular response exactly? Is there a problem if there is a little more ripple in the pass-band? Or if the cutoff frequency is at a slightly different frequency? These are the types of questions that face a designer, and will vary from design to design.

### Passive Components (Resistors, Capacitors, Inductors)

Passive components are the first problem. When designing filters, the calculated values of components will most likely not be available commercially. Resistors, capacitors, and inductors come in standard values. While custom values can be ordered, the practical tolerance will probably still be  $\pm 1\%$  at best. An alternative is to build the required value out of a series and/or parallel combination of standard values. This increases the cost and size of the filter. Not only is the cost of components increased, so are the manufacturing costs, both for loading and tuning the filter. Furthermore, success will be still limited by the number of parts that are used, their tolerance, and their tracking, both over temperature and time.

A more practical way is to use a circuit analysis program to determine the response using standard values. The program can also evaluate the effects of component drift over temperature. The values of the sensitive components are adjusted using parallel combinations where needed, until the response is within the desired limits. Many of the higher end filter CAD programs include this feature.

The resonant frequency and Q of a filter are typically determined by the component values. Obviously, if the component value is drifting, the frequency and the Q of the filter will drift which, in turn, will cause the frequency response to vary. This is especially true in higher order filters.

## ▣ BASIC LINEAR DESIGN

Higher order implies higher Q sections. Higher Q sections means that component values are more critical, since the Q is typically set by the ratio of two or more components, typically capacitors.

In addition to the initial tolerance of the components, you must also evaluate effects of temperature/time drift. The temperature coefficients of the various components may be different in both magnitude and sign. Capacitors, especially, are difficult in that not only do they drift, but the temperature coefficient (TC) is also a function of temperature, as shown in Figure 8.82. This represents the temperature coefficient of a (relatively) poor film capacitor, which might be typical for a polyester or polycarbonate type. *Linear TC* in film capacitors can be found in the polystyrene, polypropylene, and Teflon dielectrics. In these types TC is on the order of 100 ppm/°C to 200 ppm/°C, and if necessary, this can be compensated with a complementary TC elsewhere in the circuit.

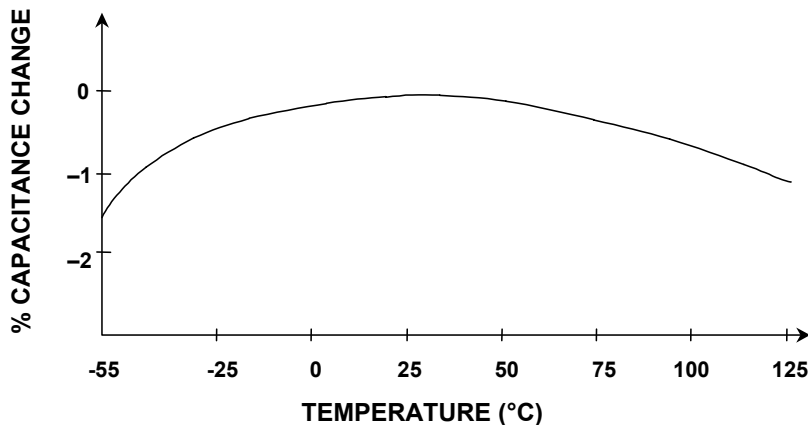

**Figure 8.82: A Poor Film Capacitor Temperature Coefficient**

The lowest TC dielectrics are NPO (or COG) ceramic ( $\pm 30$  ppm/°C), and polystyrene ( $-120$  ppm/°C). Some capacitors, mainly the plastic film types, such as polystyrene and polypropylene, also have a limited temperature range.

While there is infinite choice of the values of the passive components for building filters, in practice there are physical limits. Capacitor values below 10 pF and above 10  $\mu$ F are not practical. Electrolytic capacitors should be avoided. Electrolytic capacitors are typically very leaky. A further potential problem is if they are operated without a polarizing voltage, they become nonlinear when the ac voltage reverse biases them. Even with a dc polarizing voltage, the ac signal can reduce the instantaneous voltage to 0 V or below. Large values of film capacitors are physically very large.

Resistor values of less than 100  $\Omega$  should be avoided, as should values over 1 M $\Omega$ . Very low resistance values (under 100  $\Omega$ ) can require a great deal of drive current and dissipate a great deal of power. Both of these should be avoided. And low values and very large values of resistors may not be as readily available. Very large values tend to be more prone to parasitics since smaller capacitances will couple more easily into larger impedance levels. Noise also increases with the square root of the resistor value. Larger

**ANALOG FILTERS**  
**PRACTICAL PROBLEMS IN FILTER IMPLEMENTATION**

value resistors also will cause larger offsets due to the effects of the amplifier bias currents.

Parasitic capacitances due to circuit layout and other sources affect the performance of the circuit. They can form between two traces on a PC board (on the same side or opposite side of the board), between leads of adjacent components, and just about everything else you can (and in most cases can't) think of. These capacitances are usually small, so their effect is greater at high impedance nodes. Thus, they can be controlled most of the time by keeping the impedance of the circuits down. Remember that the effects of stray capacitance are frequency dependent, being worse at high frequencies because the impedance drops with increasing frequency.

Parasitics are not just associated with outside sources. They are also present in the components themselves.

A capacitor is more than just a capacitor in most instances. A real capacitor has inductance (from the leads and other sources) and resistance as shown in Figure 8.83. This resistance shows up in the specifications as leakage and poor power factor. Obviously, we would like capacitors with very low leakage and good power factor (see Figure 8.84).

In general, it is best to use plastic film (preferably Teflon or polystyrene) or mica capacitors and metal film resistors, both of moderate to low values in our filters.

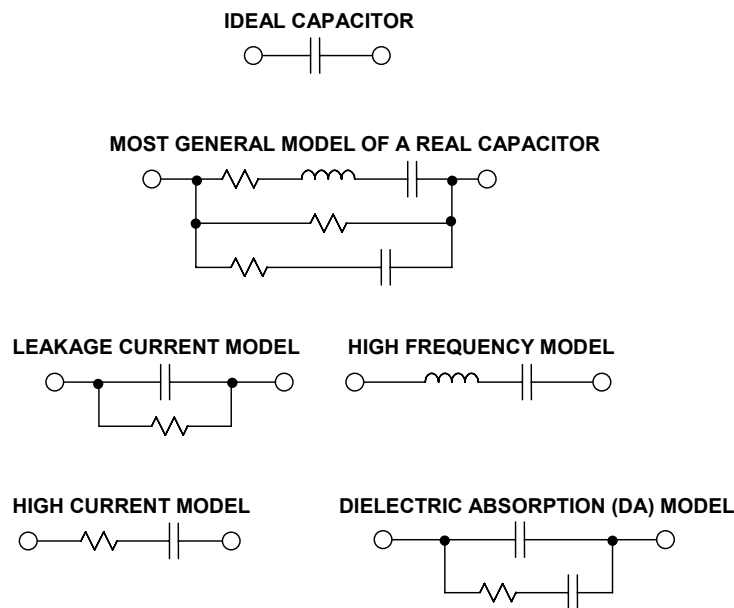

**Figure 8.83: Capacitor Equivalent Circuit**

One way to reduce component parasitics is to use surface mounted devices. Not having leads means that the lead inductance is reduced. Also, being physically smaller allows more optimal placement. A disadvantage is that not all types of capacitors are available in surface mount. Ceramic capacitors are popular surface mount types, and of these, the NPO family has the best characteristics for filtering. Ceramic capacitors may also be prone to microphonics. Microphonics occurs when the capacitor turns into a motion

## ▣ BASIC LINEAR DESIGN

sensor, similar to a strain gauge, and turns vibration into an electrical signal, which is a form of noise.

Resistors also have parasitic inductances due to leads and parasitic capacitance. The various qualities of resistors are compared in Figure 8.85

### RESISTOR COMPARISON CHART

	TYPE	ADVANTAGES	DISADVANTAGES
<b>DISCRETE</b>	Carbon Composition	Lowest Cost High Power/Small Case Size Wide Range of Values	Poor Tolerance (5%) Poor Temperature Coefficient (1500 ppm/°C)
	Wirewound	Excellent Tolerance (0.01%) Excellent TC (1 ppm/°C) High Power	Reactance is a Problem Large Case Size Most Expensive
	Metal Film	Good Tolerance (0.1%) Good TC (<1 to 100 ppm/°C) Moderate Cost Wide Range of Values Low Voltage Coefficient	Must be Stabilized with Burn-In Low Power
	Bulk Metal or Metal Foil	Excellent Tolerance (to 0.005%) Excellent TC (to <1 ppm/°C) Low Reactance Low Voltage Coefficient	Low Power Very Expensive
	High Mega Ohm	Very High Values ( $10^8 \Omega$ to $10^{14} \Omega$ ) Only Choice for Some Circuits	High Voltage Coefficient (200 ppm/V) Fragile Glass Case (Needs Special Handling) Expensive
<b>NETWORKS</b>	Thick Film	Low Cost High Power Laser-Trimable Readily Available	Fair Matching (0.1%) Poor TC (>100 ppm/°C) Poor Tracking TC (10 ppm/°C)
	Thin Film	Good Matching (<0.01%) Good TC (<100 ppm/°C) Good Tracking TC (2 ppm/°C) Moderate Cost Laser-Trimable Low Capacitance Suitable for Hybrid IC Substrate	Often Large Geometry Limited Values and Configurations

**Figure 8.84:** Resistor Comparison Chart

### CAPACITOR COMPARISON CHART

TYPE	TYPICAL DA	ADVANTAGES	DISADVANTAGES
Polystyrene	0.001% to 0.02%	Inexpensive Low DA Good stability (~120ppm/°C)	Damaged by temperature > +85°C Large High inductance Vendors limited
Polypropylene	0.001% to 0.02%	Inexpensive Low DA Stable (~200ppm/°C) Wide range of values	Damaged by temperature > +105°C Large High inductance
Teflon	0.003% to 0.02%	Low DA available Good stability Operational above +125 °C Wide range of values	Expensive Large High inductance
Polycarbonate	0.1%	Good stability Low cost Wide temperature range Wide range of values	Large DA limits to 8-bit applications High inductance
Polyester	0.3% to 0.5%	Moderate stability Low cost Wide temperature range Low inductance (stacked film)	Large DA limits to 8-bit applications High inductance (conventional)
NP0 Ceramic	<0.1%	Small case size Inexpensive, many vendors Good stability (30ppm/°C) 1% values available Low inductance (chip)	DA generally low (may not be specified) Low maximum values ( 10nF)
Monolithic Ceramic (High K)	>0.2%	Low inductance (chip) Wide range of values	Poor stability Poor DA High voltage coefficient
Mica	>0.003%	Low loss at HF Low inductance Good stability 1% values available	Quite large Low maximum values ( 10nF) Expensive
Aluminum Electrolytic	Very high	Large values High currents High voltages Small size	High leakage Usually polarized Poor stability, accuracy Inductive
Tantalum Electrolytic	Very high	Small size Large values Medium inductance	High leakage Usually polarized Expensive Poor stability, accuracy

**Figure 8.85: Capacitor Comparison Chart**

## ▣ BASIC LINEAR DESIGN

### Limitations of Active Elements (Op Amps) in Filters

The active element of the filter will also have a pronounced effect on the response. In developing the various topologies (Multiple Feedback, Sallen-Key, State Variable, etc.), the active element was always modeled as a "perfect" operational amplifier. That is to say it has:

- 1) infinite gain
- 2) infinite input impedance
- 3) zero output impedance

none of which vary with frequency. While amplifiers have improved a great deal over the years, this model has not yet been realized.

The most important limitation of the amplifier has to do with its gain variation with frequency. All amplifiers are band limited. This is due mainly to the physical limitations of the devices with which the amplifier is constructed. Negative feedback theory tells us that the response of an amplifier must be first order ( $-6$  dB per octave) when the gain falls to unity in order to be stable. To accomplish this, a real pole is usually introduced in the amplifier so the gain rolls off to  $<1$  by the time the phase shift reaches  $180^\circ$  (plus some phase margin, hopefully). This roll off is equivalent to that of a single-pole filter. So in simplistic terms, the transfer function of the amplifier is added to the transfer function of the filter to give a composite function. How much the frequency dependent nature of the op amp affects the filter is dependent on which topology is used as well as the ratio of the filter frequency to the amplifier bandwidth.

The Sallen-Key configuration, for instance, is the least dependent on the frequency response of the amplifier. All that is required is for the amplifier response to be flat to just past the frequency where the attenuation of the filter is below the minimum attenuation required. This is because the amplifier is used as a gain block. Beyond cutoff, the attenuation of the filter is reduced by the rolloff of the gain of the op amp. This is because the output of the amplifier is phase shifted, which results in incomplete nulling when fed back to the input. There is also an issue with the output impedance of the amplifier rising with frequency as the open loop gain rolls off. This causes the filter to lose attenuation.

The state variable configuration uses the op amps in two modes, as amplifiers and as integrators. As amplifiers, the constraint on frequency response is basically the same as for the Sallen-Key, which is flat out to the minimum attenuation frequency. As an integrator, however, more is required. A good rule of thumb is that the open-loop gain of the amplifier must be greater than 10 times the closed-loop gain (including peaking from the Q of the circuit). This should be taken as the absolute minimum requirement. What this means is that there must be 20 dB loop gain, minimum. Therefore, an op amp with 10 MHz unity gain bandwidth is the minimum required to make a 1 MHz integrator. What happens is that the effective Q of the circuit increases as loop gain decreases. This phenomenon is called Q enhancement. The mechanism for Q enhancement is similar to that of slew rate limitation. Without sufficient loop gain, the op amp virtual ground is no

longer at ground. In other words, the op amp is no longer behaving as an op amp. Because of this, the integrator no longer behaves like an integrator.

The multiple feedback configuration also places heavy constraints on the active element. Q enhancement is a problem in this topology as well. As the loop gain falls, the Q of the circuit increases, and the parameters of the filter change. The same rule of thumb as used for the integrator also applies to the multiple feedback topology (loop gain should be at least 20 dB). The filter gain must also be factored into this equation.

In the FDNR realization, the requirements for the op amps are not as clear. To make the circuit work, we assume that the op amps will be able to force the input terminals to be the same voltage. This implies that the loop gain be a minimum of 20 dB at the resonant frequency.

Also it is generally considered to be advantageous to have the two op amps in each leg matched. This is easily accomplished using dual op amps. It is also a good idea to have low bias current devices for the op amps, so FET input op amps should be used, all other things being equal.

In addition to the frequency dependent limitations of the op amp, several others of its parameters may be important to the filter designer.

One is input impedance. We assume in the "perfect" model that the input impedance is infinite. This is required so that the input of the op amp does not load the network around it. This means that we probably want to use FET amplifiers with high impedance circuits.

There is also a small frequency dependent term to the input impedance, since the effective impedance is the real input impedance multiplied by the loop gain. This usually is not a major source of error, since the network impedance of a high frequency filter should be low.

### **Distortion Resulting from Input Capacitance Modulation**

Another subtle effect can be noticed with FET input amps. The input capacitance of a FET changes with the applied voltage. When the amplifier is used in the inverting configuration, such as with the multiple feedback configuration, the applied voltage is held to 0 V. Therefore there is no capacitance modulation. However, when the amplifier is used in the noninverting configuration, such as in the Sallen-Key circuit, this form of distortion can exist.

There are two ways to address this issue. The first is to keep the equivalent impedance low. The second is to balance the impedance seen by the inputs. This is accomplished by adding a network into the feedback leg of the amplifier which is equal to the equivalent input impedance. Note that this will only work for a unity gain application.

## ▣ BASIC LINEAR DESIGN

As an example, which is taken from the OP176 data sheet, a 1 kHz high-pass Sallen-Key filter is shown (Figure 8.86). Figure 8.87 shows the distortion for the uncompensated version (curve A1) as well as with the compensation (curve A2). Also shown is the same circuit with the impedances scaled up by a factor of 10 (B1 uncompensated, B2 compensated). Note that the compensation improves the distortion, but not as much as having low impedance to start with.

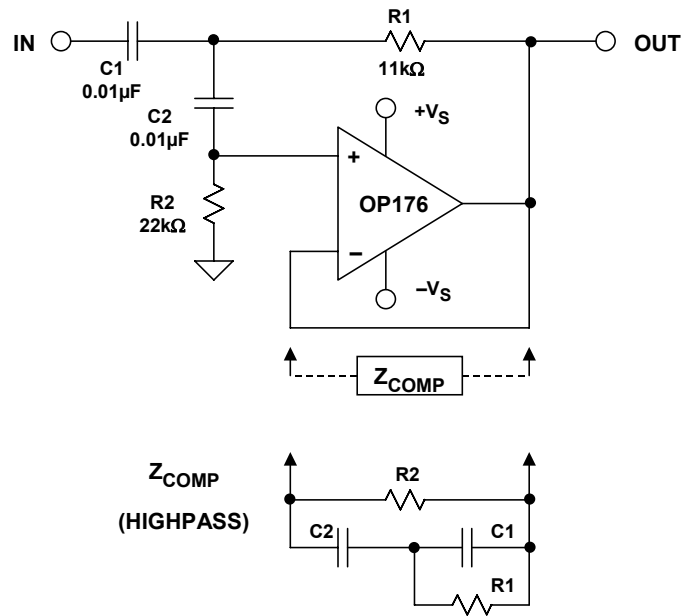

**Figure 8.86:** Compensation for Input Capacitance Voltage Modulation

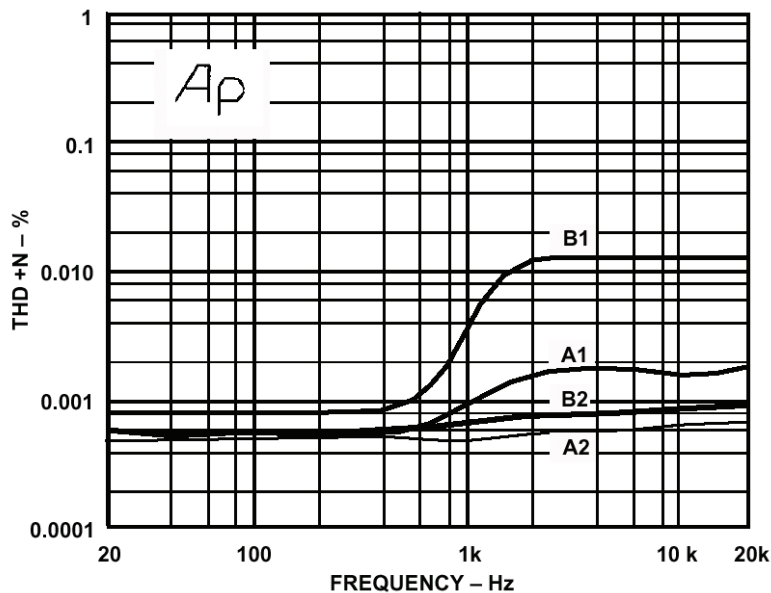

**Figure 8.87:** Distortion Due to Input Capacitance Modulation



Similarly, the op amp output impedance affects the response of the filter. The output impedance of the amplifier is divided by the loop gain, therefore the output impedance will rise with increasing frequency. This may have an effect with high frequency filters if the output impedance of the stage driving the filter becomes a significant portion of the network impedance.

The fall of loop gain with frequency can also affect the distortion of the op amp, since there is less loop gain available for correction. In the multiple feedback configuration the feedback loop is also frequency dependent, which may further reduce the feedback correction, resulting in increased distortion. This effect is counteracted somewhat by the reduction of distortion components in the filter network (assuming a low-pass or band-pass filter).

All of the discussion so far is based on using classical voltage feedback op amps. Current feedback, or transimpedance, op amps offer improved high frequency response, but are unusable in any topologies discussed except the Sallen-Key. The problem is that capacitance in the feedback loop of a current feedback amplifier usually causes it to become unstable. Also, most current feedback amplifiers will only drive a small capacitive load. Therefore, it is difficult to build classical integrators using current feedback amplifiers. Some current feedback op amps have an external pin that may be used to configure them as a very good integrator, but this configuration does not lend itself to classical active filter designs.

Current feedback integrators tend to be noninverting, which is not acceptable in the state variable configuration. Also, the bandwidth of a current feedback amplifier is set by its feedback resistor, which would make the Multiple Feedback topology difficult to implement. Another limitation of the current feedback amplifier in the Multiple Feedback configuration is the low input impedance of the inverting terminal. This would result in loading of the filter network. Sallen-Key filters are possible with current feedback amplifiers, since the amplifier is used as a noninverting gain block. New topologies that capitalize on the current feedback amplifiers superior high frequency performance and compensate for its limitations will have to be developed.

### **Q Peaking and Q Enhancement**

The last thing that you need to be aware of is exceeding the dynamic range of the amplifier.  $Q$ s over 0.707 will cause peaking in the response of the filter (see Figures 8.5 through 8.7). For high  $Q$ 's, this could cause overload of the input or output stages of the amplifier with a large input. Note that relatively small values of  $Q$  can cause significant peaking. The  $Q$  times the gain of the circuit must stay under the loop gain (plus some margin, again, 20 dB is a good starting point). This holds for multiple amplifier topologies as well. Be aware of internal node levels, as well as input and output levels. As an amplifier overloads, its effective  $Q$  decreases, so the transfer function will appear to change even if the output appears undistorted. This shows up as the transfer function changing with increasing input level.

## ▣ BASIC LINEAR DESIGN

We have been dealing mostly with low-pass filters in our discussions, but the same principles are valid for high-pass, band-pass, and band-reject as well. In general, things like Q enhancement and limited gain/bandwidth will not affect high-pass filters, since the resonant frequency will hopefully be low in relation to the cutoff frequency of the op amp. Remember, though, that the high-pass filter will have a low-pass section, by default, at the cutoff frequency of the amplifier. Band-pass and band-reject (notch) filters will be affected, especially since both tend to have high values of Q.

The general effect of the op amp's frequency response on the filter Q is shown in Figure 8.88.

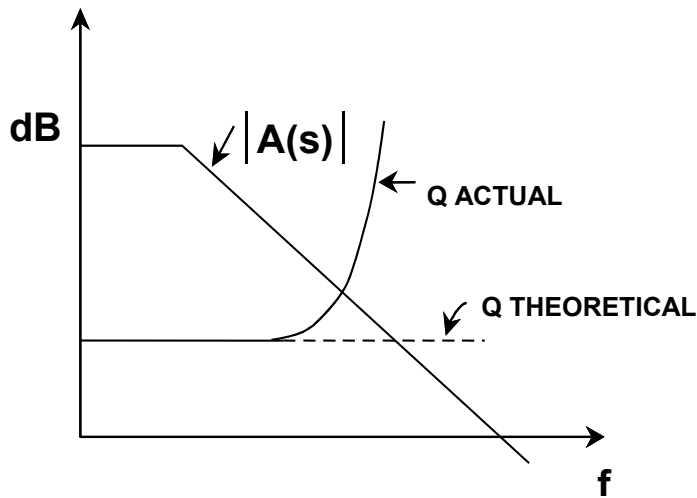

**Figure 8.88:** Q Enhancement

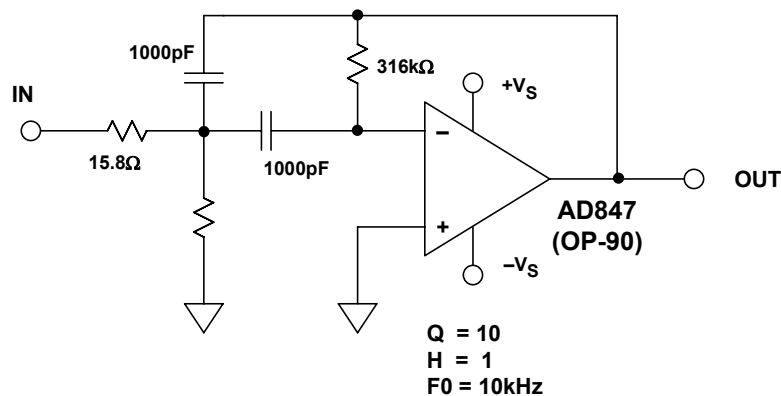

**Figure 8.89:** 1 kHz Multiple Feedback Band-Pass Filter

As an example of the Q enhancement phenomenon, consider the Spice simulation of a 10 kHz band-pass multiple feedback filter with Q = 10 and gain = 1, using a good high frequency amplifier (the AD847) as the active device. The circuit diagram is shown in Figure 8.89. The open-loop gain of the AD847 is greater than 70 dB at 10 kHz as shown

**ANALOG FILTERS**  
**PRACTICAL PROBLEMS IN FILTER IMPLEMENTATION**

in Figure 8.91(A). This is well over the 20 dB minimum, so the filter works as designed as shown in Figure 8.90.

We now replace the AD847 with an OP-90. The OP-90 is a dc precision amplifier and so has a limited bandwidth. In fact, its open-loop gain is less than 10 dB at 10 kHz (see Figure 8.91(B)). This is not to imply that the AD847 is in all cases better than the OP-90. It is a case of misapplying the OP-90.

From the output for the OP-90, also shown in Figure 8.90, we see that the magnitude of the output has been reduced, and the center frequency has shifted downward.

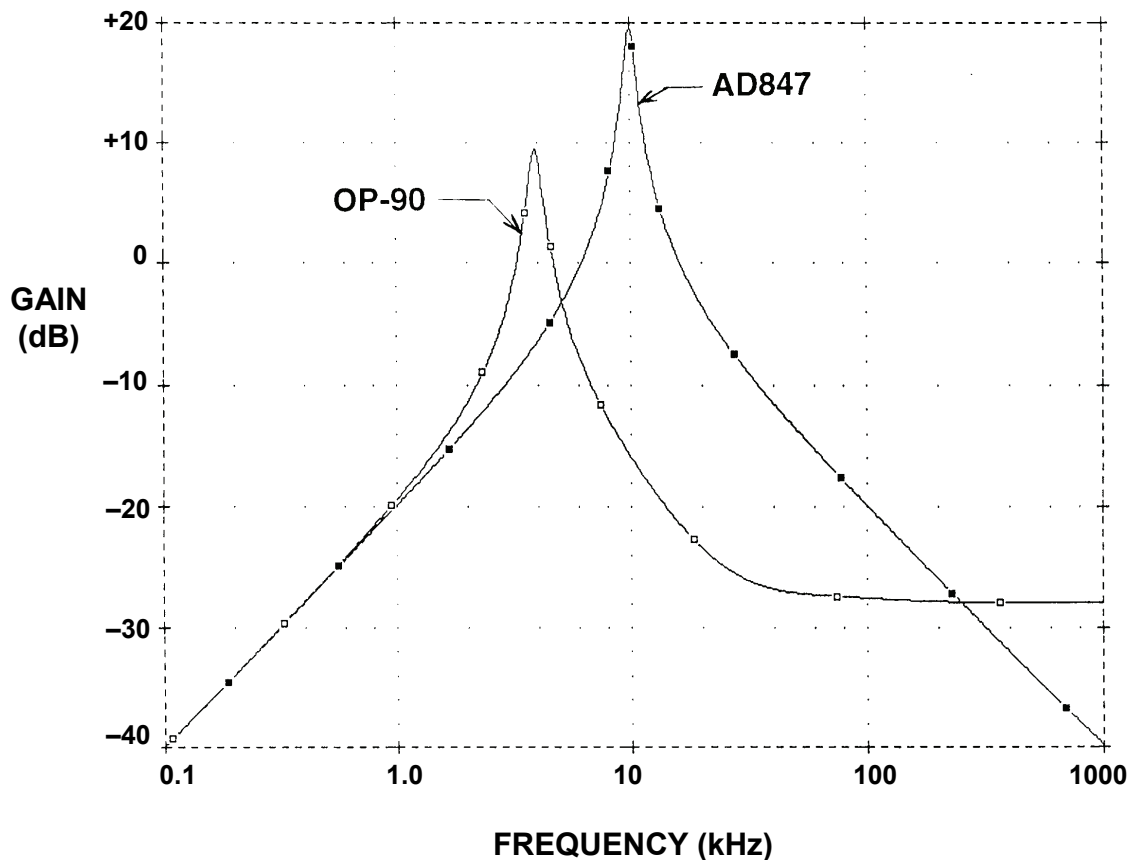

**Figure 8.90: Effects of "Q Enhancement"**

## ▣ BASIC LINEAR DESIGN

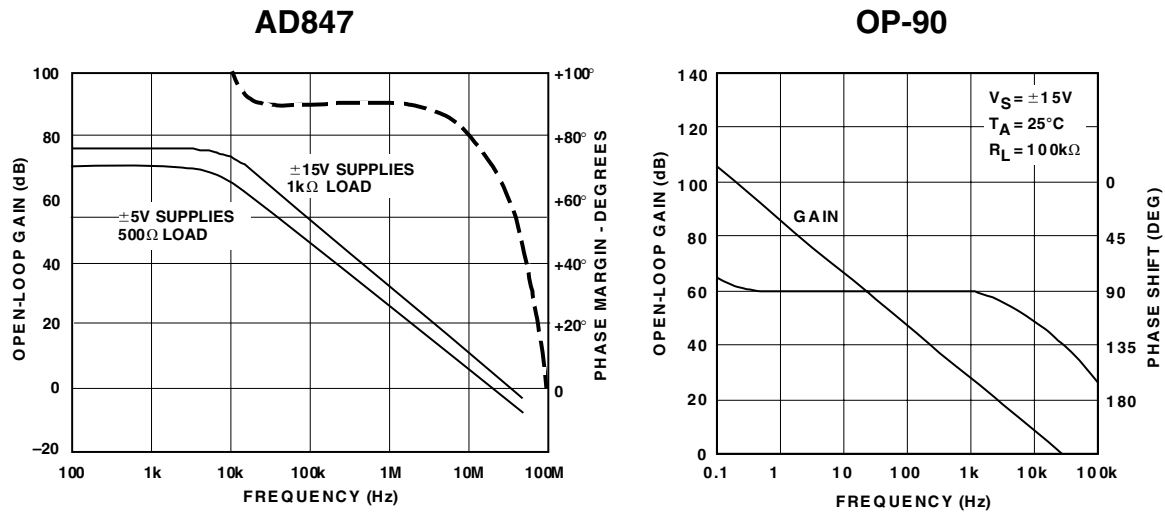

Figure 8.91: AD847 and OP-90 Bode Plots

## SECTION 8.8: DESIGN EXAMPLES

Several examples will now be worked out to demonstrate the concepts previously discussed

### Antialias Filter

As an example, passive and active antialias filters will now be designed based upon a common set of specifications. The active filter will be designed in four ways: Sallen-Key, Multiple Feedback, State Variable, and Frequency Dependent Negative Resistance (FDNR).

The specifications for the filter are given as follows:

- 1) The cutoff frequency will be 8 kHz.
- 2) The stopband attenuation will be 72 dB. This corresponds to a 12 bit system.
- 3) Nyquist frequency of 50 kSPS.
- 4) The Butterworth filter response is chosen in order to give the best compromise between attenuation and phase response.

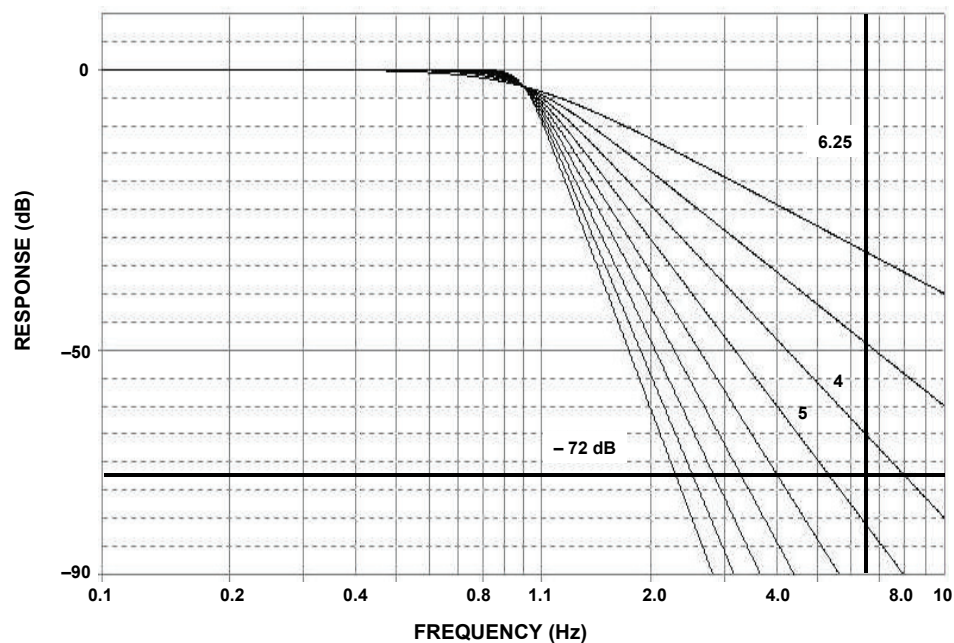

**Figure 8.92: Determining Filter Order**

## ▣ BASIC LINEAR DESIGN

Consulting the Butterworth response curves (Figure 8.14, reproduced above in Figure 8.92), we see that for a frequency ratio of 6.25 (50 kSPS/8 kSPS), that a filter order of 5 is required.

Now consulting the Butterworth design table (Figure 8.25), the normalized poles of a 5<sup>th</sup> order Butterworth filter are:

STAGE	F <sub>o</sub>	$\alpha$
1	1.000	1.618
2	1.000	0.618
3	1.000	-----

The last stage is a real (single) pole, thus the lack of an alpha value. It should be noted that this is not necessarily the order of implementation in hardware. In general, you would typically put the real pole last and put the second order sections in order of decreasing alpha (increasing Q) as we have done here. This will avoid peaking due to high Q sections possibly overloading internal nodes. Another feature of putting the single-pole at the end is to bandlimit the noise of the op amps. This is especially true if the single-pole is implemented as a passive filter.

For the passive design, we will choose the zero input impedance configuration. While "classic" passive filters are typically double terminated, that is with termination on both source and load ends, we are concerned with voltage transfer not power transfer so the source termination will not be used. From the design table (see Reference 2, p. 313), we find the normalized values for the filter (see Figure 8.93).

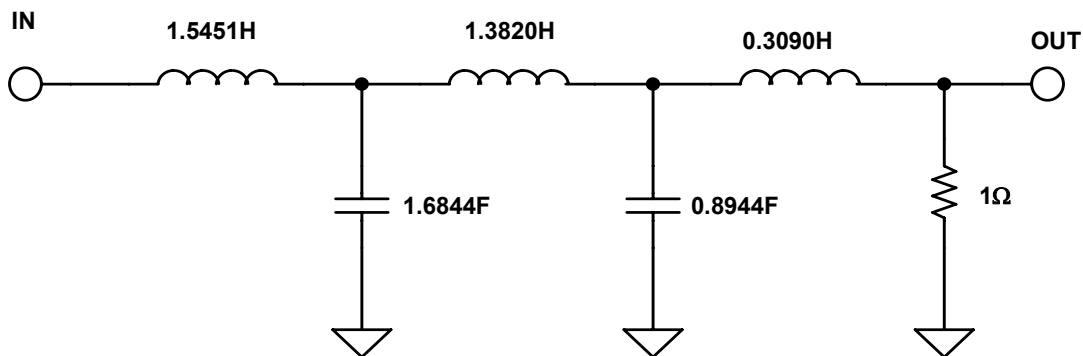
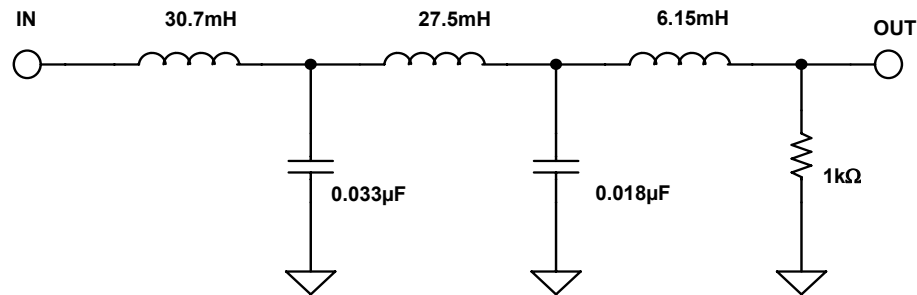

**Figure 8.93:** Normalized Passive Filter Implementation

These values are normalized for a 1 rad/s filter with a 1  $\Omega$  termination. To scale the filter we divide all reactive elements by the desired cutoff frequency, 8 kHz (= 50265 rad/sec, =  $2\pi \cdot 8 \times 10^3$ ). This is commonly referred to as the frequency scale factor (FSF). We also need to scale the impedance.

For this example, an arbitrary value of  $1000\ \Omega$  is chosen. To scale the impedance, we multiply all resistor and inductor values and divide all capacitor values by this magnitude, which is commonly referred to as the impedance scaling factor ( $Z$ ).

After scaling, the circuit looks like Figure 8.94.



**Figure 8.94: Passive Filter Implementation**

For the Sallen-Key active filter, we use the design equations shown in Figure 8.49. The values for  $C1$  in each section are arbitrarily chosen to give reasonable resistor values. The implementation is shown in Figure 8.95.

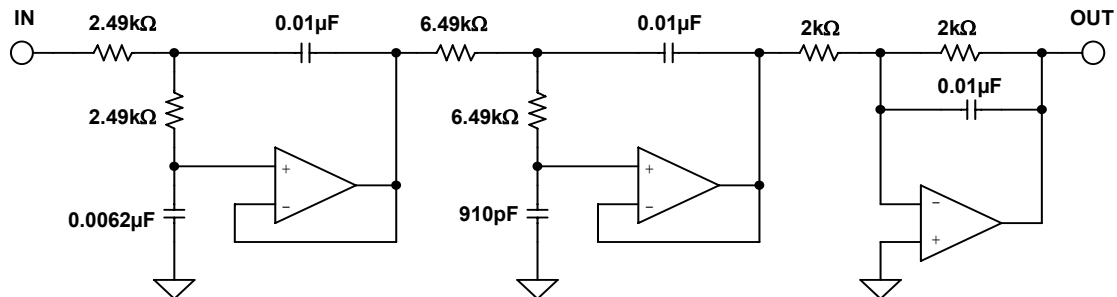

**Figure 8.95: Sallen-Key Implementation**

The exact values have been rounded to the nearest standard value. For most active realization to work correctly, it is required to have a zero-impedance driver, and a return path for dc due to the bias current of the op amp. Both of these criteria are approximately met when you use an op amp to drive the filter.

In the above example the single pole has been built as an active circuit. It would have been just as correct to configure it as a passive RC filter. The advantage to the active section is lower output impedance, which may be an advantage in some applications, notably driving an ADC input that uses a switched capacitor structure.

This type of input is common on sigma delta ADCs as well as many other CMOS type of converters. It also eliminates the loading effects of the input impedance of the following stage on the passive section.

## ▣ BASIC LINEAR DESIGN

Figure 8.96 shows a multiple feedback realization of our filter. It was designed using the equations in Figure 8.52. In this case, the last section is a passive RC circuit.

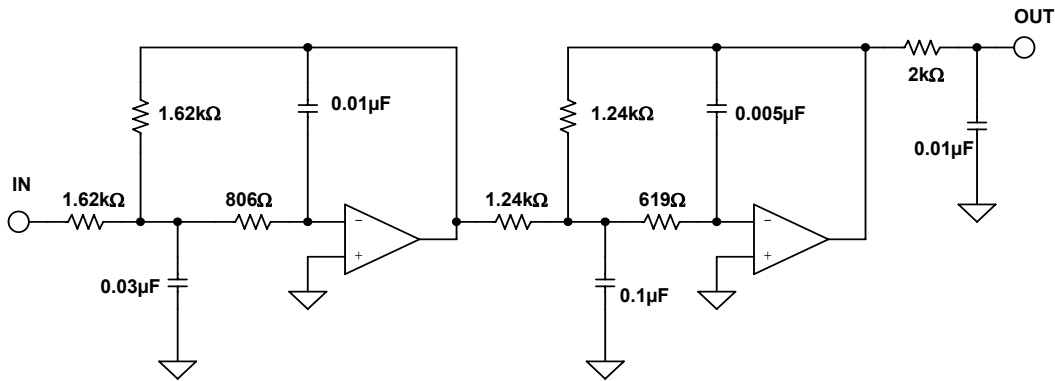

**Figure 8.96: Multiple Feedback Implementation**

An optional buffer could be added after the passive section, if desired. This would give many of the advantages outlined above, except for bandlimiting the noise of the output amp. By using one of the above two filter realizations, we have both an inverting and a noninverting design.

The state variable filter, shown in Figure 8.97, was designed with the equations in Figure 8.55. Again, we have rounded the resistor values to the nearest standard 1% value.

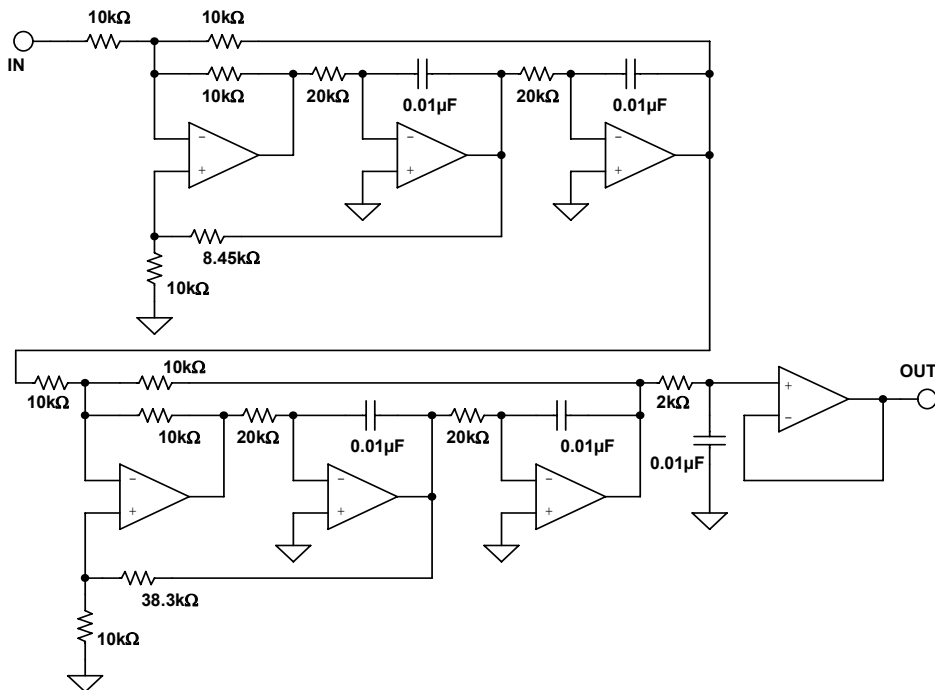
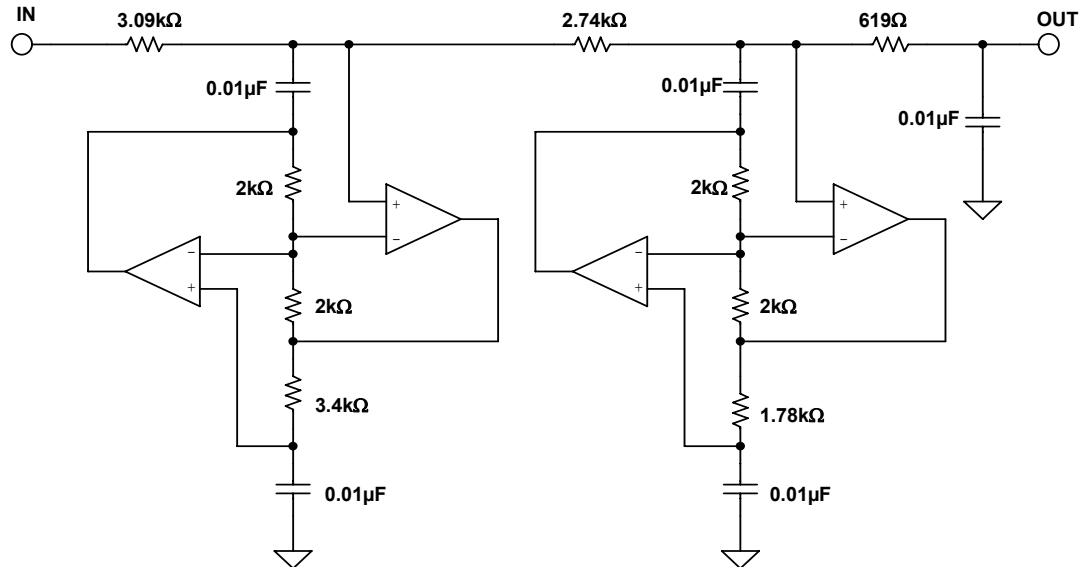

**Figure 8.97: State Variable Implementation**

Obviously this filter implementation has many more parts than either the Sallen-Key or the multiple feedback. The rationale for using this circuit is that stability is improved and the individual parameters are independently adjustable.



The Frequency Dependent Negative Resistance (FDNR) realization of this filter is shown in Figure 8.98.



**Figure 8.98: FDNR Implementation**

In the conversion process from passive to FDNR, the D element is normalized for a capacitance of 1 F. We then scale the filter to a more reasonable value (0.01  $\mu\text{F}$  in this case).

In all of the above implementations standard values were used instead of the calculated values. Any variation from the ideal values will cause a shift in the filter response characteristic, but often the effects are minimal. The computer can be used to evaluate these variations on the overall performance and determine if they are acceptable.

To examine the effect of using standard values, take the Sallen-Key implementation. Figure 8.99 shows the response of each of the 3 sections of the filter. While the Sallen-Key was the filter used, the results from any of the other implementations will give similar results.

Figure 8.100 then shows the effect of using standard values instead of calculated values. Notice that the general shape of the filter remains the same, just slightly shifted in frequency. This investigation was done only for the standard value of the resistors. To understand the total effect of component tolerance the same type of calculations would have to be done for the tolerance of all the components and also for their temperature and aging effects.

## ▣ BASIC LINEAR DESIGN

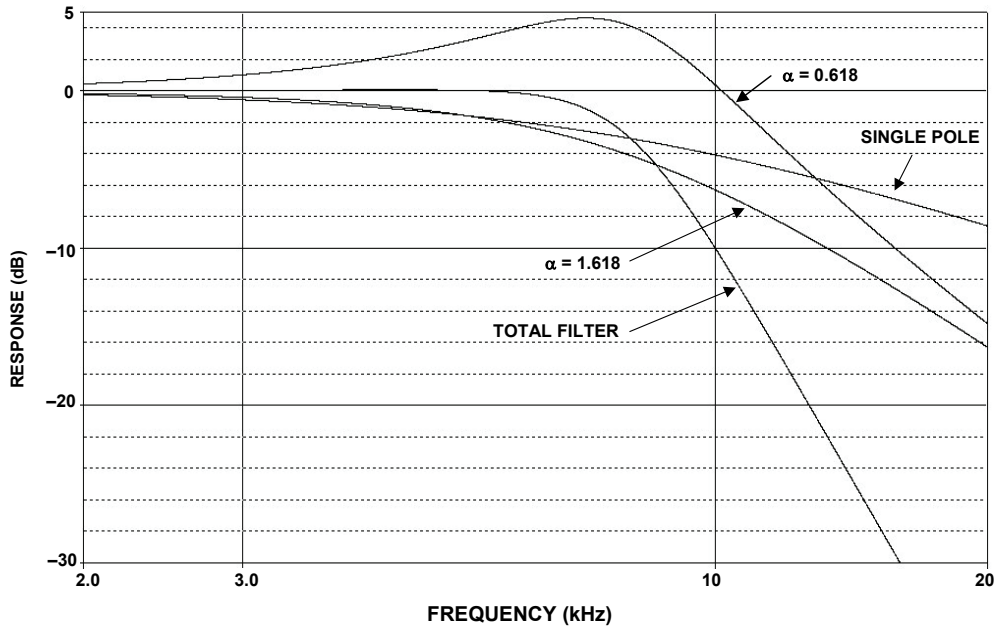

**Figure 8.99: Individual Section Response**

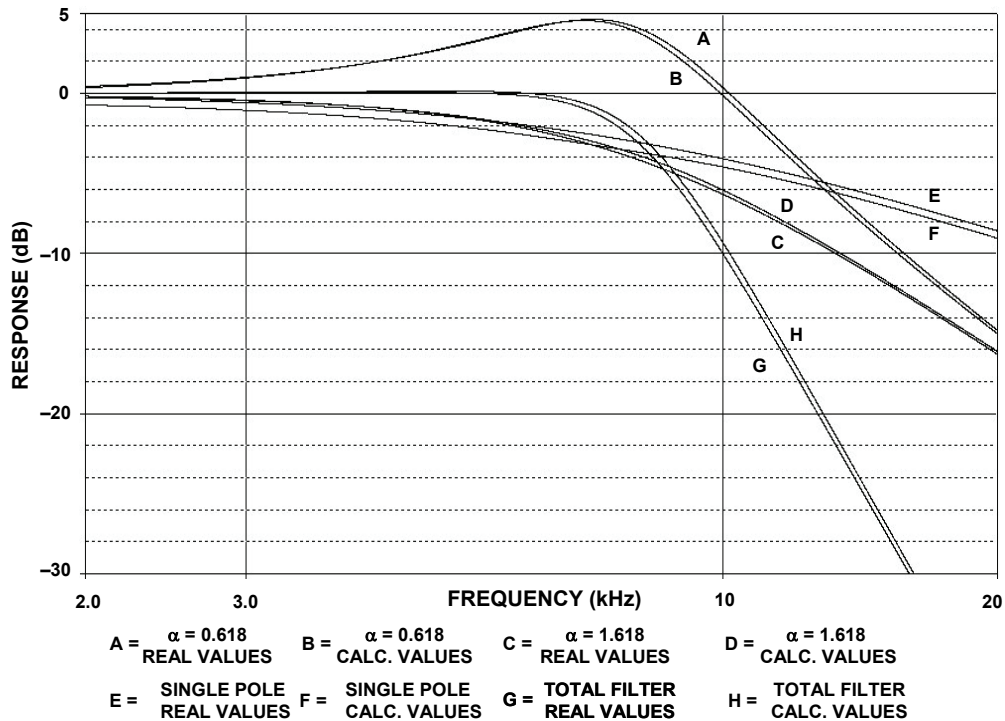

**Figure 8.100: Effect of Using Standard Value Resistors**

In active filter applications using op amps, the dc accuracy of the amplifier is often critical to optimal filter performance. The amplifier's offset voltage will be passed by the

low-pass filter and may be amplified to produce excessive output offset. For low frequency applications requiring large value resistors, bias currents flowing through these resistors will also generate an output offset voltage.

In addition, at higher frequencies, an op amp's dynamics must be carefully considered. Here, slew rate, bandwidth, and open-loop gain play a major role in op amp selection. The slew rate must be fast as well as symmetrical to minimize distortion.

## ▣ BASIC LINEAR DESIGN

### Transformations

In the next example the transformation process will be investigated.

As mentioned earlier, filter theory is based on a low pass prototype, which is then manipulated into the other forms. In these examples the prototype that will be used is a 1 kHz, 3 pole, 0.5 dB Chebyshev filter. A Chebyshev was chosen because it would show more clearly if the responses were not correct, a Butterworth would probably be too forgiving in this instance. A 3 pole filter was chosen so that a pole pair and a single-pole would be transformed.

The pole locations for the LP prototype were taken from Figure 8.30. They are:

STAGE	$\alpha$	$\beta$	$F_0$	$\alpha$
1	0.2683	0.8753	1.0688	0.5861
2	0.5366		0.6265	

The first stage is the pole pair and the second stage is the single-pole. Note the unfortunate convention of using  $\alpha$  for 2 entirely separate parameters. The  $\alpha$  and  $\beta$  on the left are the pole locations in the s-plane. These are the values that are used in the transformation algorithms. The  $\alpha$  on the right is  $1/Q$ , which is what the design equations for the physical filters want to see.

The Sallen-Key topology will be used to build the filter. The design equations in Figure 8.67 (pole pair) and Figure 8.66 (single pole) were then used to design the filter. The schematic is shown in Figure 8.101.

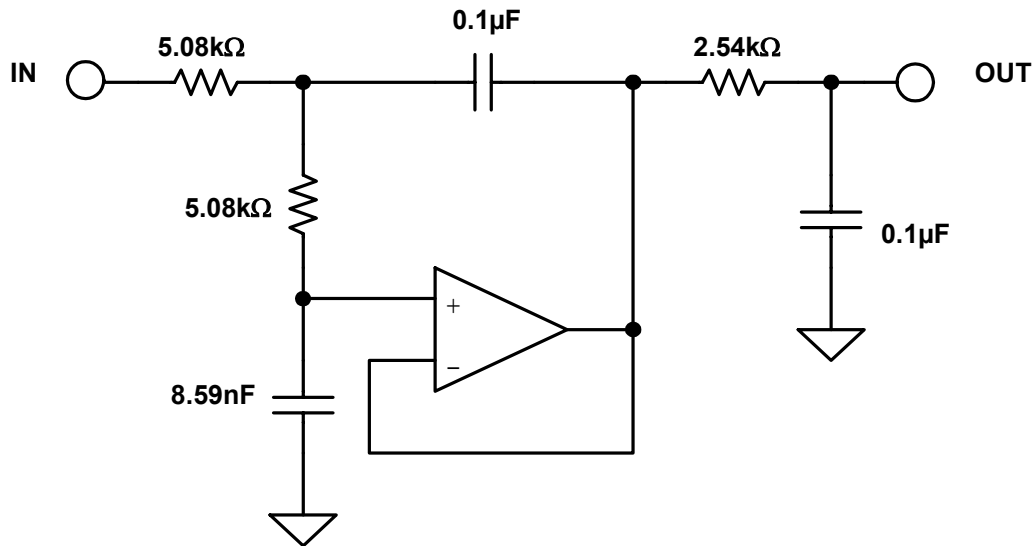

**Figure 8.101: Low-Pass Prototype**

Using the equation string described in Section 8, the filter is now transformed into a high-pass filter. The results of the transformation are:

STAGE	$\alpha$	$\beta$	$F_0$	$\alpha$
1	0.3201	1.0443	0.9356	0.5861
2	1.8636		1.596	

A word of caution is warranted here. Since the convention of describing a Chebyshev filter is to quote the end of the error band instead of the 3 dB frequency, the  $F_0$  must be divided (for high-pass) by the ratio of ripple band to 3 dB bandwidth (Table 1, Section 4).

The Sallen-Key topology will again be used to build the filter. The design equations in Figure 8.68 (pole pair) and Figure 8.66 (single pole) were then used to design the filter. The schematic is shown in Figure 8.102.

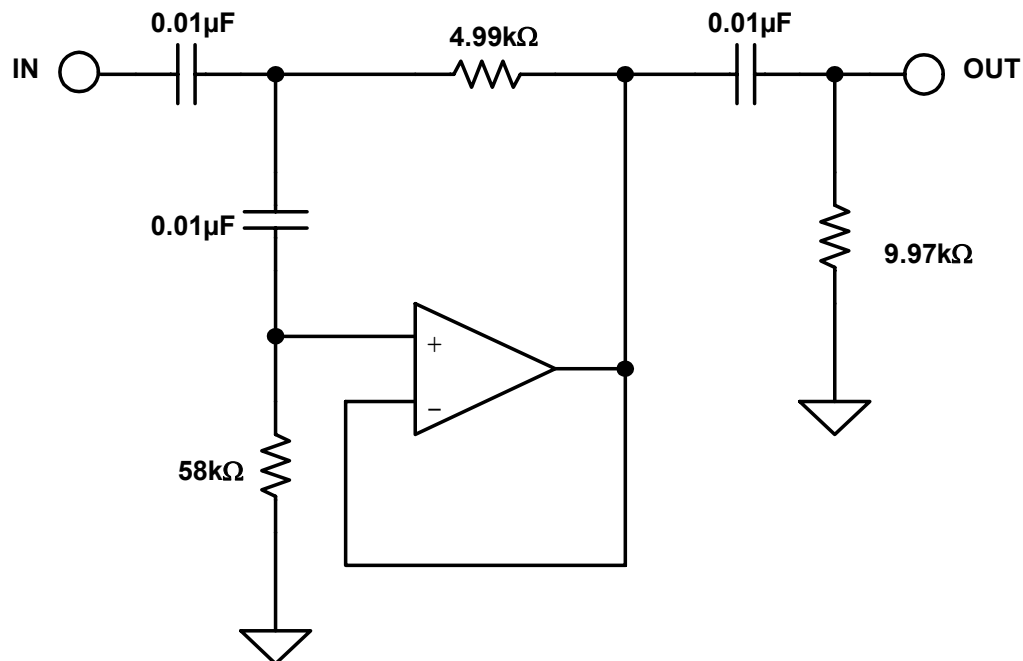

**Figure 8.102: High-Pass Transformation**

Figure 8.103 shows the response of the low-pass prototype and the high-pass transformation. Note that they are symmetric around the cutoff frequency of 1 kHz. Also note that the error band is at 1 kHz, not the  $-3$  dB point, which is characteristic of Chebyshev filters.

## ▣ BASIC LINEAR DESIGN

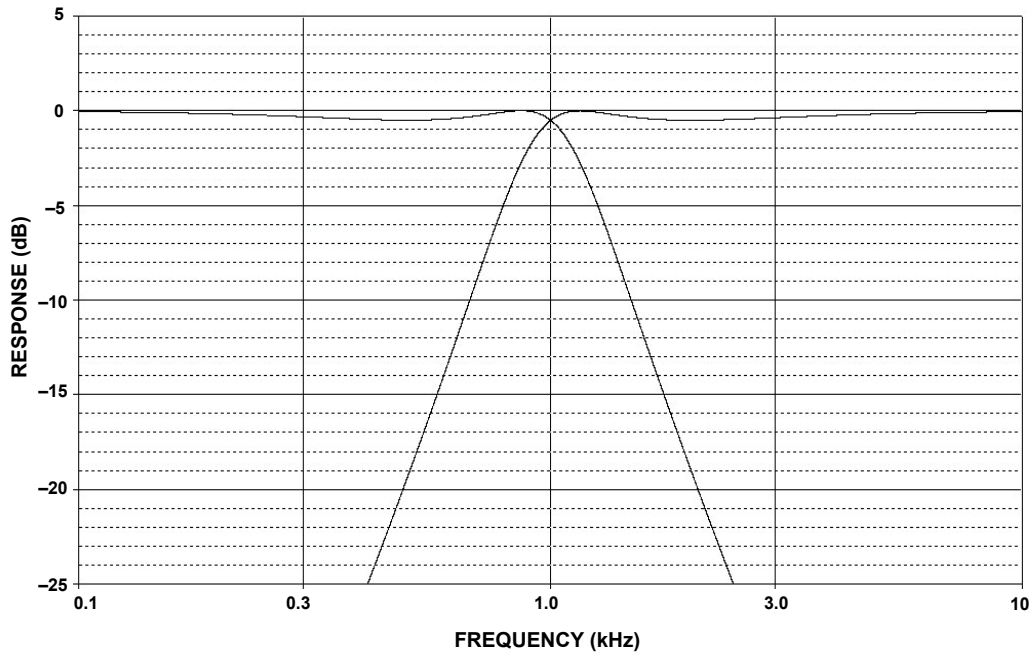

**Figure 8.103: Low-Pass and High-Pass Response**

The low-pass prototype is now converted to a band-pass filter. The equation string outlined in Section 8.5 is used for the transformation. Each pole of the prototype filter will transform into a pole pair. Therefore the 3 pole prototype, when transformed, will have 6 poles (3 pole pairs). In addition, there will be 6 zeros at the origin.

Part of the transformation process is to specify the 3 dB bandwidth of the resultant filter. In this case this bandwidth will be set to 500 Hz. The results of the transformation yield:

STAGE	$F_0$	Q	$A_0$
1	804.5	7.63	3.49
2	1243	7.63	3.49
3	1000	3.73	1

The reason for the gain requirement for the first 2 stages is that their center frequencies will be attenuated relative to the center frequency of the total filter. Since the resultant Q's are moderate (less than 20) the Multiple Feedback topology will be chosen. Figure 8.72 was then used to design the filter sections.

Figure 8.104 is the schematic of the filter and Figure 8.105 shows the filter response.

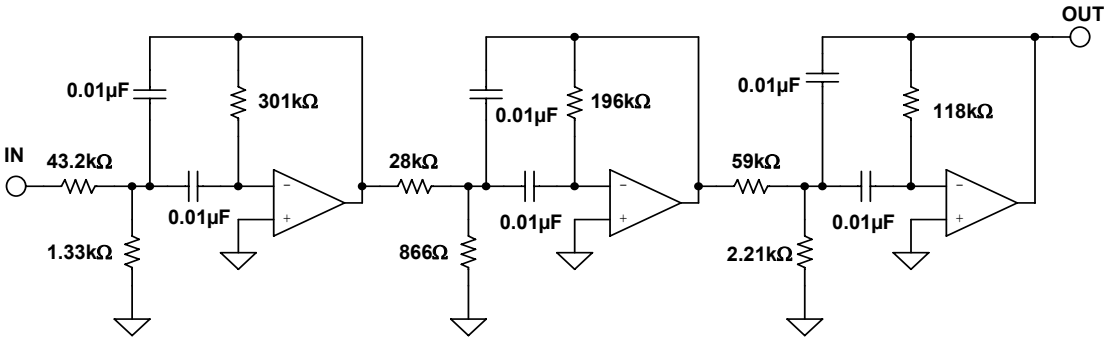

**Figure 8.104: Band-Pass Transformation**

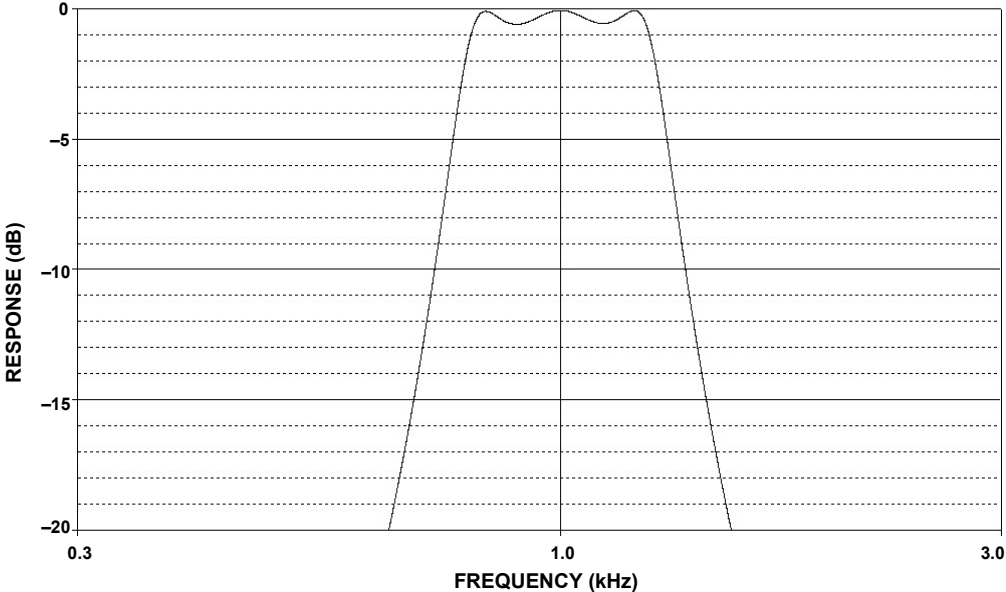

**Figure 8.105: Band-Pass Filter Response**

Note that again there is symmetry around the center frequency. Also the 800 Hz bandwidth is not 250 Hz either side of the center frequency (arithmetic symmetry). Instead the symmetry is geometric, which means that for any 2 frequencies ( $F_1$  &  $F_2$ ) of equal amplitude are related by:

$$F_0 = \sqrt{F_1 \cdot F_2} \tag{Eq. 8-96}$$

Lastly the prototype will be transformed into a band-reject filter. For this the equation string in Section 8.5 is used. Again, each pole of the prototype filter will transform into a pole pair. Therefore, the 3 pole prototype, when transformed, will have 6 poles (3 pole pairs).

## ■ BASIC LINEAR DESIGN

As in the band-pass case, part of the transformation process is to specify the 3 dB bandwidth of the resultant filter. Again in this case this bandwidth will be set to 500 Hz. The results of the transformation yield:

STAGE	$F_0$	Q	$F_{0Z}$
1	763.7	6.54	1000
2	1309	6.54	1000
3	1000	1.07	1000

Note that there are three cases of notch filters required. There is a standard notch ( $F_0 = F_Z$ , section 3), a low-pass notch ( $F_0 < F_Z$ , section 1) and a high-pass notch ( $F_0 > F_Z$ , section 2). Since there is a requirement for all 3 types of notches, the Bainter Notch is used to build the filter. The filter is designed using Figure 8.77. The gain factors  $K_1$  and  $K_2$  are arbitrarily set to 1. Figure 8.106 is the schematic of the filter.

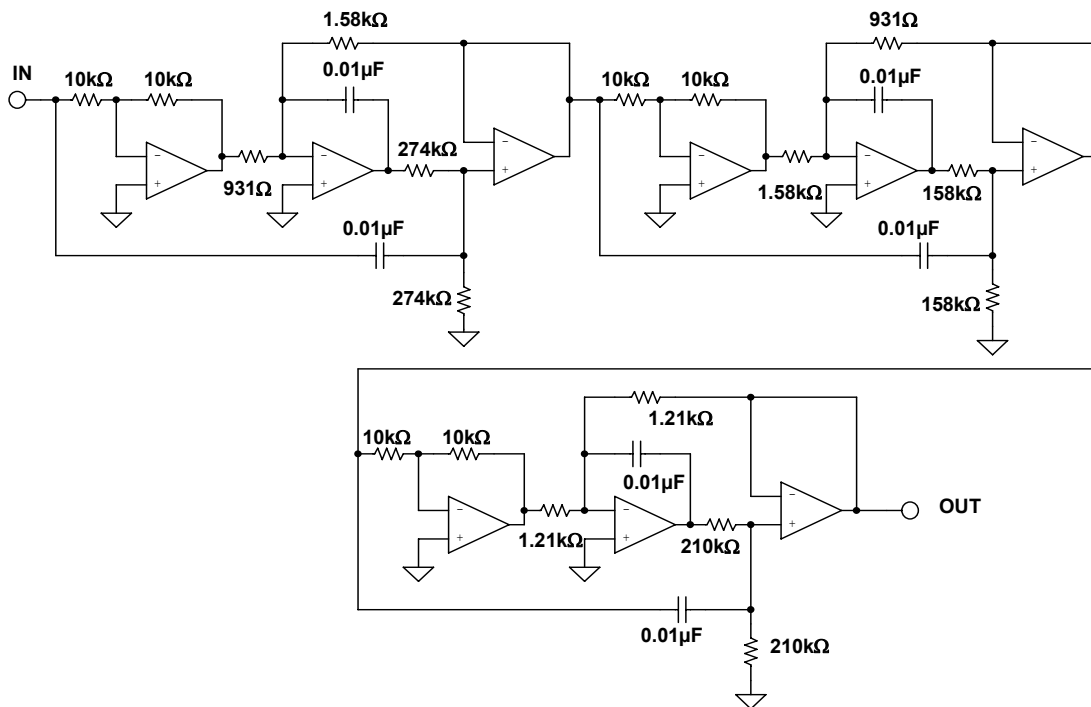

**Figure 8.106: Band-reject Transformation**



The response of the filter is shown in Figure 8.107 and in detail in Figure 8.108. Again, note the symmetry around the center frequency. Again the frequencies have geometric symmetry.

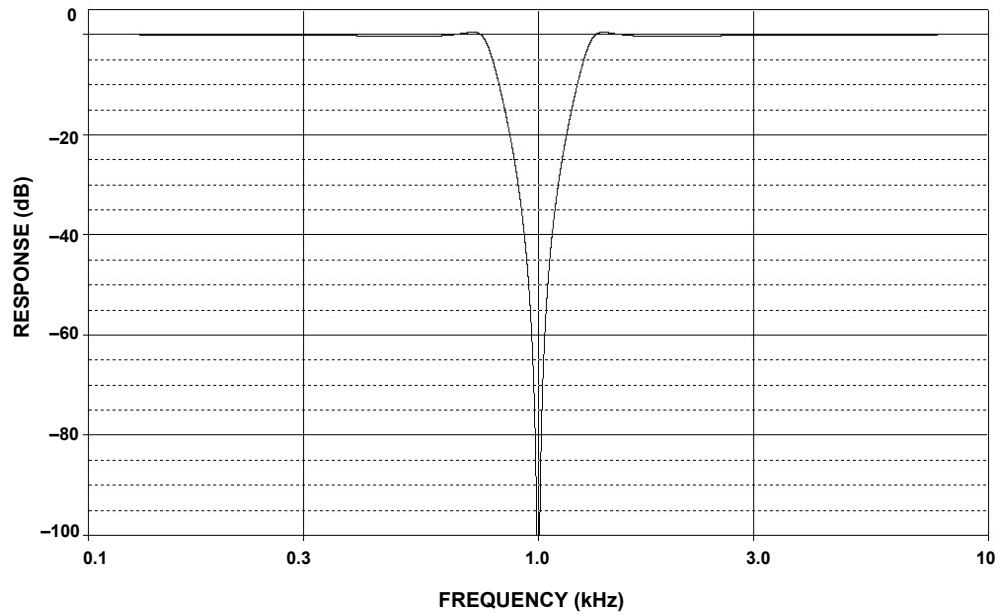

**Figure 8.107: Band-reject Response**

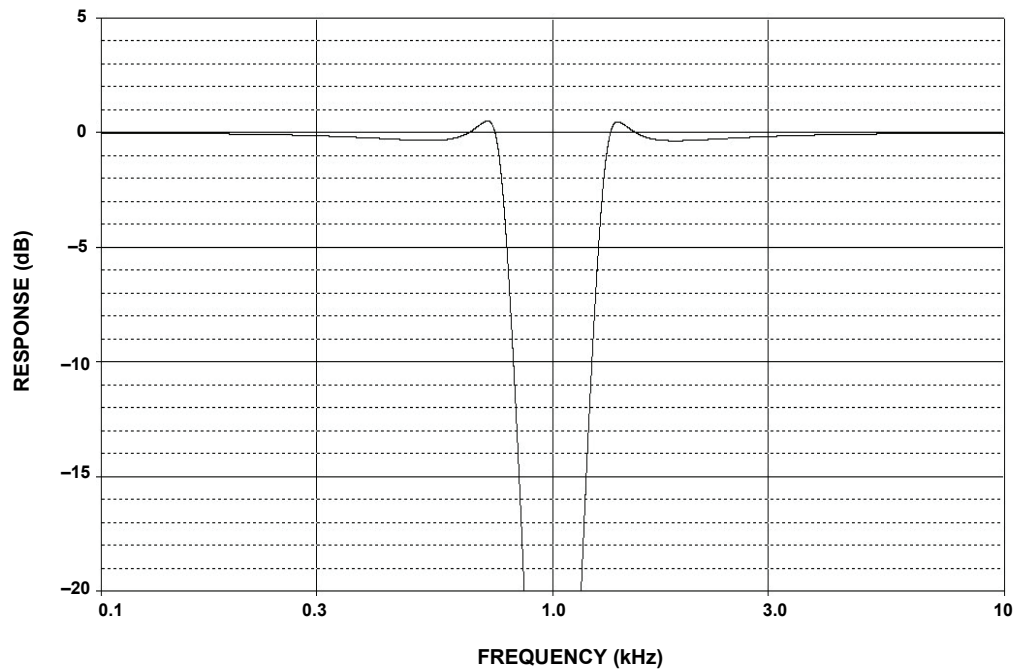

**Figure 8.108: Band-reject Response (detail)**

## ▣ BASIC LINEAR DESIGN

### CD Reconstruction Filter

This design was done for a magazine article describing a high quality outboard D/A converter for use with digital audio sources (see Reference 26).

A reconstruction filter is required on the output of a D/A converter because, despite the name, the output of a D/A converter is not really an analog voltage but instead a series of steps. The converter will put out a discrete voltage, which it will then hold until the next sample is asserted. The filter's job is to remove the high frequency components, smoothing out the waveform. This is why the filter is sometimes referred to as a smoothing filter. This also serves to eliminate the aliases of the conversion process. The "standard" in the audio industry is to use a 3<sup>rd</sup>-order Bessel function as the reconstruction filter. The reason to use a Bessel filter is that it has the best phase response. This helps to preserve the phase relationship of the individual tones in the music. The price for this phase "goodness" is that the amplitude discrimination is not as good as some other filter types. If we assume that we are using 8× oversampling of the 48 kSPS data stream in the D/A converter then the aliases will appear at 364 kHz ( $8 \times 48 \text{ k} - 20 \text{ k}$ ). The digital filter that is used in the interpolation process will eliminate the frequencies between 20 kHz and 364 kHz. If we assume that the band-edge is 30 kHz, then we have a frequency ratio of approximately 12 ( $364 \div 30$ ). We use 30 kHz as the band-edge, rather than 20 kHz to minimize the rolloff due to the filter in the pass-band. In fact, the complete design for this filter includes a shelving filter to compensate for the pass-band rolloff. Extrapolating from Figure 8.20, a 3<sup>rd</sup>-order Bessel will only provide on the order of 55 dB attenuation at  $12 \times F_0$ . This is only about 9 bit accuracy.

By designing the filter as 7<sup>th</sup> order, and by designing it as a linear phase with equiripple error of  $0.05^\circ$ , we can increase the stopband attenuation to about 120 dB at  $12 \times F_0$ . This is close to the 20 bit system that we are hoping for.

The filter will be designed as a FDNR type. This is an arbitrary decision. Reasons to choose this topology are its low sensitivities to component tolerances and the fact that the op amps are in the shunt arms rather than in the direct signal path.

The first step is to find the passive prototype. To do this, use the charts in Williams' book. We then get the circuit shown in Figure 8.109A. Next perform a translation in the s-plane. This gives the circuit shown in Figure 8.109B. This filter is scaled for a frequency of 1 Hz. and an impedance level of  $1 \Omega$ . The D structure of the converted filter is replaced by a GIC structure that can be physically realized. The filter is then denormalize by frequency (30 kHz) and impedance (arbitrarily chosen to be  $1 \text{ k}\Omega$ ). This gives a frequency-scaling factor (FS) of  $1.884 \times 10^5$  ( $= 2\pi (3 \times 10^4)$ ). Next arbitrarily choose a value of 1 nF for the capacitor. This gives an impedance-scaling factor (Z) of 5305 ( $= (C_{\text{OLD}}/C_{\text{NEW}}) / \text{FSF}$ ).

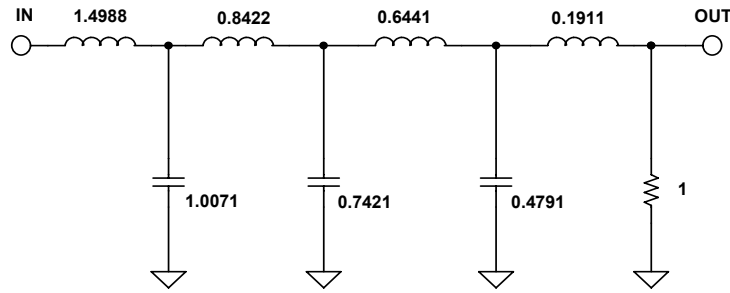

Figure 8.109A: CD Reconstruction Filter—Passive Prototype

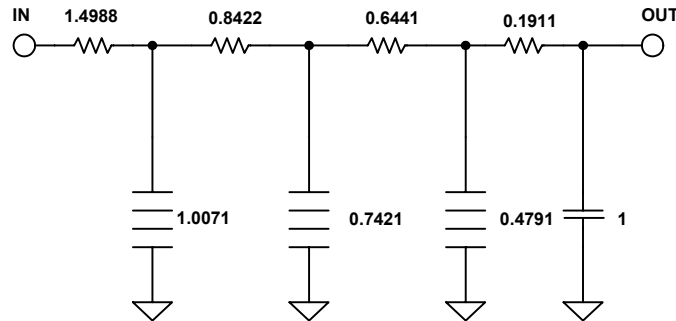

Figure 8.109B: CD Reconstruction Filter—Transformation in  $s$ -Plane

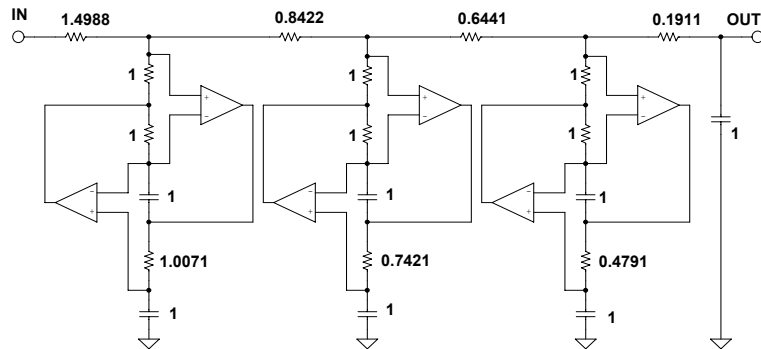

Figure 8.109C: CD Reconstruction Filter—Normalized FDNR

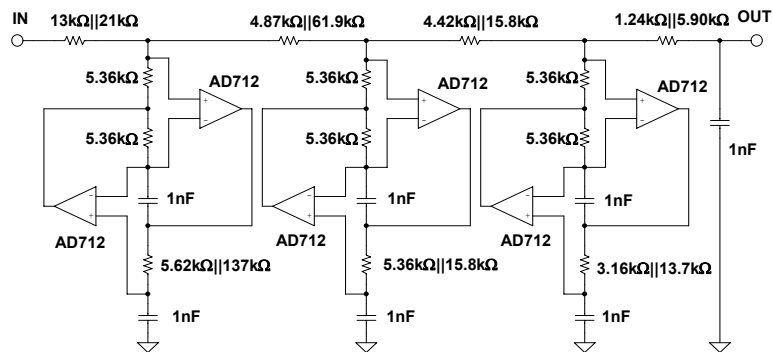

Figure 8.109D: CD Reconstruction Filter—Final Filter

## ▣ BASIC LINEAR DESIGN

Then multiply the resistor values by  $Z$ . This results in the resistors that had the normalized value of  $1\ \Omega$  will now have a value of  $5.305\ \text{k}\Omega$ . For the sake of simplicity adopt the standard value of  $5.36\ \text{k}\Omega$ . Working backwards, this will cause the cutoff frequency to change to  $29.693\ \text{kHz}$ . This slight shift of the cutoff frequency will be acceptable.

The frequency scaling factor is then recalculated with the new center frequency and this value is used to denormalize the rest of the resistors. The design flow is illustrated in Figure 8.109. The final schematic is shown in Figure 8.109D.

The performance of the filter is shown in Figure 8.110(A-D).

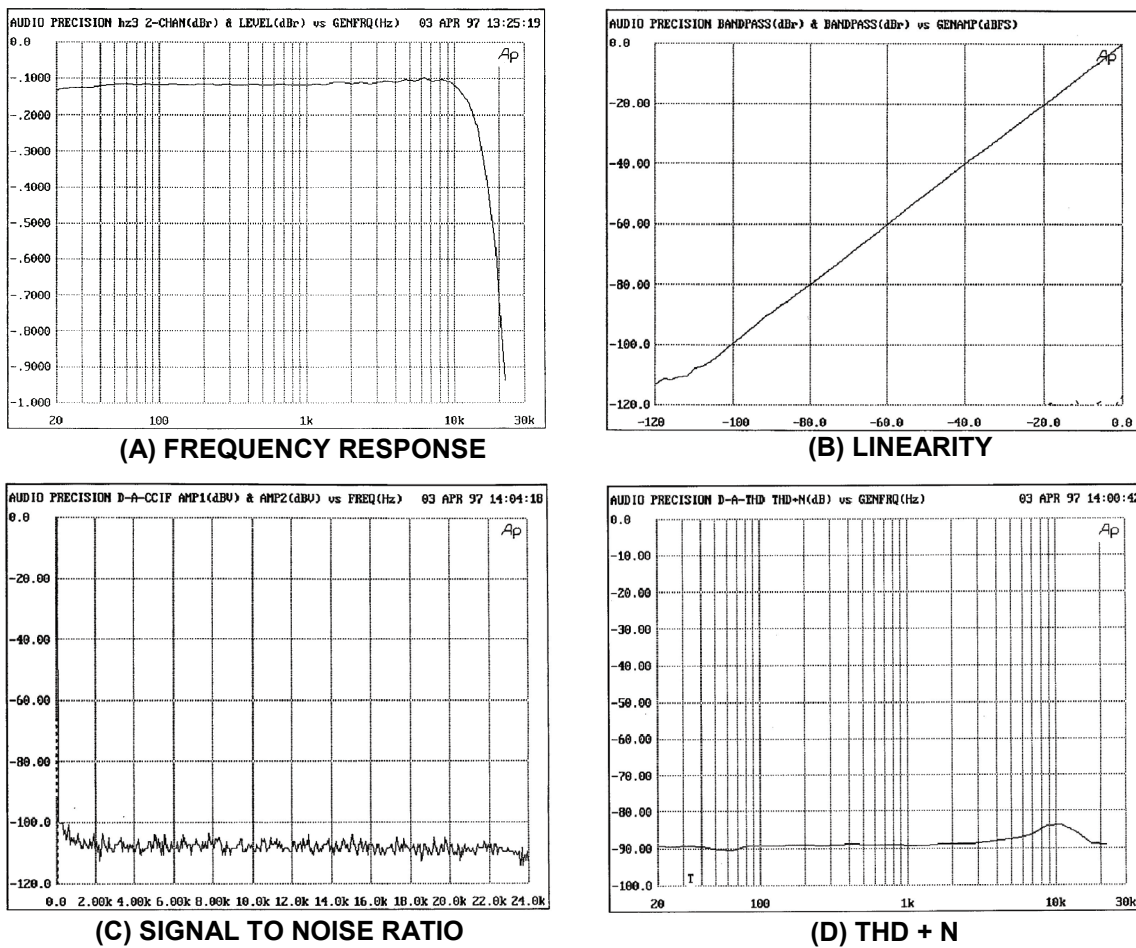

*Figure 8.110: CD Filter Performance*



## ▣ BASIC LINEAR DESIGN

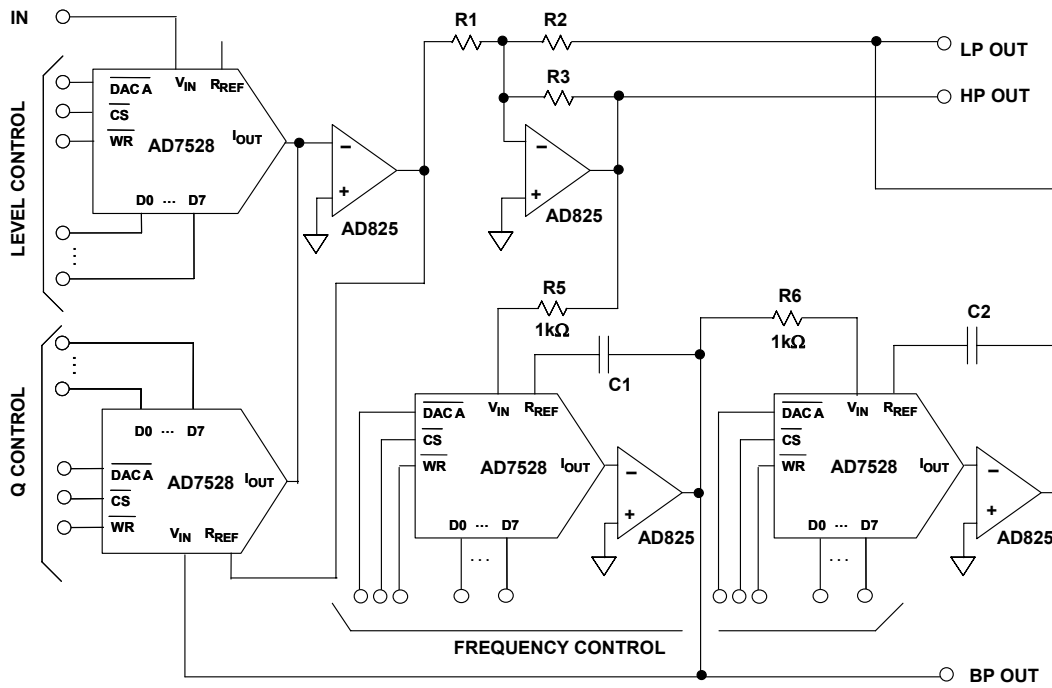

**Figure 8.112: Digitally Controlled State Variable Filter**

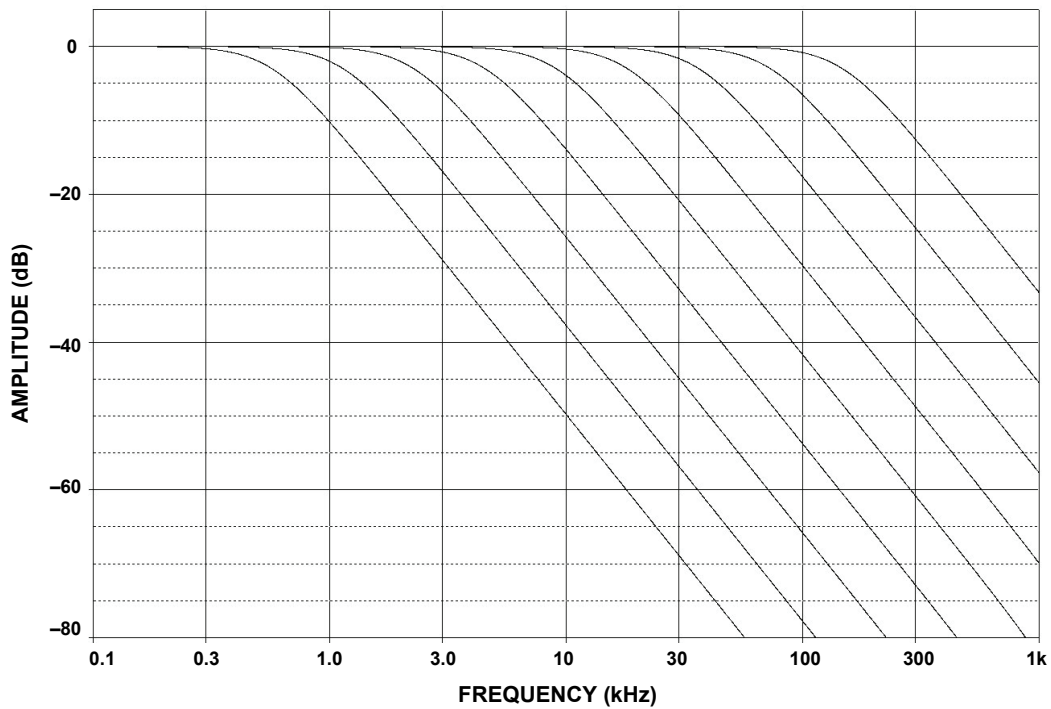

**Figure 8.113: Frequency Response vs. DAC Control Word**

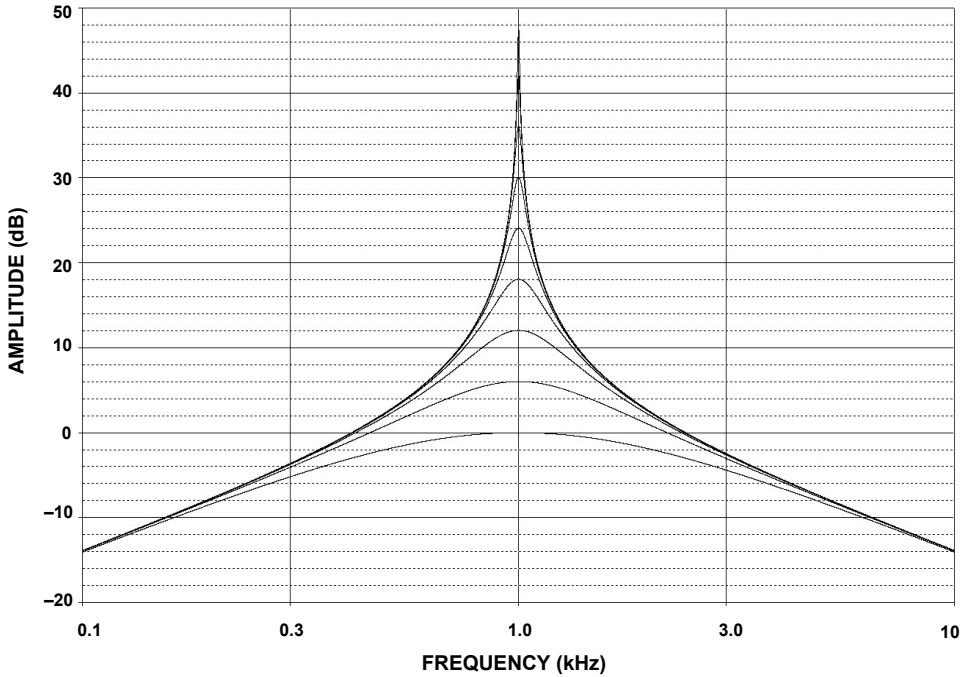

*Figure 8.114: Q Variation vs. DAC Control Word*

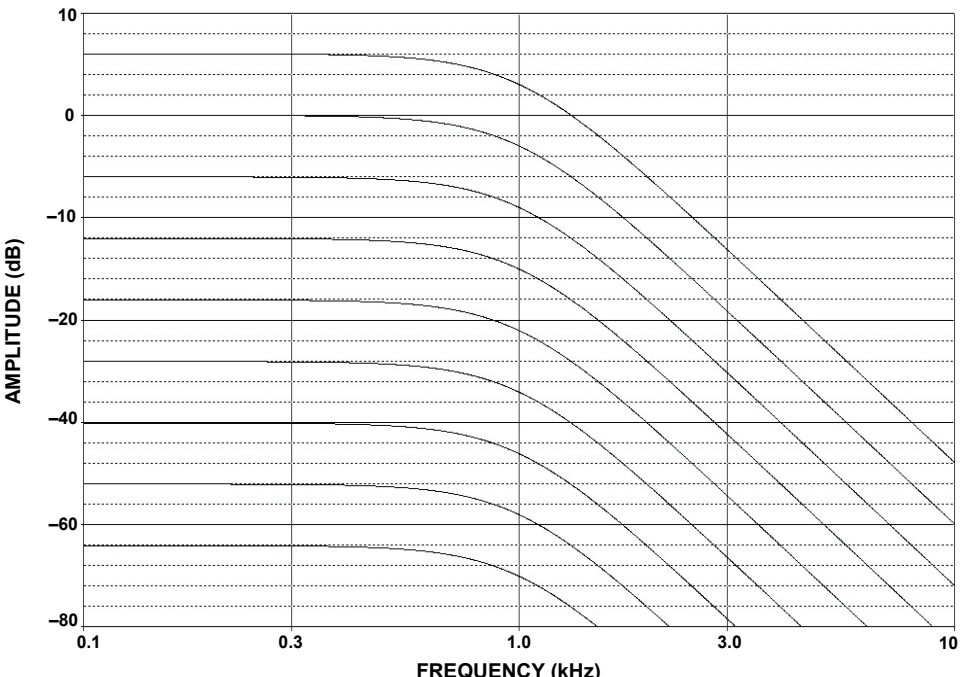

*Figure 8.115: Gain Variation vs. DAC Control Word*

## ■ BASIC LINEAR DESIGN

One limitation of this design is that the frequency is dependent on the ladder resistance of the DAC. This particular parameter is not controlled. DACs are trimmed so that the ratios of the resistors, not their absolute values, are controlled. In the case of the AD7528, the typical value is 11 k $\Omega$ . It is specified as 8 k $\Omega$  min. and 15 k $\Omega$  max. A simple modification of the circuit can eliminate this issue. The cost is 2 more op amps (Figure 8.116). In this case, the effective resistor value is set by the fixed resistors rather than the DAC's resistance. Since there are 2 integrators the extra inversions caused by the added op amps cancel.

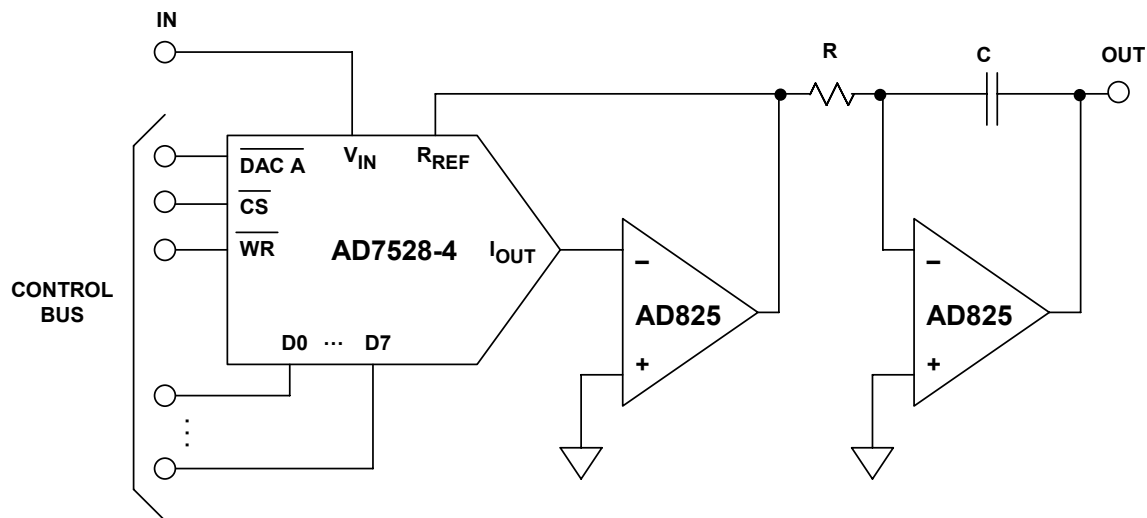

*Figure 8.116: Improved Digitally Variable Integrator*

As a side note, the multiplying DACs could be replaced by analog multipliers. In this case the control would obviously be an analog rather than a digital signal. We also could just as easily have used a digital pot in place of the MDACs. The difference is that instead of increasing the effective resistance, the value of the pot would be the maximum.



### 60 Hz Notch Filter

A very common problem in instrumentation is that of interference of the telemetry that is to be measured. One of the primary sources of this interference is the power line. This is particularly true of high impedance circuits. Another path for this noise is ground loops. One possible solution is to use a notch filter to remove the 60 Hz component. Since this is a single frequency interference, the Twin-T circuit will be used.

Since the maximum attenuation is desired and the minimum notch width is desired, the maximum Q of the circuit is desired. This means the maximum amount of positive feedback is used (R5 open and R4 shorted). Due to the high impedance of the network, a FET input op amp is used.

The filter is designed using Figure 8.78. The schematic is shown in Figure 8.117 and the response in Figure 8.118.

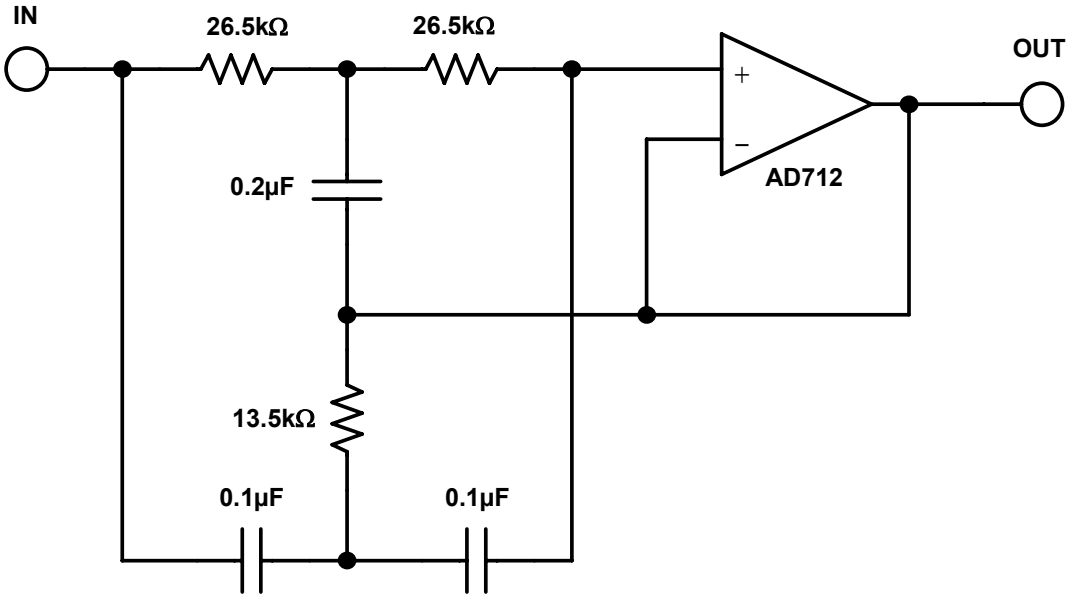
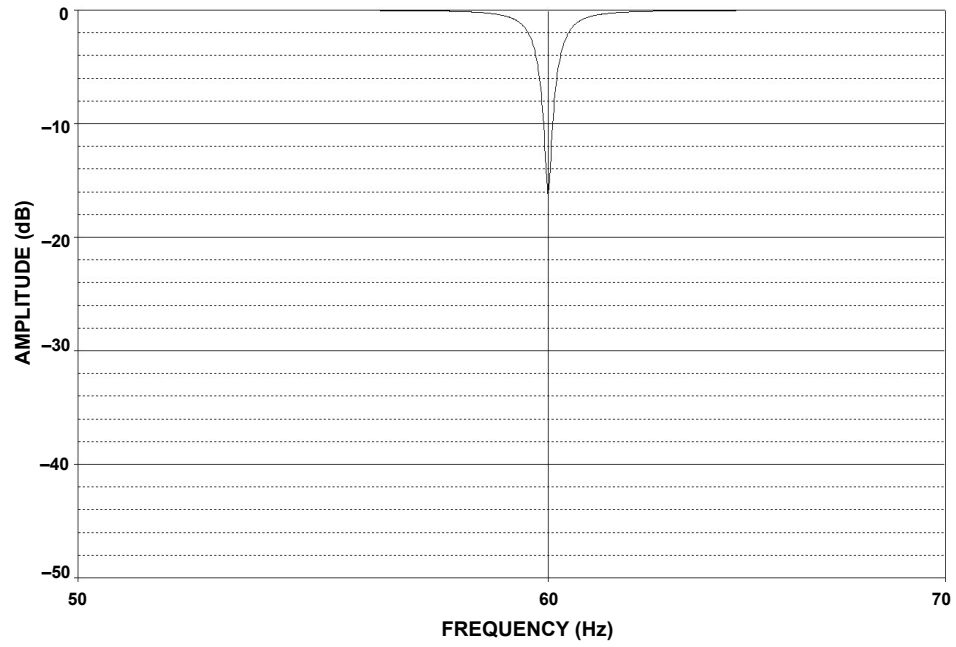

Figure 8.117: 60 Hz Twin-T Notch Filter

## ▣ BASIC LINEAR DESIGN



*Figure 8.118: 60 Hz Notch Filter Response*

## REFERENCES:

1. A. I. Zverev, **Handbook of Filter Synthesis**, John Wiley, 1967.
2. A. B. Williams, **Electronic Filter Design Handbook**, McGraw-Hill, 1981, ISBN: 0-07-070430-9.
3. M. E. Van Valkenburg, **Analog Filter Design**, Holt, Rinehart & Winston, 1982
4. M. E. Van Valkenburg, **Introduction to Modern Network Synthesis**, John Wiley and Sons, 1960.
5. A. I. Zverev and H. J. Blinichikoff, **Filtering in the Time and Frequency Domain**, John Wiley and Sons, 1976.
6. S. Franco, **Design with Operational Amplifiers and Analog Integrated Circuits**, McGraw-Hill 1988, ISBN: 0-07-021799-8.
7. W. Cauer, **Synthesis of Linear Communications Networks**, McGraw-Hill, New York, 1958.
8. Aram Budak, **Passive and Active Network Analysis and Synthesis**, Houghton Mifflin Company, Boston, 1974.
9. L. P. Huelsman and P. E. Allen, **Introduction to the Theory and Design of Active Filters**, McGraw Hill, 1980, ISBN: 0-07-030854-3.
10. R. W. Daniels, **Approximation Methods for Electronic Filter Design**, McGraw-Hill, New York, 1974.
11. J. Tow, "Active RC Filters – a State-space Realization", **Proc. IEEE**, 1968, vol. 56, pp. 1137-1139.
12. L.C. Thomas, "The Biquad: Part I – Some Practical Design Considerations", **IEEE Trans. Circuits and Systems**, Vol. CAS-18, 1971, pp. 350-357.
13. L.C. Thomas, "The Biquad: Part I – A Multipurpose Active Filtering System," **IEEE Trans. Circuits and Systems**, Vol. CAS-18, 1971, pp. 358-361.
14. R. P. Sallen and E. L. Key, "A Practical Method of Designing RC Active Filters," **IRE Trans. Circuit Theory**, Vol. CT-2, 1955, pp. 74-85.
15. P. R. Geffe, "How to Build High-Quality Filters out of Low-Quality Parts," **Electronics**, Nov. 1976, pp. 111-113.
16. P. R. Geffe, "Designers Guide to Active Bandpass Filters," **EDN**, Apr. 5 1974, pp. 46-52.
17. T. Delyiannis, "High-Q Factor Circuit with Reduced Sensitivity," **Electronics Letters**, 4, Dec. 1968, p. 577.
18. J. J. Friend, "A Single Operational-Amplifier Biquadratic Filter Section," **1970 IEEE ISCT Digest Technical Papers**, 1970 p. 189.
19. L. Storch, "Synthesis of Constant-Time-Delay Ladder Networks Using Bessel Polynomials," **Proceedings of IRE**, Vol. 42, 1954, pp. 1666-1675.
20. K. W. Henderson and W. H. Kautz, "Transient Response of Conventional Filters," **IRE Trans. Circuit Theory**, Vol. CT-5, 1958, pp. 333-347.

## ▣ BASIC LINEAR DESIGN

21. J. R. Bainter, "Active Filter Has Stable Notch and Response Can be Regulated," **Electronics**, Oct. 2 1975, pp.115-117.
22. S. A. Boctor, "Single Amplifier Functionally Tunable Low-Pass Notch Filter," **IEEE Trans. Circuits and Systems**, Vol. CAS-22, 1975, pp. 875-881.
23. S. A. Boctor, "A Novel second-order canonical RC-Active Realization of High-Pass-Notch Filter," **Proc. 1974 IEEE Int. Symp. Circuits and Systems**, pp. 640-644.
24. L. T. Burton, "Network Transfer Function Using the Concept of Frequency Dependant Negative Resistance," **IEEE Trans. Circuit Theory**, Vol. CT-16, 1969, pp. 406-408.
25. L. T. Burton and D. Trefleaven, "Active Filter Design Using General Impedance Converters," **EDN**, Feb. 1973, pp.68-75.
26. H. Zumbahlen, "A New Outboard DAC, Part 2," **Audio Electronics**, Jan. 1997, pp. 26-32, 42.
27. M. Williamsen, "Notch-Filter Design," **Audio Electronics**, Jan. 2000, pp. 10-17.
28. W. Jung, "Bootstrapped IC Substrate Lowers Distortion in JFET Op Amps," Analog Devices AN232.
29. H. Zumbahlen, "Passive and Active Filtering," Analog Devices AN281.
30. P. Toomey & W. Hunt, "AD7528 Dual 8-Bit CMOS DAC," Analog Devices AN318.
31. W. Slattery, "8th Order Programmable Lowpass Analog Filter Using 12-Bit DACs," Analog Devices AN209.
32. **CMOS DAC Application Guide**, Analog Devices.