

Lecture 11

Single Stage FET Amplifiers: Common Source (CS) Amplifier

The Building Blocks of Analog Circuits - I

In this lecture you will learn:

- General amplifier concepts (in terms of the two-port models)
- Common source amplifier (CS)
- Small signal models of amplifiers

Reminder: Thevenin and Norton Equivalent Circuits

Consider an arbitrary linear circuit:

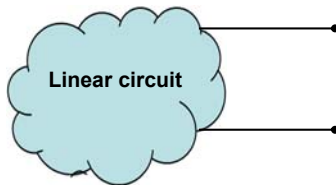

It can be represented by any two of the following equivalent circuits:

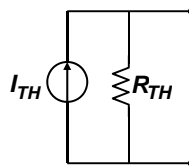
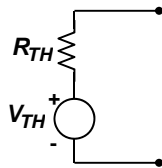

$$V_{TH} = I_{TH}R_{TH}$$

Types of Linear Amplifiers

There are four basic types of amplifiers that we will study in this course:

- 1) Voltage to Voltage Amplifiers (or just **Voltage Amplifiers**)



- 2) Voltage to Current Amplifiers (or **Transconductance Amplifiers**)

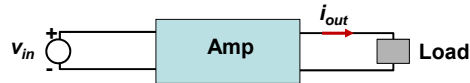

- 3) Current to Current Amplifiers (or just **Current Amplifiers**)

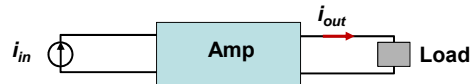

- 4) Current to Voltage Amplifiers (or **Transimpedance Amplifiers**)



Two-Port Amplifier Models: A Voltage Amplifier

A Voltage Amplifier:

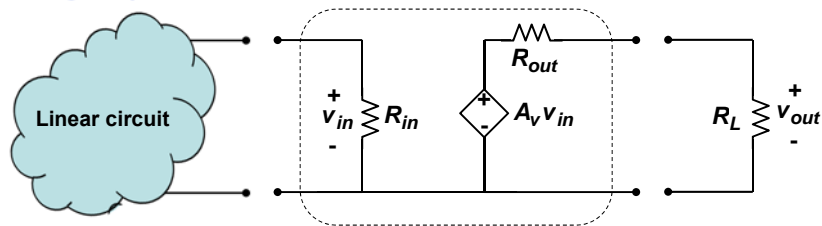

Can be represented as

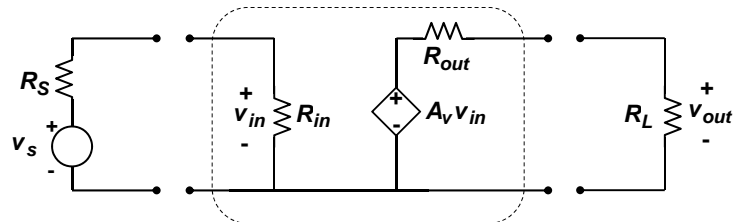

Two-Port Amplifier Models: A Voltage Amplifier

A Voltage Amplifier:

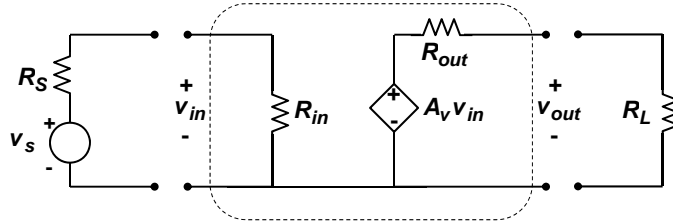

$$\frac{v_{out}}{v_s} = A_v \left(\underbrace{\frac{R_{in}}{R_{in} + R_S}}_{\text{Input voltage divider}} \right) \left(\underbrace{\frac{R_L}{R_{out} + R_L}}_{\text{Output voltage divider}} \right)$$

Requirements:

Large input resistance R_{in}
Small output resistance R_{out}

Open circuit output voltage gain (i.e. when $R_L = \infty$):

$$\frac{v_{out}}{v_{in}} = A_v = \text{Voltage gain}$$

Two-Port Amplifier Models: A Current Amplifier

A Current Amplifier:

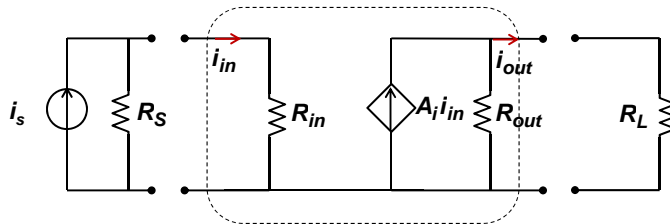

$$\frac{i_{out}}{i_s} = A_i \left(\underbrace{\frac{R_S}{R_S + R_{in}}}_{\text{Input current divider}} \right) \left(\underbrace{\frac{R_{out}}{R_{out} + R_L}}_{\text{Output current divider}} \right)$$

Requirements:

Small input resistance R_{in}
Large output resistance R_{out}

Short circuit output current gain (i.e. when $R_L = 0$):

$$\frac{i_{out}}{i_{in}} = A_i = \text{Current gain}$$

Two-Port Amplifier Models: A Transconductance Amplifier

A Transconductance Amplifier (or a Voltage-to-Current Amplifier):

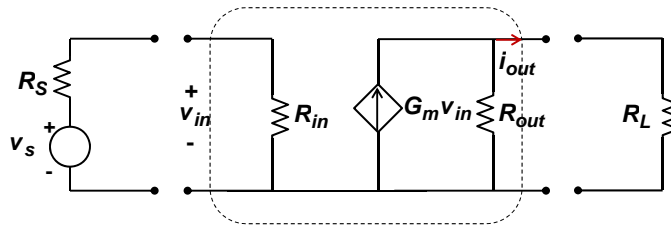

$$\frac{i_{out}}{v_s} = G_m \left(\frac{R_{in}}{R_S + R_{in}} \right) \left(\frac{R_{out}}{R_{out} + R_L} \right)$$

Input voltage divider
Output current divider

Requirements:

Large input resistance R_{in}
 Large output resistance R_{out}

Short circuit output current and transconductance gain (i.e. when $R_L = 0$):

$$\frac{i_{out}}{v_{in}} = G_m = \text{Transconductance gain}$$

Two-Port Amplifier Models: A Transimpedance Amplifier

A Transimpedance (or a Transresistance) Amplifier (or a Current-to-Voltage Amplifier):

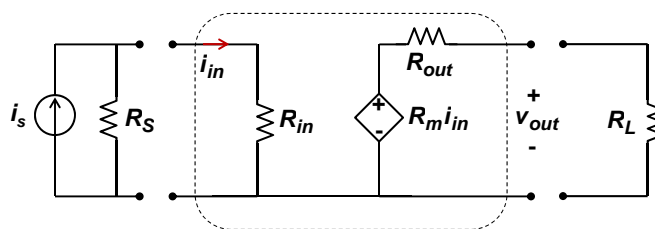

$$\frac{v_{out}}{i_s} = R_m \left(\frac{R_S}{R_S + R_{in}} \right) \left(\frac{R_L}{R_{out} + R_L} \right)$$

Input current divider
Output voltage divider

Requirements:

Small input resistance R_{in}
 Small output resistance R_{out}

Open circuit output voltage and transimpedance gain (i.e. when $R_L = \infty$):

$$\frac{v_{out}}{i_{in}} = R_m = \text{Transimpedance gain}$$

Two-Port Amplifier Models: General Concepts

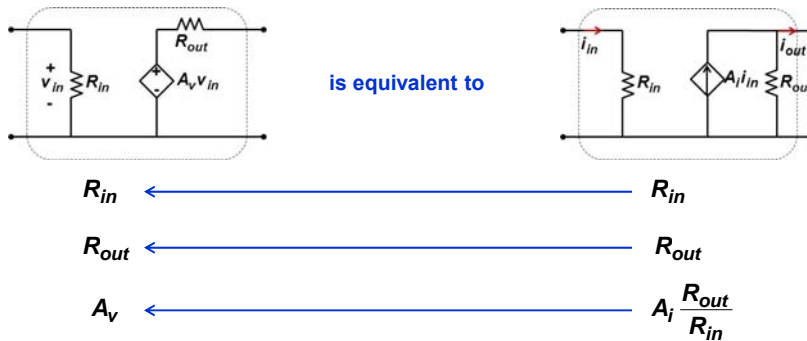

The two-port models are equivalent (inter-convertible)

The designation of an amplifier as a voltage, current, transconductance, or transimpedance amplifier depends on the values of the input and output resistances

Need to find the **input resistance**, **output resistance**, **open circuit voltage gain**, and **short circuit current gain** to characterize an amplifier

Unilateral Networks and Two-Port Amplifier Models

For many circuits and amplifiers, the kind of two-port models described here are not strictly valid

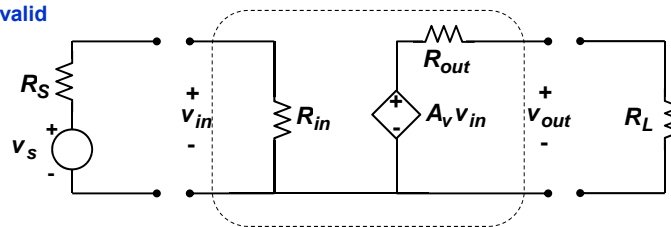

Reasons:

The input resistance R_{in} can depend on the load resistance R_L

The output resistance R_{out} can depend on the source resistance R_s

Circuits in which the above does not happen, and for which the two-port models described here are strictly valid, are **unilateral**

In many cases, even for non-unilateral networks, two-port models described here tend to be good approximations for **hand-calculations**

The Common Source Amplifier

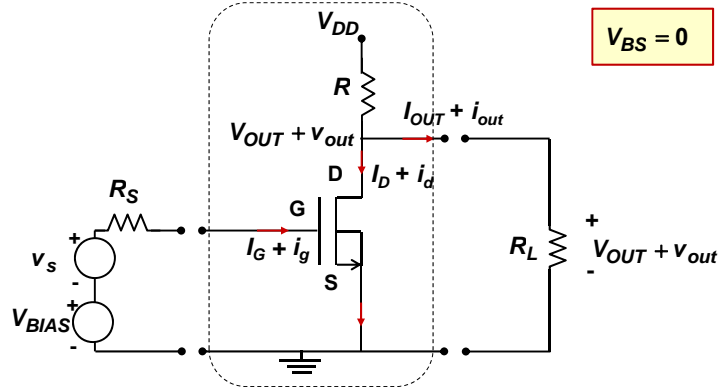

The source terminal is "common" between the input and the output

The Common Source Amplifier

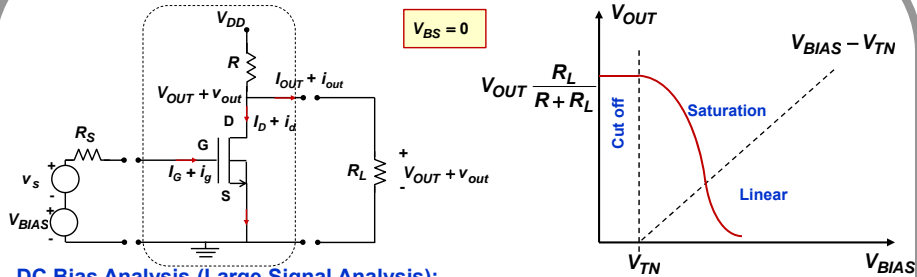

DC Bias Analysis (Large Signal Analysis):

Make sure the output load resistance R_L is included in the DC bias analysis

Start by assuming the FET is in saturation (and then later verify):

$$V_{DD} - (I_{OUT} + I_D)R = V_{OUT}$$

$$\Rightarrow V_{DD} - \left(\frac{V_{OUT}}{R_L} + I_D \right) R = V_{OUT}$$

$$\Rightarrow V_{OUT} = (V_{DD} - I_D R) \frac{R_L}{R + R_L}$$

$$I_D = \frac{k_n}{2} (V_{BIAS} - V_{TN})^2 (1 + \lambda_n V_{OUT})$$

$$I_D \approx \frac{k_n}{2} (V_{BIAS} - V_{TN})^2$$

The Common Source Amplifier: Small Signal Model

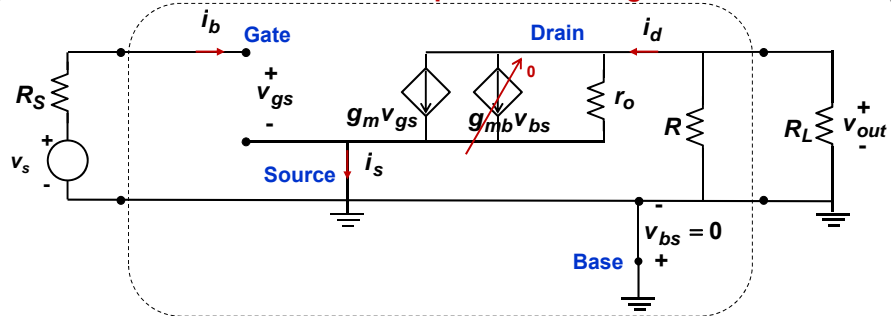

Compare with the standard voltage amplifier model:

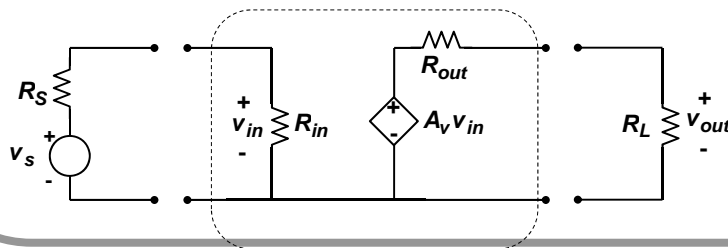

The Common Source Amplifier: Small Signal Model

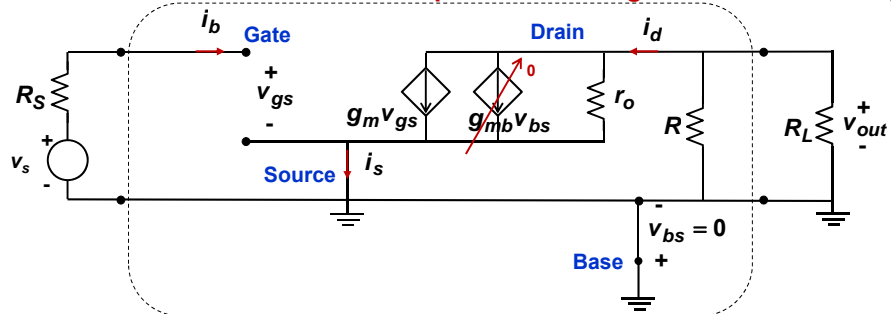

Compare with the standard transconductance amplifier model:

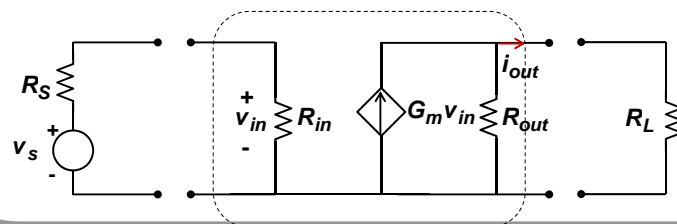

The Common Source Amplifier: Open Circuit Voltage Gain

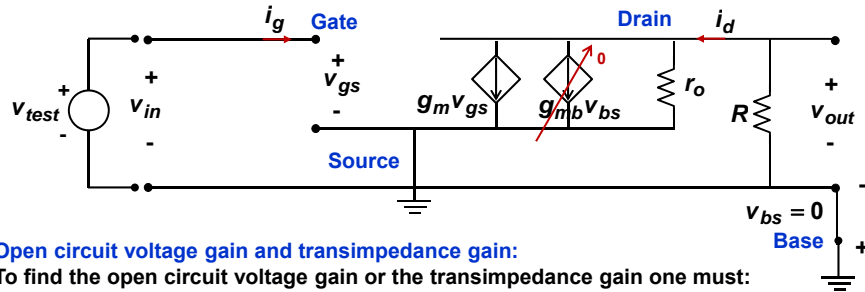

Open circuit voltage gain and transimpedance gain:

To find the open circuit voltage gain or the transimpedance gain one must:

- Remove the load resistance R_L at the output that the circuit will drive
- Then apply a test voltage source at the input
- Then find the resulting open circuit output voltage
- Take the ratio of the output voltage and the input voltage to find the **open circuit voltage gain**:

$$A_v = \frac{v_{out}}{v_{in}} = -\frac{i_d R}{v_{in}} = -g_m (r_o \parallel R)$$

- Or take the ratio of the output voltage and the input current to find the **transimpedance gain**:

$$R_m = \frac{v_{out}}{i_{in}} = -\infty$$

This result is somewhat artificial since at non-zero frequencies there will be a finite input current due to capacitances

The Common Source Amplifier: Short Circuit Current Gain

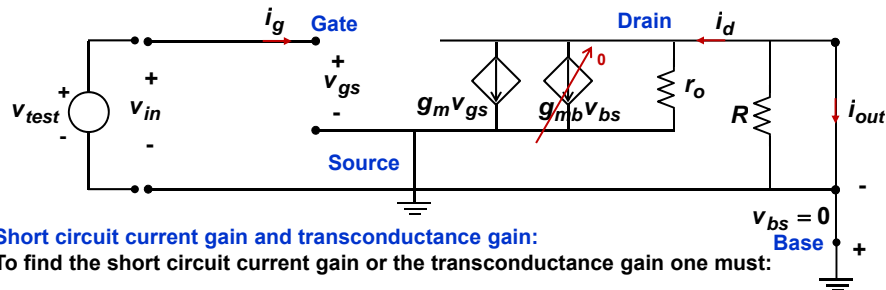

Short circuit current gain and transconductance gain:

To find the short circuit current gain or the transconductance gain one must:

- Short the load resistance R_L at the output that the circuit will drive
- Then apply a test voltage source at the input
- Then find the resulting current at the shorted output
- Take the ratio of the output and the input currents to find the **short circuit current gain**:

$$A_i = \frac{i_{out}}{i_g} = -\frac{g_m v_{gs}}{0} = \infty \longrightarrow \infty \text{ for the CS amplifier (at DC)}$$

This result is somewhat artificial since at non-zero frequencies there will be a finite input current due to capacitances

- Or take the ratio of the output current and the input voltage to find the **transconductance gain**:

$$G_m = \frac{i_{out}}{v_{in}} = -\frac{g_m v_{gs}}{v_{in}} = -g_m$$

The Common Source Amplifier: Input Resistance

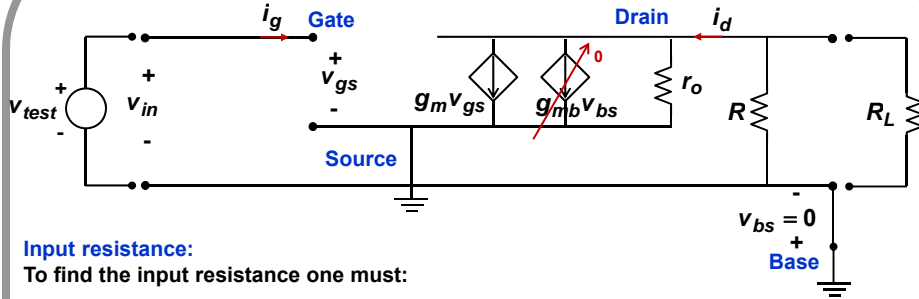

Input resistance:

To find the input resistance one must:

- i) Make sure the load resistance R_L that the circuit will drive is in place at the output
- ii) Then apply a test voltage source at the input
- iii) Then find the resulting current at the input
- iv) Then take the ratio of the input voltage and the input current

$$R_{in} = \frac{V_{in}}{i_g} = \infty \quad \longrightarrow \quad \infty \text{ for the CS amplifier (at DC)}$$

This result is somewhat artificial since at non-zero frequencies there will be a finite input current due to capacitances

The Common Source Amplifier: Output Resistance

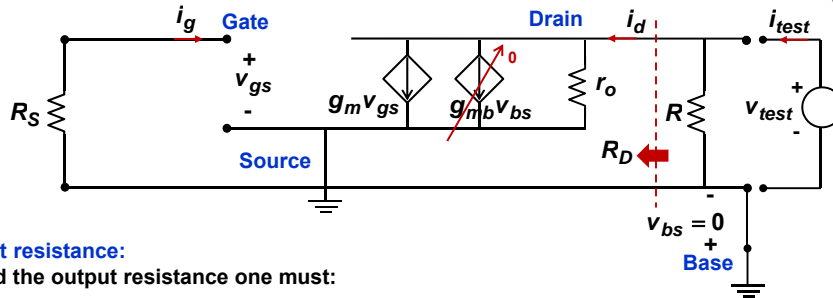

Output resistance:

To find the output resistance one must:

- i) Remove the load resistance R_L and put a test voltage source in its place
- ii) Make sure the source resistance R_S is in place at the input
- iii) Then find the resulting test current at the output
- iv) Then take the ratio of the test voltage and the test current

$$R_{out} = \frac{V_{test}}{i_{test}} = r_o \parallel R \quad \longrightarrow \quad \text{Fairly large for the CS amplifier}$$

Analysis shows that CS is a good transconductance amplifier!

Resistance looking into the drain end of a FET:

$$R_D = r_o$$

The Common Source Amplifier: Complete Two-Port Model

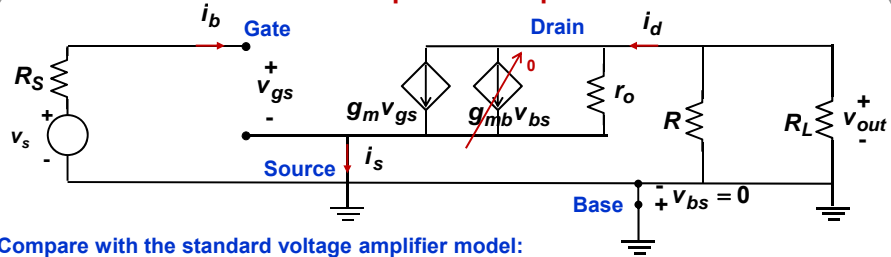

Compare with the standard amplifier model:

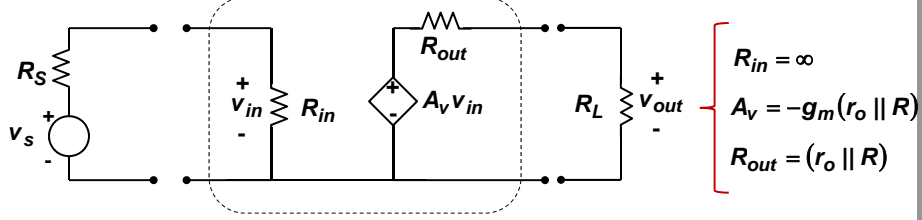

$$\left. \begin{aligned} R_{in} &= \infty \\ A_v &= -g_m(r_o \parallel R) \\ R_{out} &= (r_o \parallel R) \end{aligned} \right\}$$

Now we can use the standard expression:

$$\frac{v_{out}}{v_s} = A_v \left(\frac{R_{in}}{R_{in} + R_S} \right) \left(\frac{R_L}{R_{out} + R_L} \right) = -g_m(r_o \parallel R) \left(\frac{R_L}{(r_o \parallel R) + R_L} \right)$$

The Common Source Amplifier: Complete Two-Port Model

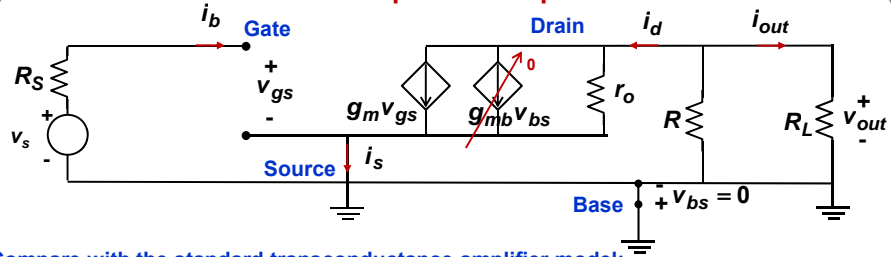

Compare with the standard transconductance amplifier model:

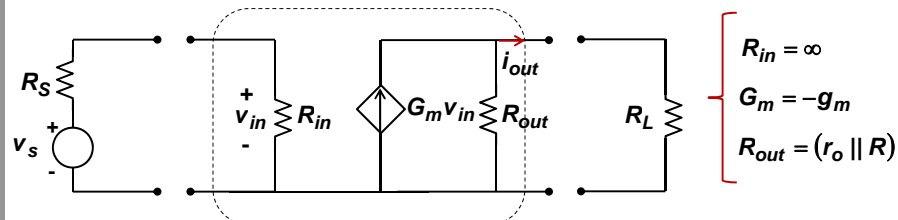

$$\left. \begin{aligned} R_{in} &= \infty \\ G_m &= -g_m \\ R_{out} &= (r_o \parallel R) \end{aligned} \right\}$$

Now we can use the standard expression:

$$\frac{i_{out}}{v_s} = G_m \left(\frac{R_{in}}{R_{in} + R_S} \right) \left(\frac{R_{out}}{R_{out} + R_L} \right) = -g_m \left(\frac{(r_o \parallel R)}{(r_o \parallel R) + R_L} \right)$$

The Common Source Amplifier: g_m vs g_o

In saturation:

$$g_m = k_n(V_{GS} - V_{TN})(1 + \lambda_n V_{DS})$$

$$g_o = \frac{k_n}{2}(V_{GS} - V_{TN})^2 \lambda_n$$

Therefore:

$$\frac{g_m}{g_o} = g_m r_o = \frac{2(1 + \lambda_n V_{DS})}{(V_{GS} - V_{TN})^2 \lambda_n} \approx \frac{2}{(V_{GS} - V_{TN}) \lambda_n}$$

Rough Estimates:

$$(V_{GS} - V_{TN}) \sim 0.5 - 1.0 \text{ V}$$

$$\lambda_n \sim 0.05 - 0.10 \text{ V}^{-1}$$

Therefore:

$$\frac{g_m}{g_o} = g_m r_o \approx \frac{2}{(V_{GS} - V_{TN}) \lambda_n} \sim 20 - 80$$

The Common Source Amplifier with Source Degeneration

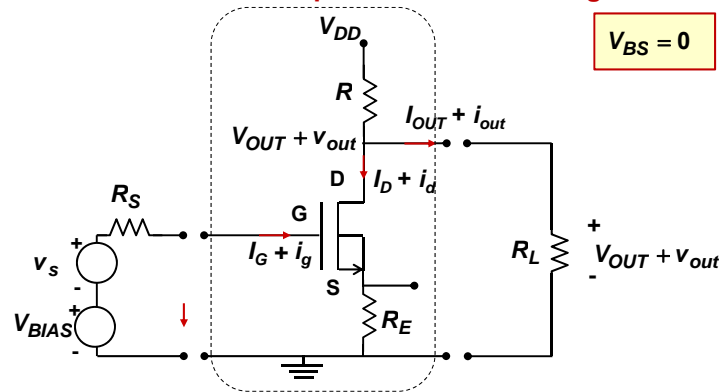

$$V_{DD} - (I_{OUT} + I_D)R = V_{OUT}$$

$$\Rightarrow V_{DD} - \left(\frac{V_{OUT}}{R_L} + I_D \right) R = V_{OUT}$$

$$\Rightarrow V_{OUT} = (V_{DD} - I_D R) \frac{R_L}{R + R_L}$$

$$I_D = \frac{k_n}{2}(V_{GS} - V_{TN})^2(1 + \lambda_n V_{OUT})$$

$$I_D \approx \frac{k_n}{2}(V_{GS} - V_{TN})^2$$

$$V_{GS} = V_{BIAS} - I_D R_E$$

CS Amplifier with Source Degeneration: Open Circuit Voltage Gain

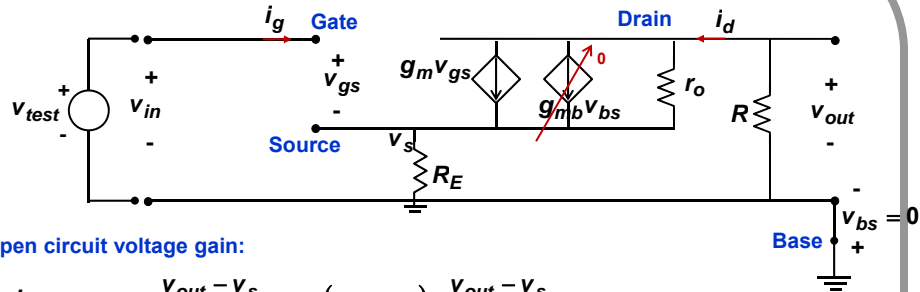

Open circuit voltage gain:

$$i_d = g_m v_{gs} + \frac{v_{out} - v_s}{r_o} = g_m (v_{in} - v_s) + \frac{v_{out} - v_s}{r_o}$$

$$\Rightarrow i_d = g_m (v_{in} - i_d R_E) + \frac{-i_d R - i_d R_E}{r_o} = g_m v_{in} - i_d g_m R_E - i_d \frac{R + R_E}{r_o}$$

$$\Rightarrow i_d = \frac{g_m}{\left(1 + \frac{R + R_E}{r_o} + g_m R_E\right)} v_{in}$$

A_v is reduced when R_E is present

$$\Rightarrow A_v = \frac{v_{out}}{v_{in}} = \frac{-i_d R}{v_{in}} = -\frac{g_m R r_o}{(r_o + R + R_E(1 + g_m r_o))} = -\frac{g_m (r_o \parallel R)}{\left(1 + \frac{R_E}{r_o + R}\right)(1 + g_m r_o)} v_{in}$$

CS Amplifier with Source Degeneration: Transconductance Gain

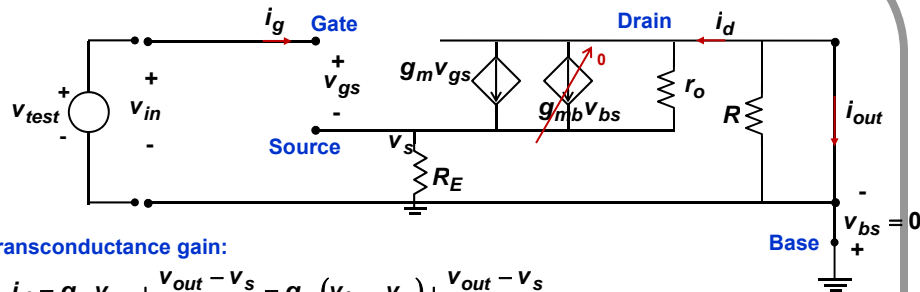

Transconductance gain:

$$i_d = g_m v_{gs} + \frac{v_{out} - v_s}{r_o} = g_m (v_{in} - v_s) + \frac{v_{out} - v_s}{r_o}$$

$$\Rightarrow i_d = g_m (v_{in} - i_d R_E) + \frac{0 - i_d R_E}{r_o} = g_m v_{in} - i_d g_m R_E - i_d \frac{R_E}{r_o}$$

$$\Rightarrow i_d = \frac{g_m}{\left(1 + \frac{R_E}{r_o} + g_m R_E\right)} v_{in}$$

G_m is reduced when R_E is present

$$\Rightarrow G_m = \frac{i_{out}}{v_{in}} = \frac{-i_d}{v_{in}} = -\frac{g_m r_o}{(r_o + R_E(1 + g_m r_o))} = -\frac{g_m}{\left(1 + \frac{R_E}{r_o}\right)(1 + g_m r_o)}$$

CS Amplifier with Source Degeneration: Output Resistance

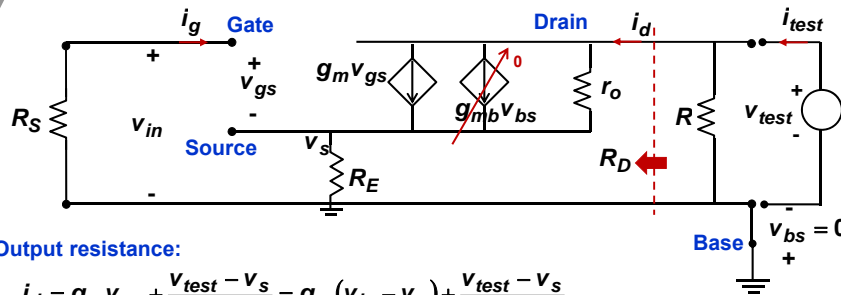

Output resistance:

$$i_d = g_m v_{gs} + \frac{v_{test} - v_s}{r_o} = g_m (v_{in} - v_s) + \frac{v_{test} - v_s}{r_o}$$

$$\Rightarrow i_d = g_m (i_g R_S - i_d R_E) + \frac{v_{test} - i_d R_E}{r_o} = -i_d \left(g_m + \frac{1}{r_o} \right) R_E + \frac{v_{test}}{r_o}$$

$$\Rightarrow i_d = \frac{v_{test}}{r_o + R_E (1 + g_m r_o)}$$

$$\Rightarrow R_D = \frac{v_{test}}{i_d} = r_o + R_E (1 + g_m r_o) \quad \leftarrow R_D \text{ is increased when } R_E \text{ is present}$$

$$\Rightarrow R_{out} = \frac{v_{test}}{i_{test}} = (R \parallel R_D) = \frac{R [r_o + R_E (1 + g_m r_o)]}{r_o + R + R_E (1 + g_m r_o)}$$

Relations to Remember

For any small signal amplifier model, the following always hold:

$$\text{(Transconductance)} \times \text{(Output resistance)} = \text{(Open circuit voltage gain)}$$

$$\text{(Transimpedance)} / \text{(Output resistance)} = \text{(Short circuit current gain)}$$

The above follows from the equivalent Thevenin and Norton models of the amplifier

***All quantities must be calculated assuming the same value of R_s (typically zero)

