

# Understand GPON Technology

## Contents

[Introduction](#)

[Prerequisites](#)

[Requirements](#)

[Components Used](#)

[Background Information](#)

[Terminology](#)

[Network Diagram](#)

[Technology Overview](#)

[GPON Limits](#)

[Power Budgeting](#)

[Packet Walk](#)

[Downstream Packet Walk](#)

[Upstream Packet Walk](#)

[Functional Blocks](#)

[Protocol Stacks](#)

[Important Techniques](#)

[Ranging](#)

[Burst Technology](#)

[Dynamic Bandwidth Allocation \(DBA\)](#)

[Forward Error Correction \(FEC\)](#)

[Line Encryption](#)

[Network Protection Modes](#)

[Related Information](#)

## Introduction

This document describes the Gigabit Passive Optical Network (GPON) technology and how it functions.

## Prerequisites

None.

## Requirements

There are no specific requirements for this document.

## Components Used

This document is not restricted to specific software and hardware versions.

The information in this document was created from the devices in a specific lab environment. All of the devices used in this document started with a cleared (default) configuration. If your network is live, ensure that you understand the potential impact of any command.

## Background Information

GPON is an alternative to Ethernet switching in campus networking. GPON replaces the traditional three-tier Ethernet design with a two-tier optic network by eliminating access and distribution Ethernet switches with passive optical devices. Cisco is introducing GPON with the Catalyst GPON platform.

## Terminology

- **Gigabit-capable Passive Optical Network (GPON)** - Standard for passive optical networks (PON) published by the ITU-T
- **Optical Distribution Network (ODN)** - The physical fibre and optical devices that distribute signals to users in a telecommunications network. The ODN is composed of passive optical components (POS), such as optical fibers, and one or more passive optical splitters.
- **Optical Network Termination (ONT) /Optical Network Units (ONU)** - Connects end-user devices (desktop, phones, etc) into the GPON network. Provides the optical to electrical signal conversion. ONTs also provide AES encryption via ONT key.
- **Splitters** - Used to aggregate or multiplex fiber optic signals to a single upstream fiber optical cable. Usually 1:32 ratio.
- **Optical Line Terminal (OLT)** - Device that aggregates all optical signals from ONTs into a single multiplexed beam of light when is then converted into an electrical signal, formatted to Ethernet packet tpe standards for Layer 2 or Layer 3 forwarding.
- **Wavelength-Division Multiplexing (WDM)** - wavelength-division multiplexing (WDM) is a technology which multiplexes a number of optical carrier signals onto a single optical fiber by using different wavelengths (i.e., colors) of laser light.
- **GEM G-PON encapsulation method (GEM)** - A data frame transport scheme used in gigabit capable passive optical network (G-PON) systems that is connection-oriented and that supports fragmentation of the user data frames into variable-sized transmission fragments
- **Fiber to the X (FTTX)** - FTTX is a generalization for several configurations of fiber deployment, arranged into two groups: FTTP/FTTH/FTTB (Fiber laid all the way to the premises/home/building) and FTTC/N (fiber laid to the cabinet/node, with copper wires to complete the connection).
- **T-CONT/TCONT** - Transmission Container
- **OMCC** - Optical Network Unit Management and Control Channel
- **OMCI** - Optical Network Unit Management and Control Interface
- **PCBd** - Physical Control Block downstream
- **TDM** - Time Division Multiplexing
- **TDMA** - Time Division Multiple Access

## Network Diagram

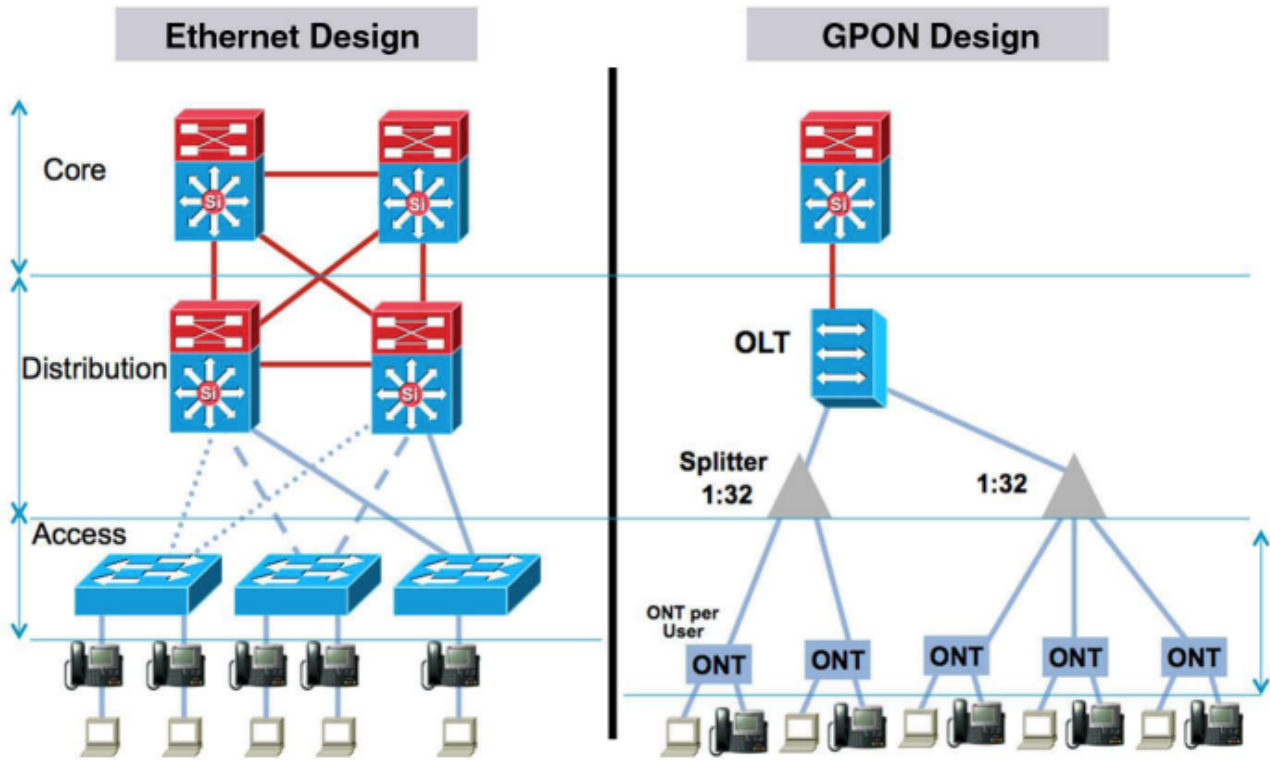

## Technology Overview

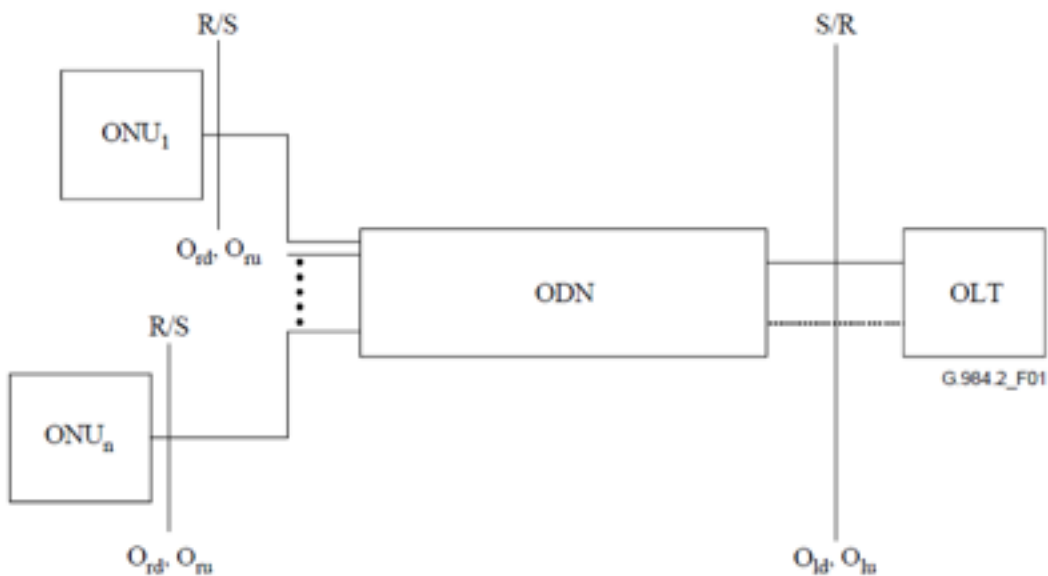

R and S            Reference points  
 $O_{rd}$ ,  $O_{ru}$ ,  $O_{ld}$ ,  $O_{ln}$     Optical interfaces  
 —————            Represent one or more fibre  
 .....                 Represent optional protection fibres



- The OLT is connected to the optical splitter through a single optical fiber, and then the optical splitter connects to ONUs/ONTs.

- GPON adopts WDM to transmit data of different upstream/downstream wavelengths over the same ODN. Wavelengths range from **1290 - 1330 nm** in the **upstream direction** and from **1480 - 1500 nm** in the **downstream direction**.
- Data is **broadcast** in the **downstream direction** and in the **upstream direction** data is **burst** in TDMA mode (based on timeslots).
- Supports point-to-multipoint (P2MP) multicast transmission.

## GPON Limits

- Maximum logical reach: 60 km (This is the maximum distance managed by the higher layers of the system (MAC, TC, Ranging), in view of a future physical media dependent (PMD) specification.
- Maximum fiber distance between send/receive (S/R) and receive/send (R/S) points: 20 km
- Maximum differential fiber distance: 20km
- Split ratio: Restricted by path loss, PON with passive splitters (16,32, or 64 way split)
- Rate: 1.24416 Gigabits/s up, 2.48832 Gigabits/s down

## Power Budgeting

As part of GPON, loss of optical power must be accounted for. This loss can be introduced in a variety of ways, such as:

- Loss within splitters
- Loss per km of fiber (About 0.35 dB per km for 1310, 1490 nm)
- Loss in splices ( > 0.2 dB)
- Connector loss (0.6 dB)
- Fiber bending

**As shown in the image**, the amount of loss incurred from use of various splitters:

Optical Splitters	Loss [dB]
Splitter 1 x 64	20.1
Splitter 1 x 32	17.4
Splitter 1 x 16	13.8
Splitter 1 x 8	10.5
Splitter 1 x 4	7.0

As shown in the image, the minimum and maximum optical path loss per class:

Table G.984.2 – Classes for optical path loss

	Class A	Class B	Class B+	Class C
<b>Minimum loss</b>	<b>5 dB</b>	<b>10 dB</b>	<b>13 dB</b>	<b>15 dB</b>
<b>Maximum loss</b>	<b>20 dB</b>	<b>25 dB</b>	<b>28 dB</b>	<b>30 dB</b>
<p><b>NOTE</b> – The requirements of a particular class may be more stringent for one system type than for another, e.g. the class C attenuation range is inherently more stringent for TCM systems due to the use of a 1:2 splitter/combiner at each side of the ODN, each having a loss of about 3 dB.</p>				

## Packet Walk

### Downstream Packet Walk

As shown in the image, packets go downstream from the OLT towards various ONUs.

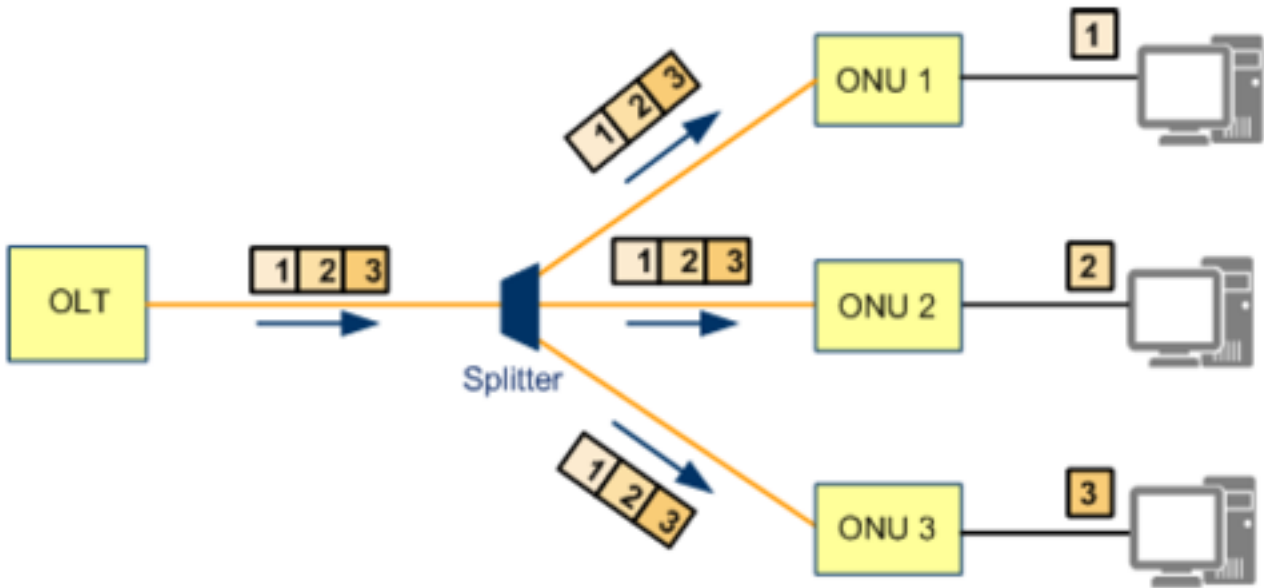

**Tip:** Downstream is from the perspective of the splitter, you can think of it as traffic headed towards the ONU/ONT, or end users.

- Downstream packets are forwarded as **broadcasts**, with the same data sent to all the same ONU/ONT with different data identified by the GEM port ID.
- Allows an ONU/ONT to receive the desired data by **ONU ID**.
- Downstream wavelength range is from **1480 - 1500nm**.
- **Downstream continuous mode operation** - Even where there is no user traffic passed through GPON, there is a constant signal, except when the laser is administratively turned off.

As shown in the image, the procedure of downstream packet forwarding.

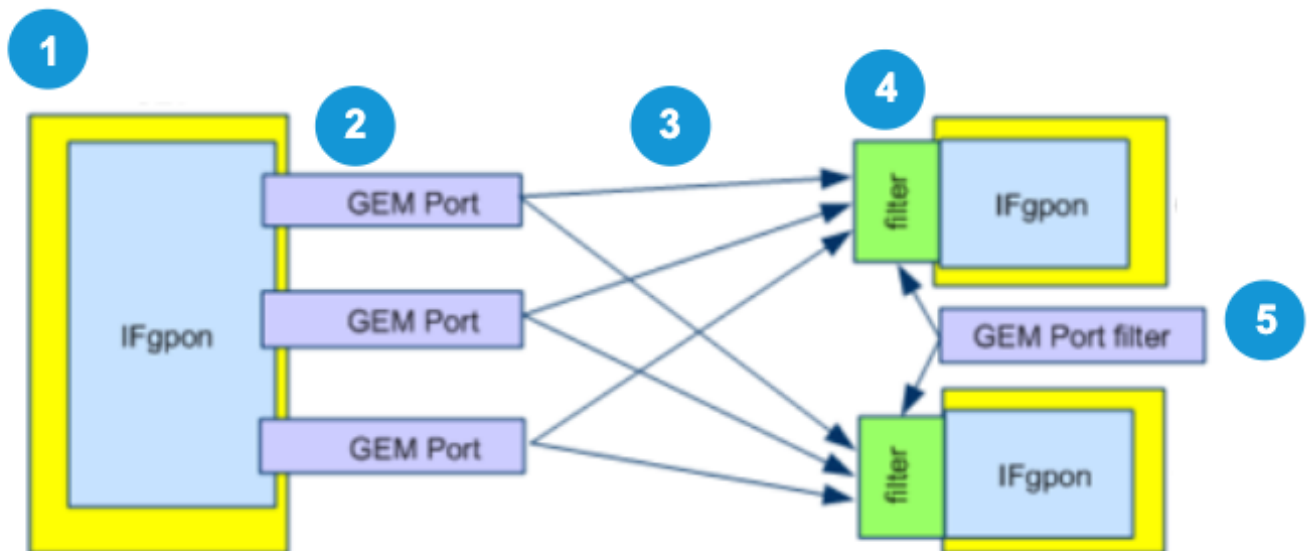

1. OLT sends Ethernet frames from Uplink ports to the GPON service processing module

based on configured rules to the PON ports.

2. GPON service processing module then encapsulates the Ethernet frames into GEM port data packets for downstream transmission.
3. GPON transmission convergence (GTC) frames that contain GEM PDUs are broadcast to all ONT/ONUs connected to the GPON port.
4. ONT/ONU filters the received data based on the GEM port ID contained in the GEM PDU header and retains the data only significant to the GEM ports on this ONT/ONU.
5. ONT decapsulates the data and sends the Ethernet frames to the end users via service ports.

### Downstream Packet Frame Structure

- A downstream GPON frame has a fixed length of 125 s, comprised of two components: physical control block downstream (PCBd) and payload.
- The OLT broadcasts PCBd to all ONU/ONTs. The ONU/ONTs receive the PCBd and performs operations based on the information received.
- PCBd consists of the GTC header and BWmap:

GTC Header - Used for frame delimitation, synchronization, and forward error correction (FEC)

BWmap - Field notifies every ONU of upstream bandwidth allocation. Specifies the start and end upstream time slots for the T-CONTs of each ONU, this ensures that all ONUs send data based on the time slots specified by the OLT to prevent data conflict.

**As shown in the image**, an expanded view of the PCBd and what is contained within the GTC payload.

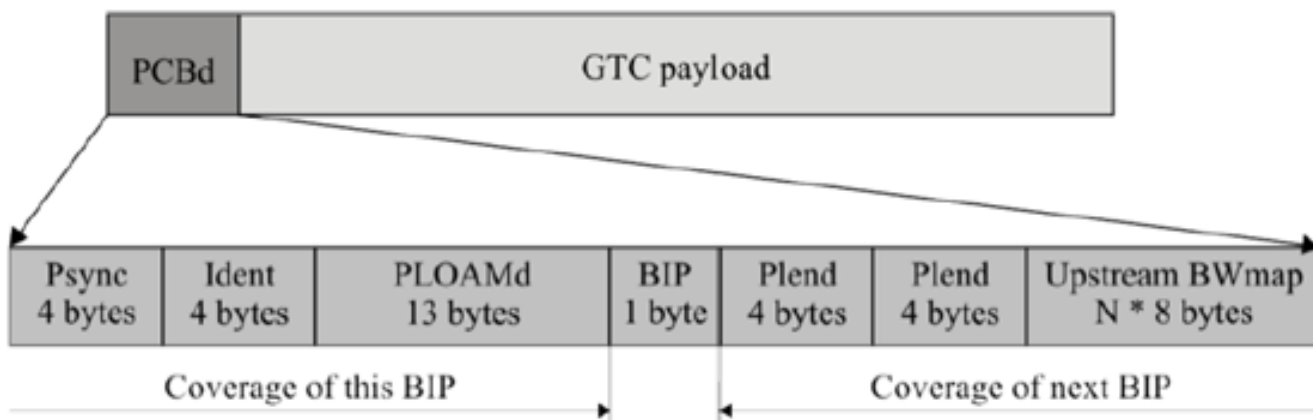

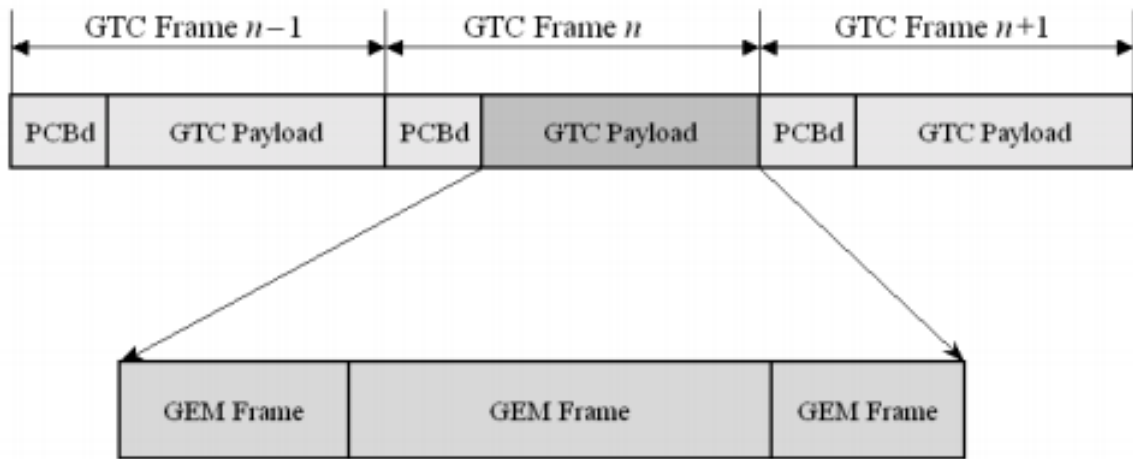

G.984.3\_FB-2

## Key Terms:

- **Psync** (4 byte length) - Physical synchronization field, indicates the start of every PCBd
- **Ident** (4 byte length) - Used to indicate larger frame structures, contains the superframe counter which is employed by the encryption system
- **PLOAMd** (13 byte length) - Physical layer OAM (PLOAM) downstream field, think of this as a message-based operation and management channel between the OLT and ONU/ONTs
- **BIP** (1 byte length) - Bit-interleaved parity, by the receiver to measure the number of errors on the link
- **Plend** (4 byte length) - Payload length downstream field

## Upstream Packet Walk

As shown in the image, upstream packet flow from various ONUs to the OLT.

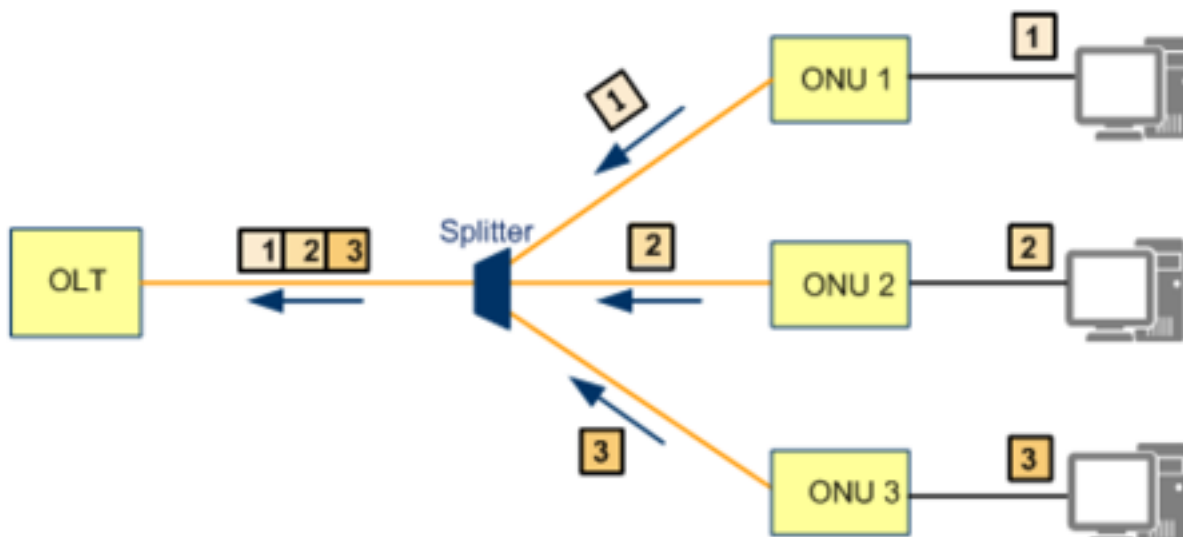



**Tip:** Upstream can be thought of from the perspective of the splitter, or traffic sent from the ONU/UNT, end users towards the OLT.

- Upstream packet transmission occurs through TDMA (time division multiple access)

Distance between the OLT and ONT/ONU is measured

Time slots are allocated based on distance

ONT/ONU sends traffic upstream based on granted time slot

- Dynamic Bandwidth Allocation (DBA) enables the OLT to monitor in real-time, congestion, bandwidth usage, and configuration.
- Detects and prevents collisions through ranging
- Upstream wavelength ranges from 1290 - 1330 nm

**As shown in the image,** the procedure of upstream packet forwarding.

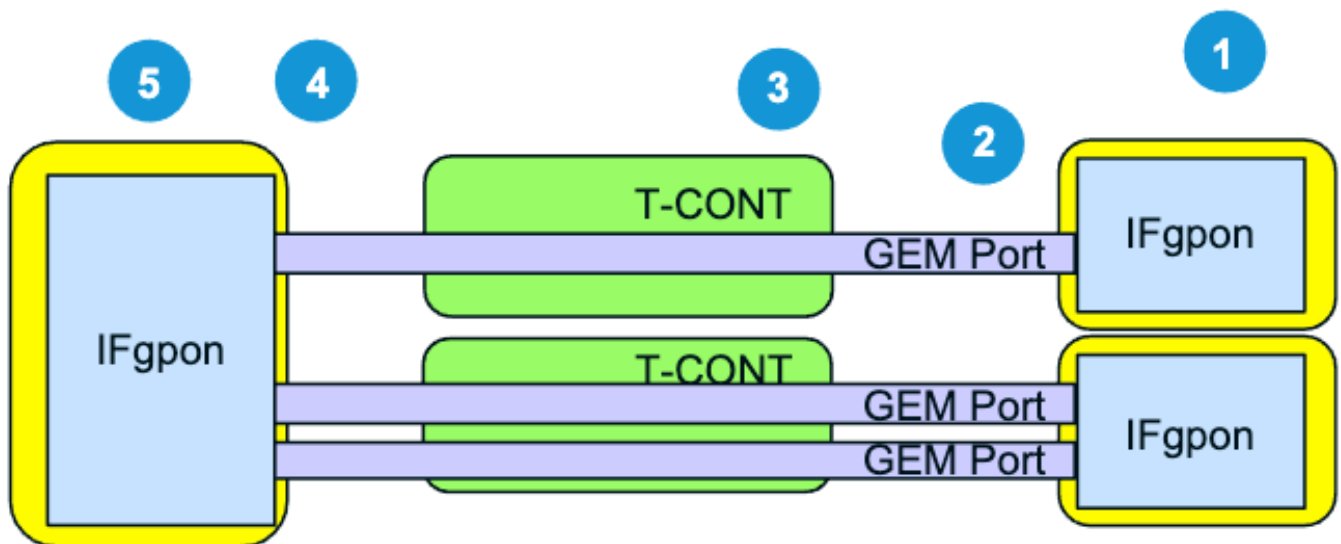

1. ONT/ONU send Ethernet frames to GEM ports based on based on configured rules that map service ports and GEM ports.
2. GEM ports encapsulate the Ethernet frames into GEM PDUs and add these PDUs to TCONT queues based on rules that map GEM ports and TCONT queues.
3. TCONT queues use time slots based on DBA, then transmit upstream GEM PDUs to the OLT.
4. OLT decapsulates the GEM PDU, the original Ethernet frame is now seen.
5. OLT sends the Ethernet frames from a specified uplink port based on rules that map service ports and uplink ports.

### Upstream Packet Frame Structure

- Each upstream GPON frame has a fixed length of 125  $\mu$ s.
- Each upstream frame contains the content carried by one or more T-CONT/TCONTs
- All ONUs connected to a GPON port share the upstream bandwidth
- All ONUs send their data upstream at their own time slots based on bandwidth map (BWmap) requirements.
- Each ONU reports the status of data to be sent to the OLT by use of upstream frames. OLT uses DBA to allocate upstream time slots to ONUs and sends updates in each frame.

**Note:** Upstream frames are sent as bursts, which is comprised of the upstream physical layer overhead (PLOu) and one or more bandwidth allocation interval(s) associated with a specific Alloc-ID

As shown in the image, the difference between a downstream and upstream frame.

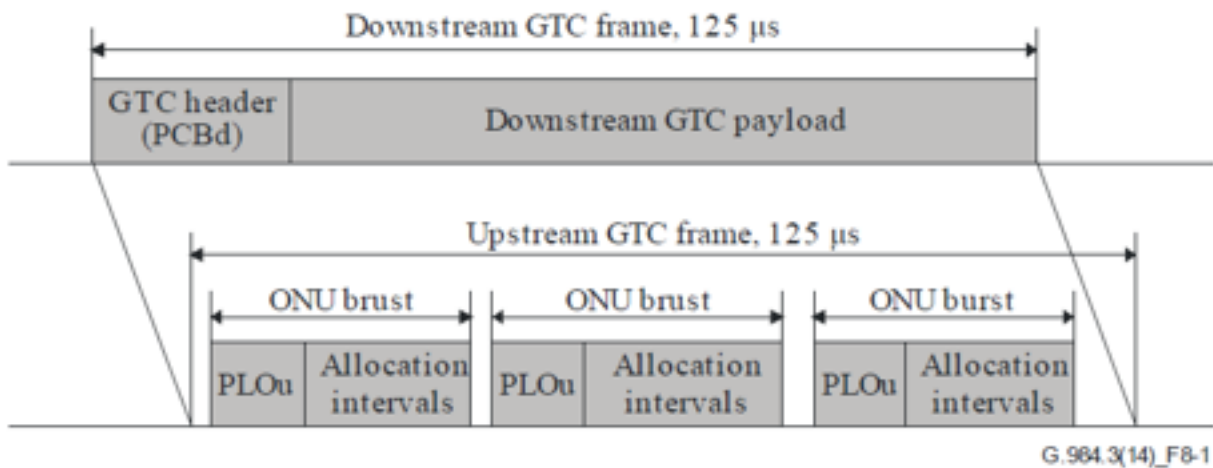

### Key Terms:

- Physical layer overhead upstream (PLOu) - Upstream physical layer overhead
- Physical layer OAM upstream (PLOAMu) - PLOAM messages of upstream data. think of this as a message-based operation and management channel between the OLT and ONU/ONTs.
- Power level sequence upstream (PLSu) - Upstream power level sequence
- Dynamic bandwidth report upstream (DBRu) - Upstream dynamic bandwidth report
- Payload - User data

## Functional Blocks

### OLT Functional Blocks

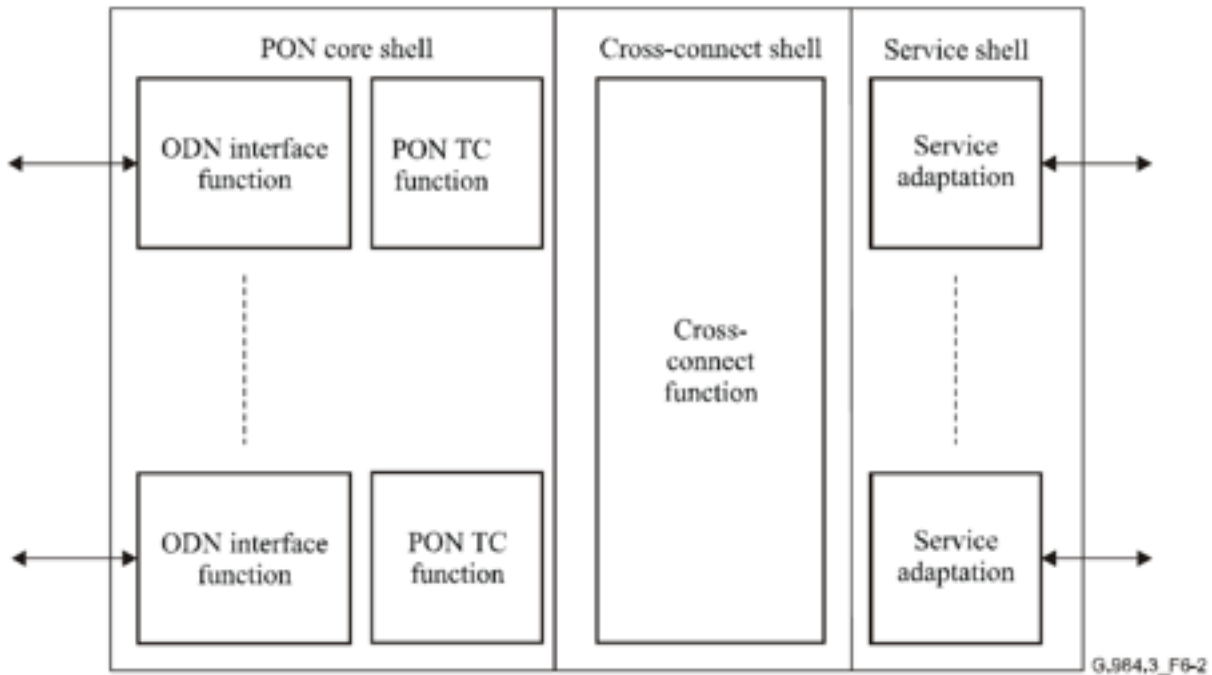

An OLT consists of **three** major parts:

- **Service port interface function** - Provides translation between service interfaces and the TC frame interface of the PON section.
- **Cross-connect function** - Provides a communication path between the PON shell and the Service shell, as well as cross-connect functionality.
- **Optical Distribution Network (ODN) interface** - Further subdivided into two parts:

#### **PON interface function**

**PON TC function** - Responsibilities include framing, media access control, OAM, DBA, and delineation of the Protocol Data Unit (PDU) for the cross connect function, and ONU management.

#### **ONU/OLT Functional Blocks**

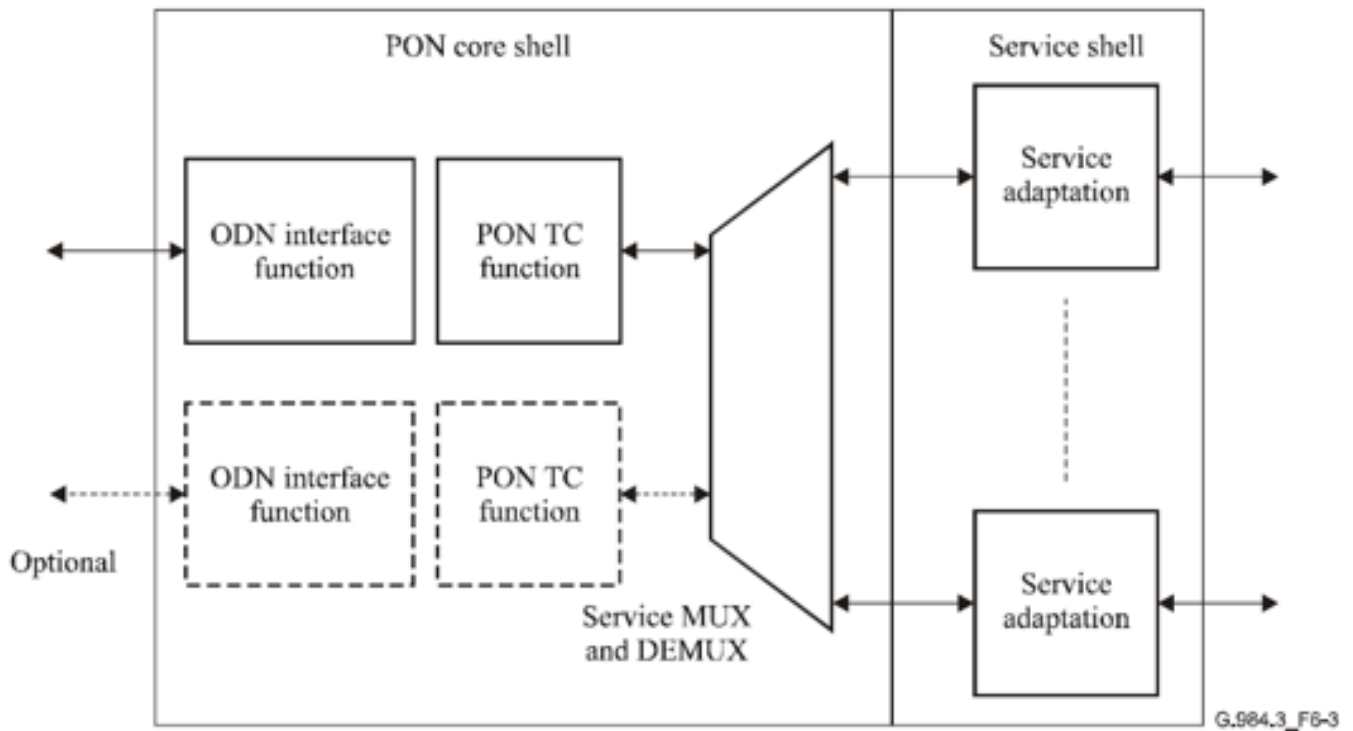

Functional blocks are similar to the OLT. In the scenario that the ONU/OLT operates with a single PON interface (max 2 for protection purposes) the cross-connect function is omitted. Instead of this function, the service MUX and DEMUX are now responsible for traffic.

## Protocol Stacks

The GPON protocol has its own stack, just Ethernet or IP.

**As shown in the image**, the protocol stack for GPON:

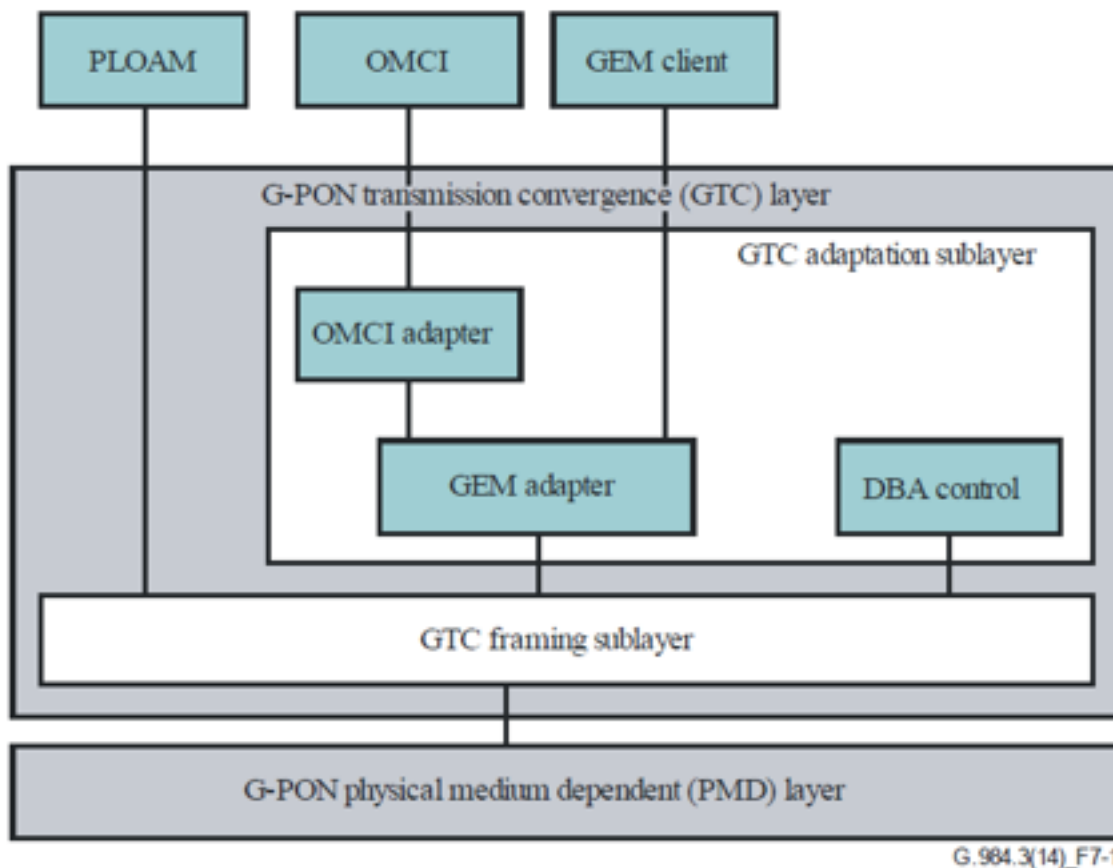

### Key Terms:

- **PMD Layer** - Equivalent to the GPON interfaces that sit between the OLTs and the ONUs.
- **GTC Layer** - Responsible for encapsulation of payloads by use of ATM cells or GEM frames. GEM frames can carry Ethernet, POTS, E1, and T1 cells.

### Traffic Mapping - Ethernet

- Resolves Ethernet frames and directly map the data of Ethernet frames into the GEM payload
- GEM frames automatically encapsulate header information
- 1:1 alignment between an Ethernet Frame and GEM Frame

As shown in the image, how an Ethernet frame is mapped to a GEM frame:

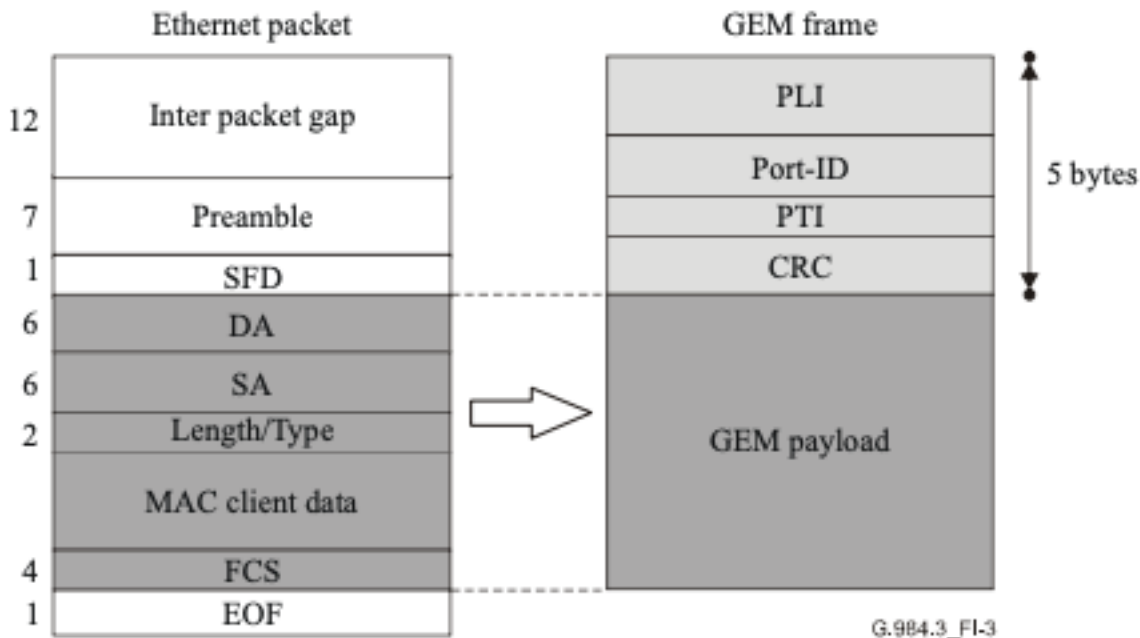

## OMCI

- ONU Management and Control Interface (OMCI) messages are used to discover ONT/ONUs for management and control.
- These specialized messages are sent over dedicated GEM ports established between an OLT and an ONT/ONU.
- The OMCI protocol allows an OLT to:

Establish and release connections with the ONT

Manage the UNIs on the ONT

Request configuration information and performance statistics

Autonomously alert of events, such as a link failure

## Key Points:

- Protocol runs over a GEM connection between the OLT and ONT
- GEM connection is established while the ONT initializes
- Protocol operation is **asynchronous** - OLT controller functions as a master, ONT controller as slave

## Important Techniques

### Ranging

In order to prevent data conflict (collisions), the OLT must be able to precisely measure the distance between itself and each ONU to provide a proper time slot for to facilitate data upstream. This allows the ONUs to send data at specified time slots, to prevent issues upstream. This process is achieved through a technique called ranging.

### Ranging Process:

- OLT starts the process on an ONU when the ONU first registers with the OLT and obtains round trip delay (RTD) of the ONU. Based on the RTD, the other key components are identified:
- Calculation of the physical reach of that specific ONU, as this OLT requires a proper equalization delay (EqD) for each ONU based on physical reach.
- RTC and EqD synchronize data frames sent by all ONUs

As shown in the image, a demonstration of what the process achieves, to place all ONU/OLTs at the virtual same distance from the OLT.

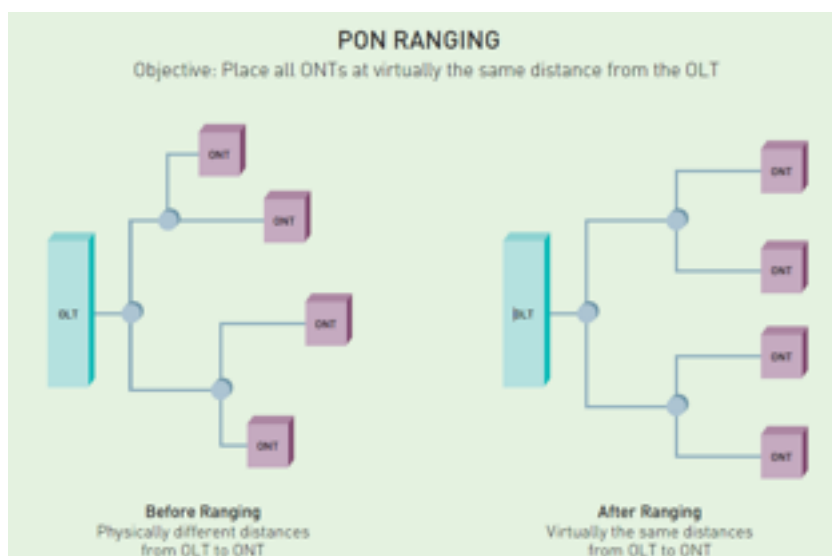
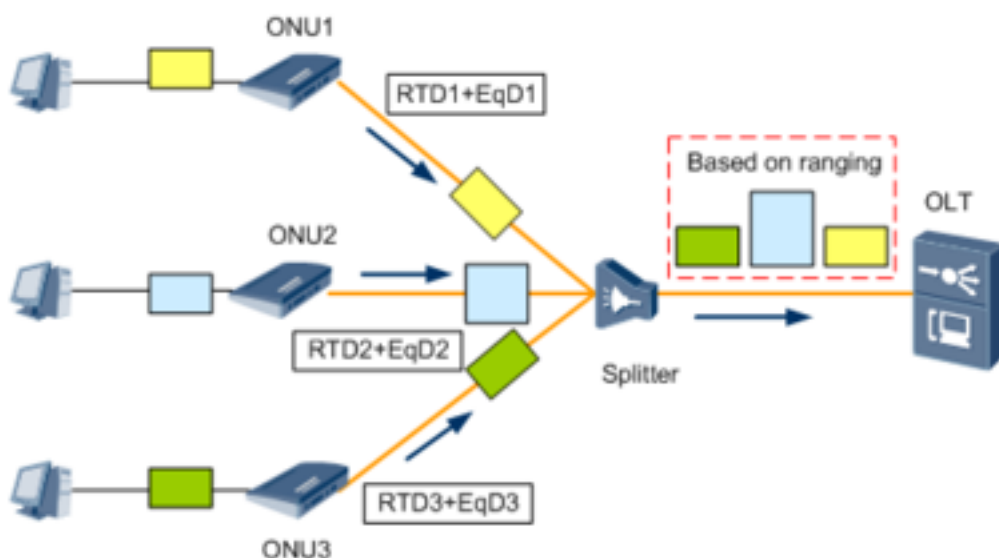

### Burst Technology

Upstream packet flow is achieved via bursts, with each ONU/ONT responsible for data transmission within its allocated time slots. When an ONU/ONT is not within its time slot, the

device disables transmission of its optical transceiver to prevent other ONU/ONT impact.

- Burst transmit function is supported by ONU/ONT modules
- Burst receive function is supported by OLT modules
- Varied distance between each ONU/ONT and OLT results in optical signal attenuation. As a result, power and level of packets received by an OLT vary in different time slots.
- **Dynamic threshold adjustment** enables the OLT to dynamically adjust the threshold for optical power levels. This ensures that all ONU signals can be recovered.

**As shown in the image**, a demonstration of different data burst-transmitted, and then recovered:

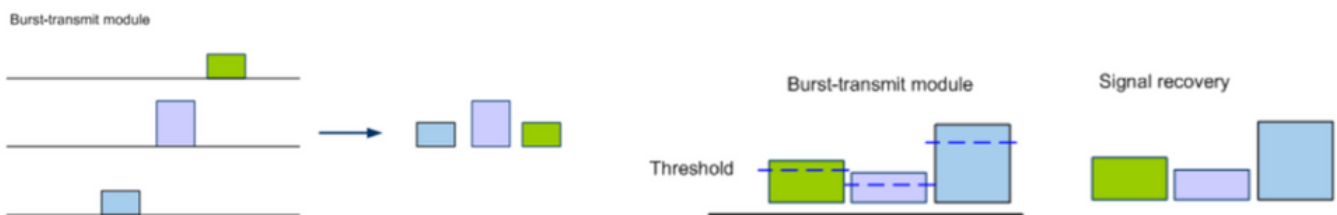

## Dynamic Bandwidth Allocation (DBA)

DBA enables an OLT module to monitor for congestion on the PON network in real-time. This allows the OLT to adjust bandwidth based on a variety of factors, which includes congestion, bandwidth usage, and configuration.

### Key DBA Points:

- Embedded DBA module within the OLT constantly collects DBA reports, performs calculations, and notifies the ONU through the BWMap field within the downstream frame.
- As a result of the BWMap information, the ONU sends data upstream in the time slots allocated to occupy upstream bandwidth.
- Bandwidth can be also allocated in a static/fixed mode
- Usage of the DBA allows:

Improved upstream bandwidth usage on a PON port

Higher bandwidth for users and support for more users on a PON port

## Forward Error Correction (FEC)

Transmission of digital signals can introduce bit errors and jitter, which can degrade signal transmission quality. GPON can take advantage of FEC, which enables the RX end to check for error bits in the transmission.



**Note:**FEC is unidirectional and does not support error information feedback.

### Key FEC Points:

- Does not require data retransmission
- Supports FEC in the downstream direction only
- Improved transmission quality from PCBd and payload processing

### Line Encryption

All downstream data is broadcast to all ONUs. A risk is that unauthorized ONUs receive downstream data meant for authorized ONUs. To combat this, GPON utilizes the AES128 algorithm to encrypt data packets.

### Key Line Encryption Points:

- Use of line encryption does not increase overhead or decrease bandwidth usage
- Use of line encryption does not prolong transmission delays

### Key Exchange and Switchover

- OLT initiates a key exchange request to the ONU. ONU responds to the request with a new key.
- After receipt of the key, the OLT uses the new key to encrypt data
- OLT sends the frame number that users the new key to the ONU
- ONU receives the frame number and switches the verification key on inbound data frames.

As shown in the image, the key exchange process:

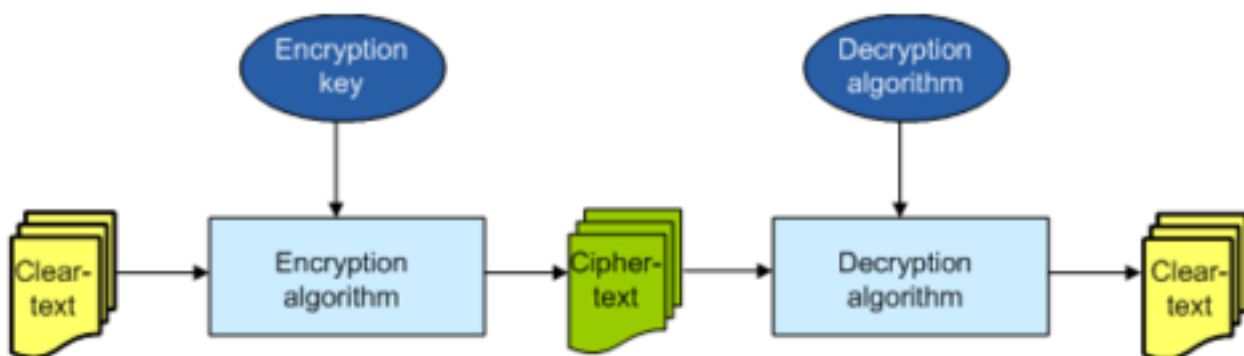

### Network Protection Modes

There are several different types of network protection modes that GPON can utilize, see below

for different types.

### Type A

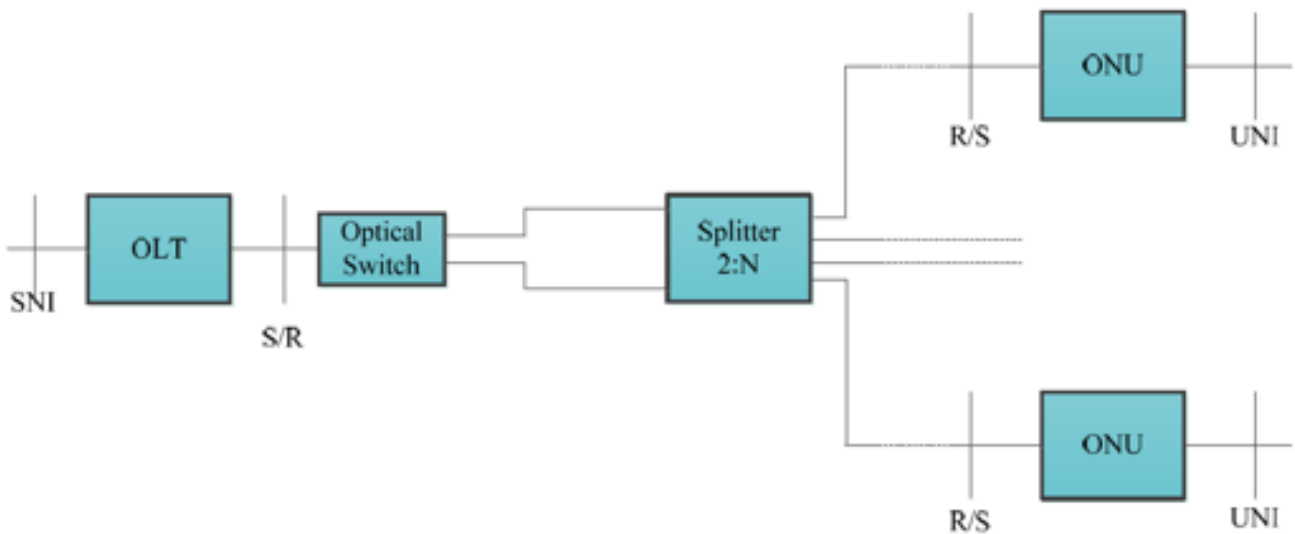

- Does not require an additional OLT PON port
- When primary fiber fails, services are transferred to the secondary fiber
- Outage duration depends on the time of line recovery
- If the failure occurs on the line from splitter to ONU, there is no backup

### Type B

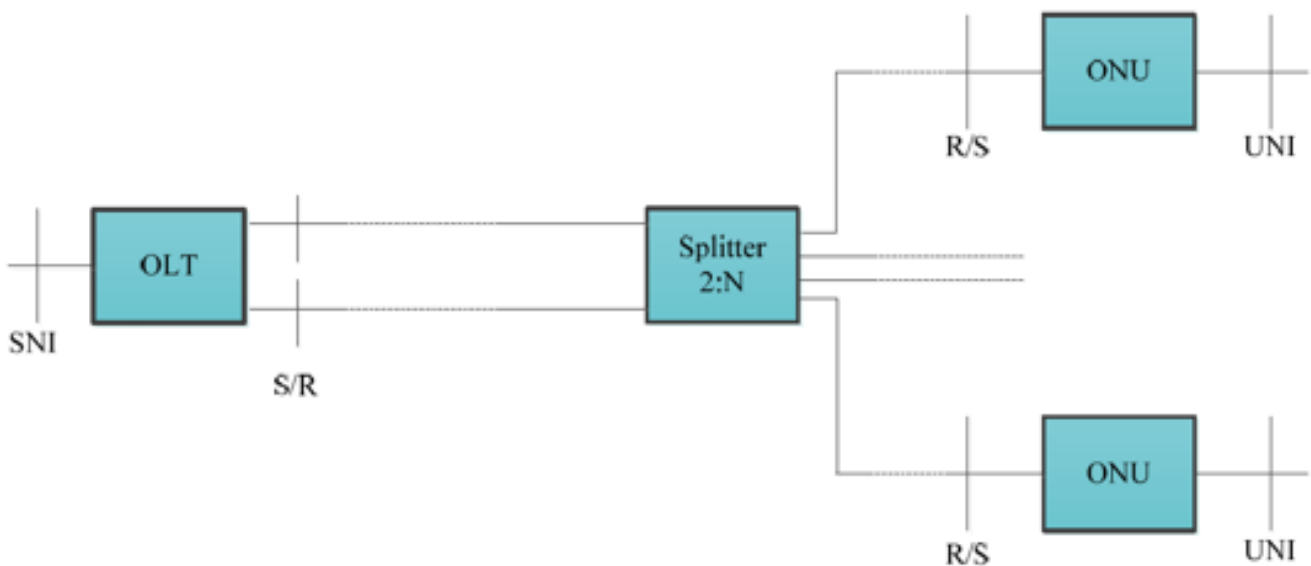

- OLT provides two GPON ports as valid and protection OLTs
- Protection is restricted to the fiber from the OLT to the splitter and boards of the OLT

- No equipment redundancy is provided in the ONU or feeder fibres.
- No ONU or full ODN protection
- Utilizes a 2 x N splitter and without any additional optical loss

## Type C

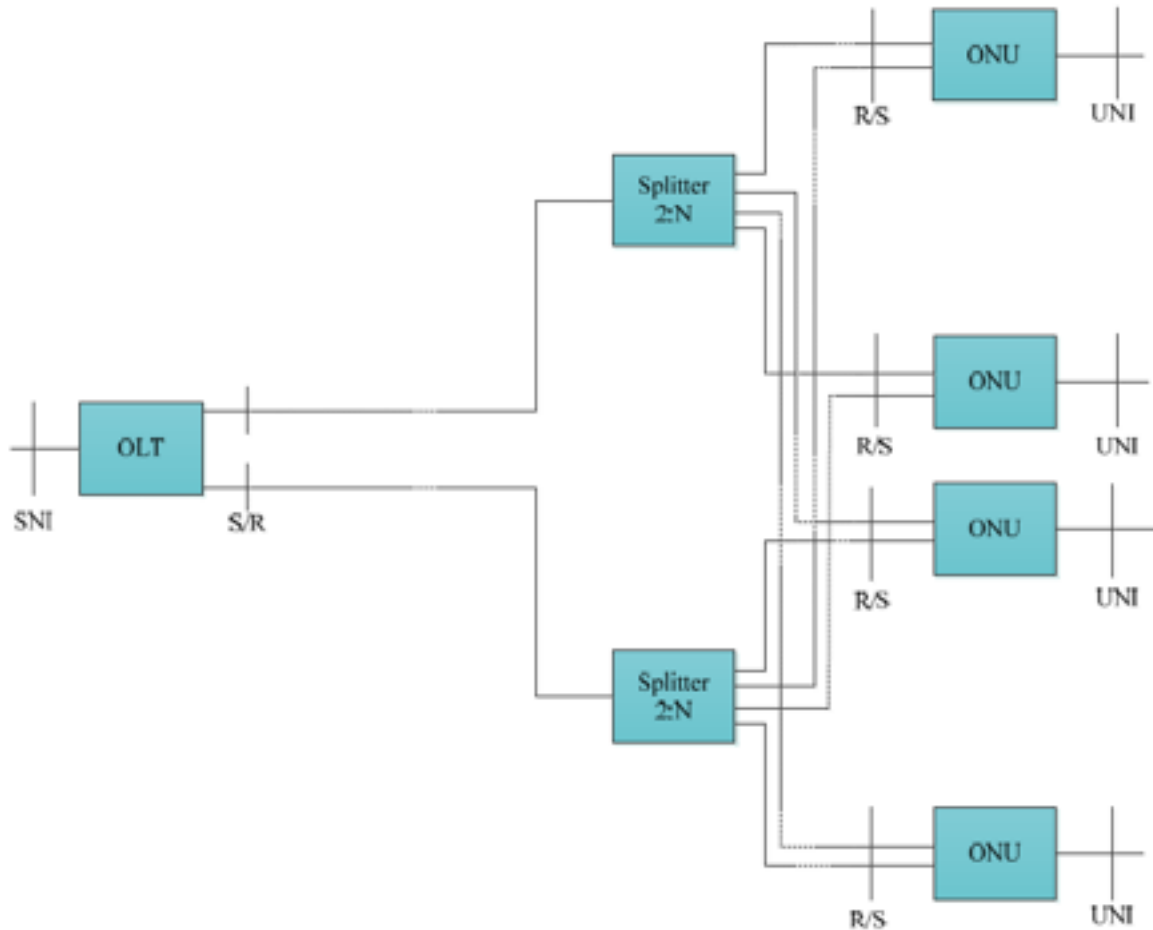

- Redundancy for the OLT, ODN, and ONU(s)
- Provides 2 fully redundant links all the way to the subscriber's premises
- Two options: Linear 1 + 1 and Linear 1:1 protection

### 1+1 Protection:

- The protection PON is dedicated to the valid PON
- Normal traffic is copied and sent to both PONs, with a permanent bridge between the two OLTs
- Traffic is sent to an ONU simultaneously, selection between the two signals is based on predetermined criteria

## **1:1 Protection:**

- Normal traffic is transported either on the valid or protection PON.
- Automatic protection switches between the PONs
- Most costly, but provides maximum availability.

## **Related Information**