

ON Semiconductor®



Energy Efficient Innovations

HBD851/D
Rev. 9B, Feb-2018

Quality & Reliability Handbook

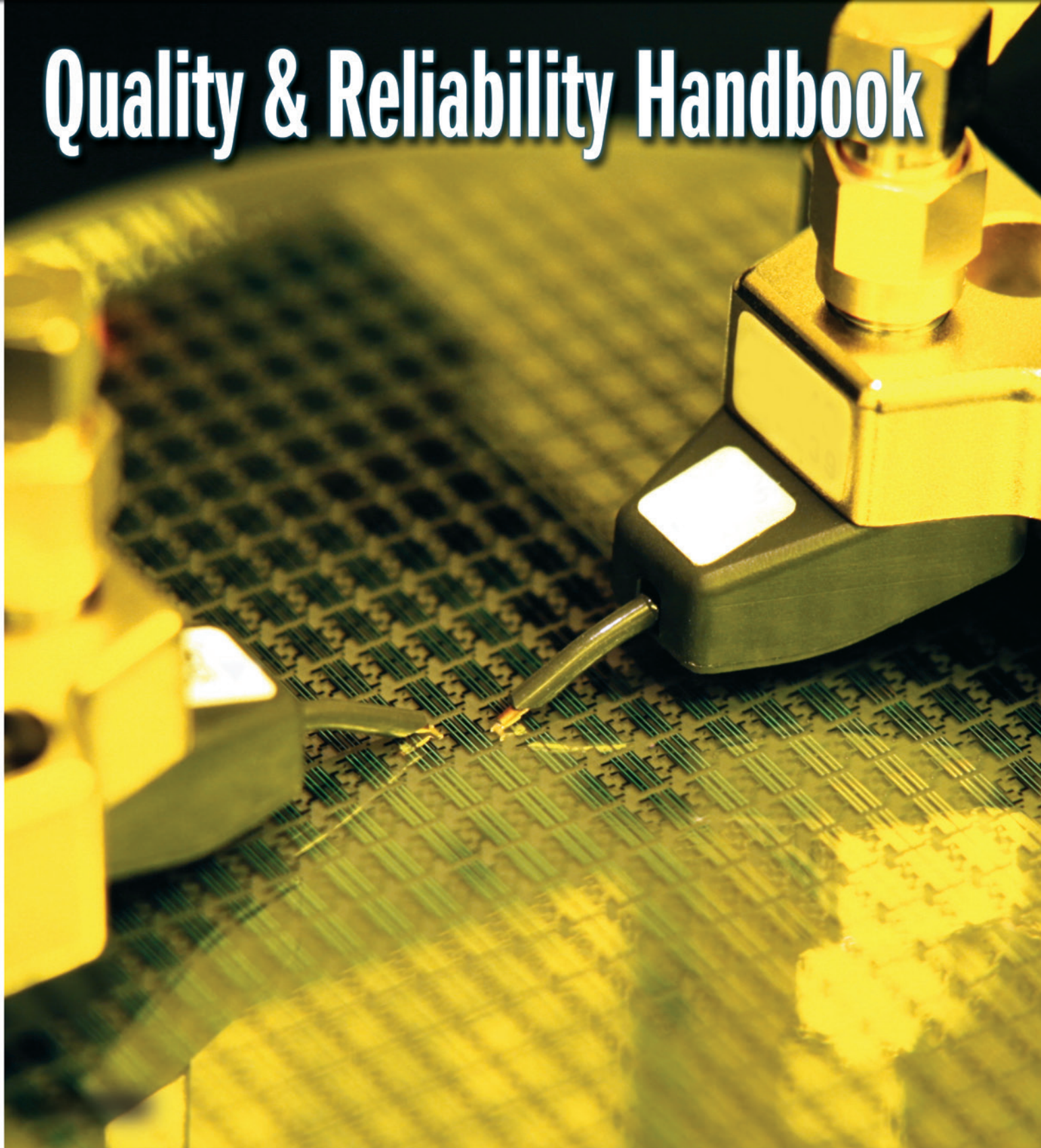

Table of Contents

Introduction	4	External Manufacturing Quality	16
ON Semiconductor Quality System	6	Customer Returns	17
Introduction to Reliability & Quality Methods.	7	New Product Development.	18
Customer Process Change Notification.	12	ISO 26262 Automotive Functional Safety	19
Supplier Quality Process.	13	Storage and Preservation	20
Failure Analysis.	14	ON Semiconductor Corporate Social Responsibility and Sustainability	20
Reliability Data Summary	16		

Dear Customer:

I am pleased to present you with the ON Semiconductor Reliability and Quality Handbook. ON Semiconductor is certified to ISO/TS-16949, AS-9100 as well as ISO-14001, OHSAS 18000 and military standards. We also received distinction by being classified as a 'Trusted Supplier'. Our Road to Zero Defect initiative recognizes the integrated effectiveness of building both "Reliability" and "Quality" into our services, processes and products. We are committed to developing and maintaining a distinctive, world class Quality system, which transcends all international Quality standards and truly exceeds customer expectations. This handbook is intended to provide basic information on the reliability and quality aspects of the products supplied by ON Semiconductor worldwide. ON Semiconductor maintains a portfolio that includes a broad spectrum of products in a full array of package technologies, including but not limited to, the following products:

- **Power Management Devices:** AC-DC Controllers & Regulators; DC-DC Controllers, Converters, & Regulators; LED Drivers; Motors and Load Drivers; Power Modules; Voltage & Current Management
- **Sensor Devices:** Image Sensors & Processors; Light & Touch Sensors; Thermal Management; Battery-Free Wireless Sensors
- **Analog, Logic and Timing Devices:** Amplifiers & Comparators, Clock Generation; Clock & Data Distribution; Interfaces; Memory; Microcontrollers; Standard Logic
- **Discrete Devices:** Bipolar Transistors; Diodes & Rectifiers; ESD, EMI & Surge Protection Diodes & Filters; IGBTs & FETs; Tunable Components
- **Connectivity, Custom and SoC Devices:** Audio/Video ASSP, Connectivity, ASICs; Custom Foundry Services; Customer Image Sensors; Integrated Passive Devices

ON Semiconductor is headquartered in Phoenix, Arizona (U.S.A.) and has a number of international facilities, which have on-site test, reliability testing and product analysis capabilities. ON Semiconductor has developed a global marketing, sales and field quality network to supply its customers with quality products, information and services.

ON Semiconductor's Quality System and Business Operating System are synonymous. The company established a Core Business Process Model to ensure that we meet or exceed our customer's expectations and our business goals. We've adopted the approach of taking international standards and some common customer requirements and aligning them within our existing Business Model.

Our Quality Policy states, "We will exceed Customer Expectations with our Superior Products and Services." In addition, our Quality statement declares, "Every ON Semiconductor employee is personally responsible for ensuring the highest Quality in the products and services delivered to internal and external customers. Continuous improvement in the quality of our processes, products and service is fundamental to the achievement of customer satisfaction." The policy emphasizes that the responsibility to achieve quality, both in services and products belongs to each and every one of us. I cannot over emphasize this point! ALL of us, every business leader, sales person, project manager, operator, engineer, EVERY ON Semiconductor employee, is personally responsible for the Quality of those products and services that we individually and collectively supply to our Customers.

And finally, because we believe "fulfilling customer requirements is the first step in customer satisfaction," our Core Business process model begins with the customer and ends with the customer. The strength of our business initiatives and our focus on servicing our customers ensures ON Semiconductor's success now and in the future.

The recent acquisition of Fairchild Semiconductor Inc. further strengthens ON Semiconductor's position in various markets and applications. In subsequent updates we will include that information into the Quality and Reliability Handbook.

For additional questions, please contact 1 (800) 282-9855 or email us at quality@onsemi.com.

Keenan Evans
Vice-President, Global Quality, Reliability, EHS, and Corporate Social Responsibility
ON Semiconductor

Section 1 – Introduction

ON Semiconductor (Nasdaq: ON) is driving energy efficient innovations, empowering customers to reduce global energy use. The company is a leading supplier of semiconductor-based solutions, offering a comprehensive portfolio of energy efficient power management, analog, sensors, logic, timing, connectivity, discrete, SoC and custom devices. The company's products help engineers solve their unique design challenges in automotive, communications, computing, consumer, industrial, medical, aerospace and defense applications. ON Semiconductor operates a responsive, reliable, world-class supply chain and quality program, a robust compliance and ethics program, and a network of manufacturing facilities, sales offices and design centers in key markets throughout North America, Europe and the Asia Pacific regions. For more information, visit www.onsemi.com.

The company's current portfolio numbers close to 55,000 products which includes full Pb-Free, ROHS compliant device offerings. We shipped more than 55 billion units in 2014, 60 billion units in 2015 and over 70 billion units in 2016. These products are put in the hands of our customers through our highly responsive supply chain. With our global logistics network and strong portfolio of power semiconductor devices, ON Semiconductor is a preferred supplier of power solutions to engineers, purchasing professionals, distributors and contract manufacturers in the computer, cell phone, portable devices, automotive and industrial markets.

Headquartered in Phoenix, Arizona, we are a public company and trade on the NASDAQ under the symbol (ONNN). We employ approximately 32,000 people worldwide and have manufacturing facilities, sales, offices and design centers though out North, America, Asia Pacific and Europe. We strive to continuously meet our customers' current and anticipated semiconductor component needs so well that, "Customers will come to us first!" We enact this vision by each day fulfilling our mission to: Eliminate any reason for the customer to buy from other suppliers by providing the highest Quality components and services at competitive prices with the most reliable delivery and ease of purchase.

ON Semiconductor has various [international certifications](#). The foundation of our success is customer satisfaction, customer confidence and continuous improvement. The extent of these efforts touches every function and region of our business. Our quality resolve is deeply ingrained in every employee.

This handbook is intended to review and provide information on the reliability and quality aspects of the semiconductor products supplied by ON Semiconductor worldwide.

In today's semiconductor marketplace, two important elements for the success of a company are its quality and reliability systems. They are interrelated, reliability being the quality extended over the expected life of the product. For any manufacturer to remain in business, its products must meet or exceed the basic quality and reliability standards. As a semiconductor supplier, ON Semiconductor has successfully established reliability and quality standards for products, processes, and services that exceed the basic standards and meet our customers' needs. For the purpose of this report, the most stringent and demanding definitions of quality and reliability are used.

Quality may be defined as:

- Reduction of variability around a target so that conformance to customer requirements and expectations can be achieved in a cost effective way.
- The probability that a device (equipment, parts) will have performance characteristics within specified limits.
- Fitness for use.

Reliability is defined as:

- Quality in time and environment (temperature, voltage, etc.).
- The probability that a semiconductor device, which initially has satisfactory performance, will continue to perform its intended function for a given time under actual usage environments.



At ON Semiconductor, our reliability and quality assurance program is designed to generate ongoing data for both reliability and quality for the various product families. Both reliability and quality monitors are performed on the different major categories of semiconductor products. These monitors are designed to test the product's design and material as well as to identify and eliminate potential failure mechanisms to ensure reliable device performance in a real world application. Thus, the primary purpose of the program is to identify trends from the data generated and use that information to continuously improve our products. In addition, this reliability and quality data can be utilized by our customers for failure rate predictions.

This handbook is a compilation of reliability test results and quality data from all semiconductor operations. The data contained are annual summaries of many detailed tests and evaluations performed in ON Semiconductor locations worldwide.

Detailed reliability reports for product line or device types are available upon request and can be obtained through your local ON Semiconductor Sales or Customer advocacy representative, or from the sources indicated in this handbook.



Section 2 – ON Semiconductor Quality System

(Based on our Core Business Process Model)

ON Semiconductor is registered to both ISO 9001 and ISO Technical Specification (TS) 16949. ON Semiconductor's Quality System and Business Operating System are synonymous. The company established a Core Business Process Model, which shown below ensures we meet or exceed our customer's expectations and our business goals. We have adopted the approach of taking international standard and common customer requirements and aligning them into our existing Business Model.

Our Quality Policy states, "We will exceed Customer Expectations with our Superior Products and Services." In addition, our Quality statement declares, "Every ON employee is personally responsible for ensuring the highest Quality in the products and services delivered to internal and external customers. Continuous improvement in the quality of our processes, products and service is fundamental to the achievement of customer satisfaction." Since we believe that, in other words, "fulfilling customer requirements is the first step in customer satisfaction", our Core Business process model begins with the customer and ends with the customer.

Customer Business Process Model and Structure

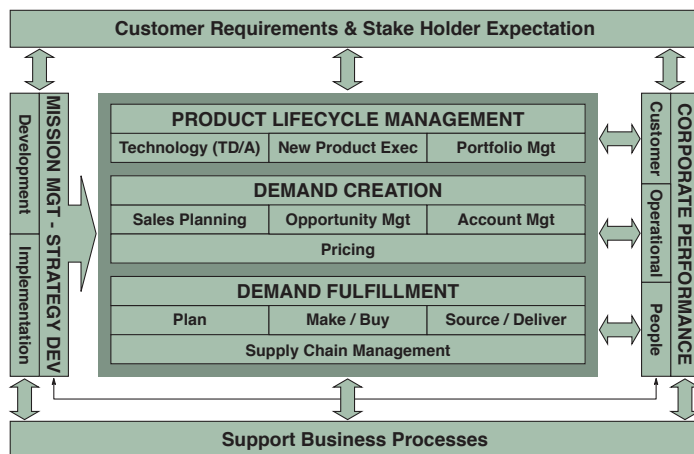

Our core business processes are linked to our global work processes ensuring alignment between our business strategy and practices.

ON Semiconductor Certification Status

Each of our manufacturing sites, support, marketing and design groups have been certified by Det Norske Veritas (DNV). Certificates are available at:

<http://www.onsemi.com/PowerSolutions/content.do?id=1156>

Six Sigma®

ON Semiconductor is committed to the Six Sigma philosophy in both our manufacturing and business environments.

Our Six Sigma efforts for the new millennium and beyond will be to:

- Continue our efforts to achieve Six Sigma results - and beyond - in everything we do (products and services)
- Measure in parts per billion (ppb)

Customer Satisfaction

ON Semiconductor is engaged in a very competitive global marketplace. We will not grow if we continue to focus only on our heritage and our past accomplishments. We continually strive to understand our customers' needs for service and support by focusing on customer service.

A key driver is the feedback we receive on the quality of our products and services. We strive to understand this so well that we will be able to anticipate solutions to product and service needs our customers have yet to recognize. This means listening to their ideas about how we can better serve them from a total system's perspective - from idea introduction to successful delivery of product or service.

How we gather this feedback? By asking how our external customers perceive ON Semiconductor in terms of quality and by asking them about their expectations of ON Semiconductor via deployment of the Annual Quality Survey. The objectives that will be accomplished through the Annual Quality Survey are:

- Continue strengthening our business operating system by determining our customers' current business expectations.
- Provide a baseline measurement of our performance against those expectations.
- Provide feedback on our performance against customer expectations on an annual basis (trends).
- Track changing expectations in order to modify our quality system accordingly.
- Provide a basis for a consistent set of customer satisfaction metrics that provides a check of our internal quality measurements.

Therefore, each business must develop customer driven indices - using factors established by the customer - and set aggressive improvement goals.

Our Goals will also change over time as customers raise the bar when we meet their current expectations.

ON Semiconductor Learning and Development

ON Semiconductor has instituted education and training that is directly linked to the strategic company goals identified by the Executive Council. All corporate driven training delivered is targeted toward those areas. To keep current with business needs, the training focus is reviewed annually in alignment with the corporate strategy. When the focus is determined, supporting training and education events are identified, designed, developed, and/or sourced to meet the need. This is a dynamic process with inputs from the organization, the employees and external market factors.

At the functional level, organizational capability is assessed, matched with current skills of the population, and gaps are filled accordingly. This job/skill match process allows alignment of business goals and job skill requirements.

The Lean Six Sigma Green and Black Belt training and SPC programs are examples of the many training programs developed by ON Semiconductor.

Section 3 – Introduction to Reliability & Quality Methods

For semiconductors, the often critical nature of the equipment in which they are used leaves no room for failure. By their very nature, properly designed semiconductor devices will far outlast the life expectancy of the equipment for which they are intended, and careful processing will ensure that each device meets the specifications to which it is designed.

The result of proper design and careful planning is a quality product.

The reliability and quality methods discussed in this handbook contribute to the attainment of Six Sigma performance in all of our operations.

Reliability Stress Tests

The following are brief descriptions of the tests commonly used in the reliability assessment. Not all of the tests listed are performed on each product. Other tests may be performed when appropriate. The information herein is typical of the testing performed. Variations to the following will be found throughout this document based on the limitations of the specific device being tested.

AUTOCLAVE

Autoclave is an environmental test which measures device resistance to moisture penetration and the resultant effects of galvanic corrosion. Autoclave is a highly accelerated and destructive test. Alternative test to Unbiased HAST.

Typical Test Conditions: $T_A = 121^\circ\text{C}$, $\text{rh} = 100\%$, $p = 1$ Atmosphere (15 psig), $t = 24$ to 240 hours.

Common Failure Modes: Parametric shifts, high leakage and/or catastrophic failure.

Common Failure Mechanisms: Die corrosion or contaminants such as foreign material on or within the package materials. Poor package sealing.

UNBIASED HIGHLY ACCELERATED STRESS TEST

Unbiased Highly Accelerated Stress is the same as HAST (below) with no bias. UHAST accelerates the same failure mechanisms as Autoclave.

Typical Test Conditions: $T_A = 130^\circ\text{C}$, $\text{rh} = 85\%$ to 95% , $p = 2$ Atmospheres, Bias = 80-100% of Data Book maximum rating, $T = 96$ to 240 hrs.

Common Failure Modes: Parametric shifts, high leakage and/or catastrophic failure.

Common Failure Mechanisms: Die corrosion or contaminants such as foreign material on or within the package materials. Poor package sealing.

HIGHLY ACCELERATED STRESS TEST

Highly Accelerated Stress Test uses a pressurized environment to produce extremely severe temperature, humidity and bias conditions. HAST accelerates the same failure mechanisms as High Humidity High Temperature Bias and Temperature Humidity Bias.

Typical Test Conditions: $T_A = 110$ - 130°C , $\text{rh} = 85\%$ to 95% , $p = 2$ Atmospheres, Bias = 80% to 100% of Data Book maximum rating, $t = 96$ to 246 hours.

Common Failure Modes: Parametric shifts, high leakage and/or catastrophic failure.

Common Failure Mechanisms: Die corrosion or contaminants such as foreign material on or within the package materials. Poor package sealing.

HIGH HUMIDITY HIGH TEMPERATURE BIAS/TEMPERATURE HUMIDITY BIAS

This is an environmental test designed to measure the moisture resistance of plastic encapsulated devices. A bias is applied to create an electrolytic cell necessary to accelerate corrosion of the die metallization. With time, this is a catastrophically destructive test. Alternative test to HAST.

Typical Test Conditions: $T_A = 85^\circ\text{C}$ to 95°C , $\text{rh} = 85\%$ to 95% , Bias = 80% to 100% of Data Book maximum rating, $t = 96$ to 1008 hours.

Common Failure Modes: Parametric shifts, high leakage and/or catastrophic failure.

Common Failure Mechanisms: Die corrosion or contaminants such as foreign material on or within the package materials. Poor package sealing.

HIGH TEMPERATURE GATE BIAS

This test is designed to electrically stress the gate oxide under a bias condition at high temperature.

Typical Test Conditions: $T_A = 150^\circ\text{C}$, Bias = 100% of Data Book maximum V_{gs} rating, $t = 168$ to 1008 hours.

Common Failure Modes: Parametric shifts in gate leakage and gate threshold voltage.

Common Failure Mechanisms: Random oxide defects and ionic contamination.

HIGH TEMPERATURE REVERSE BIAS /HIGH TEMPERATURE OPERATION LIFE

The purpose of these tests is to align mobile ions by means of temperature and voltage stress to form a high-current leakage path between two or more junctions.

Typical Test Conditions: $T_A = 85^\circ\text{C}$ to 175°C , Bias = 80% to 100% of Data Book maximum rating, $t = 168$ to 1008 hours.

Common Failure Modes: Parametric shifts in leakage and gain.

Common Failure Mechanisms: Ionic contamination on the surface or under the metallization of the die.

HIGH TEMPERATURE STORAGE LIFE

High temperature storage life testing is performed to accelerate failure mechanisms which are thermally activated through the application of extreme temperatures.

Typical Test Conditions: $T_A = 125^\circ\text{C}$ to 200°C , no bias, $t = 24$ to 1008 hours.

Common Failure Modes: Parametric shifts in leakage, V_f , V_{CEs} , R_{DSon} and gain.

Common Failure Mechanisms: Bulk die and diffusion defects.

INTERMITTENT OPERATING LIFE

The purpose of this test is to accelerate the stresses on all bonds and interfaces between the chip and mounting face of the device that simulates repeated turn on and off of equipment; checking the integrity of both wire and die bonds by means of thermal stressing.

Typical Test Conditions: $T_A = 25^\circ\text{C}$, Pd = Data Book maximum rating, $T_{on} = T_{off} = 2-5$ min (package dependent), DTJ of 125°C to 175°C , $t = 1000$ to 15000 cycles.

Common Failure Modes: Parametric shifts and catastrophic failure.

Common Failure Mechanisms: Foreign material, crack and bulk die defects, metallization, wire and diebond defects.

SOLDERABILITY

The purpose of this test is to measure the ability of device leads/terminals to be soldered after an extended period of storage or shelf life.

Typical Test Conditions: J-STD-002

Common Failure Modes: Pin holes, dewetting, non-wetting.

Common Failure Mechanisms: Poor plating, contaminated leads.

SOLDER HEAT

This test is used to measure the ability of a device to withstand the temperatures as may be seen in wave soldering operations. Electrical testing is the endpoint criterion for this stress.

Typical Test Conditions: Solder Temperature = 260°C , $t = 10$ seconds.

Common Failure Modes: Parameter shifts, mechanical failure.

TEMPERATURE CYCLING (AIR-TO-AIR)

The purpose of this test is to evaluate the ability of the device to withstand both exposure to extreme temperatures and transitions between temperature extremes. This testing will also expose excessive thermal mismatch between materials.

Typical Test Conditions: $T_A = -65^\circ\text{C}$ to 150°C , cycle = 100 to 1000.

Common Failure Modes: Parametric shifts and catastrophic failure.

Common Failure Mechanisms: Wire bond, cracked or lifted die and package failure.

Reliability Data Analysis

Reliability is the probability a semiconductor device will perform its specified function for a specified time period under specified environmental conditions. In general, reliability can be thought of as maintaining acceptable quality performance over time and environmental conditions. A key characteristic of reliability is the hazard rate $h(t)$. The hazard rate roughly represents the rate devices will fail as a function of time. The most widely used probability distribution used for analyzing semiconductor device reliability data is the exponential distribution. The hazard rate function for the exponential distribution λ (this is usually called the failure rate) is not a function of time and is very simple to estimate. The point estimate of the failure rate is obtained by dividing the number of observed failures by the total number of device-hours from the stress test. Device-hours are defined as the product of the number of devices that are stress tested and the duration of the stress test. This is called the point estimate because it is based on a sample of devices from the population of all devices with similar characteristics, and it does not account for the uncertainty caused by estimating the failure rate from a sample. For modern semiconductor devices, the failure rates are extremely low and the failure rate is presented in units of FIT, where FIT is the number of failures per billion device-hours. These calculations are appropriate when the exact failure times are known. More complicated censoring situations can be analyzed using techniques presented elsewhere (e.g., Meeker and Escobar, "Statistical Methods for Reliability Data," (1998)).

In order to account for the uncertainty due to calculating the failure rate based on a sample, one must apply confidence limits to the point estimate. The relevant confidence interval for device reliability calculations is the one-sided upper confidence interval of the failure rate. The one-sided upper confidence interval provides an estimate the failure rate that is unlikely to be exceeded by any given point estimate at a given confidence level. The appropriate sampling distribution for the failure rate of the exponential distribution is the chi-square distribution χ^2 . This means that if one were to calculate the failure rate of many independent samples drawn from the same exponential population, then the distribution of the point estimates of the failure rate would follow a χ^2 distribution. The one-sided upper confidence estimate of the exponential failure rate where the life test is time-censored is given by:

$$\lambda_{1\text{-sided}} = \frac{\chi^2(\alpha, 2r + 2)}{2nt} \cdot 10^9$$

where:

$\lambda_{1\text{-sided}}$ = one-sided upper confidence level failure rate estimate in FIT

χ^2 = the inverse cumulative distribution function for the chi-square distribution

$\alpha = (100 - \text{confidence level})/100$

r = number of failures observed during the stress test

n = number of devices in stress test sample

t = stress test duration in hours

Values of the inverse cumulative distribution function for the chi-square distribution for the 60% and 90% confidence levels are provided in Table 1.

Table 1. Chi-Square Inversion Cumulative Distribution Function

60% Confidence Level		90% Confidence Level	
No. Fails	χ^2 Quantity	No. Fails	χ^2 Quantity
0	1.833	0	4.605
1	4.045	1	7.779
2	6.211	2	10.645
3	8.351	3	13.362
4	10.473	4	15.987
5	12.584	5	18.549
6	14.685	6	21.064
7	16.780	7	23.542
8	18.868	8	25.989
9	20.951	9	28.412
10	23.031	10	30.813
11	25.106	11	33.196
12	27.179	12	35.563

Due to continuing process improvements and advances in device and package technologies, the failure rate of semiconductor devices is extremely low. To accurately assess the reliability of these devices, reliability engineers routinely use accelerated stress test conditions during reliability testing. These test conditions are carefully chosen to accelerate the failure mechanisms that are expected to occur under normal use conditions without introducing spurious failure mechanisms. Accelerated stress testing is used to provide estimates of device reliability performance under use conditions, and to assist in identifying opportunities for improving the reliability performance of the device. Failure mechanisms found during stress testing are traced to the root cause and eliminated, whenever possible.

The most commonly used stress accelerator is temperature. In most cases, elevated temperature increases the rate at which a given failure mechanism progresses. There are a few failure mechanisms that are accelerated by using lower temperatures. The simplest thermal acceleration model is the Arrhenius equation:

where:

$$\text{Rate} = A_0 e^{\frac{E_a}{KT}}$$

Rate = rate of progress for a given failure mechanism

A_0 = pre-exponential factor that is a characteristic of the given failure mechanism s^{-1}

E_a = Thermal activation energy of the failure mechanism in eV

k = Boltzman constant, $8.617 \cdot 10^{-5}$ eV/K

T = device junction temperature in degrees Kelvin

Using the Arrhenius equation, one can relate the failure rate at one stress condition to the failure rate at a different condition. The acceleration factor A_f is defined in the following manner:

$$A_f = \frac{\text{Rate (Condition 1)}}{\text{Rate (Condition 2)}}$$

where:

Rate (Condition 1) = rate of progress for a given failure mechanism at Condition 1 (i.e., T_1)

Rate (Condition 2) = rate of progress for a given failure mechanism at Condition 2 (i.e., T_2)

The thermal acceleration factor becomes:

$$A_f = e^{\frac{E_a}{k} \left(\frac{1}{T_1} - \frac{1}{T_2} \right)}$$

where:

T_1 and T_2 = device junction temperatures at stress conditions 1 and 2, respectively.

See Figure 1 for an example of how the acceleration factor is used to transform the stress testing time into the equivalent time at a typical use junction temperature.

ACTIVATION ENERGY

ON Semiconductor uses the industry-standard estimates for activation energies that are documented in JEDEC Publication JEP122, "Failure Mechanisms and Models for Silicon Semiconductor Devices." The following table summarizes the most commonly used activation energies.

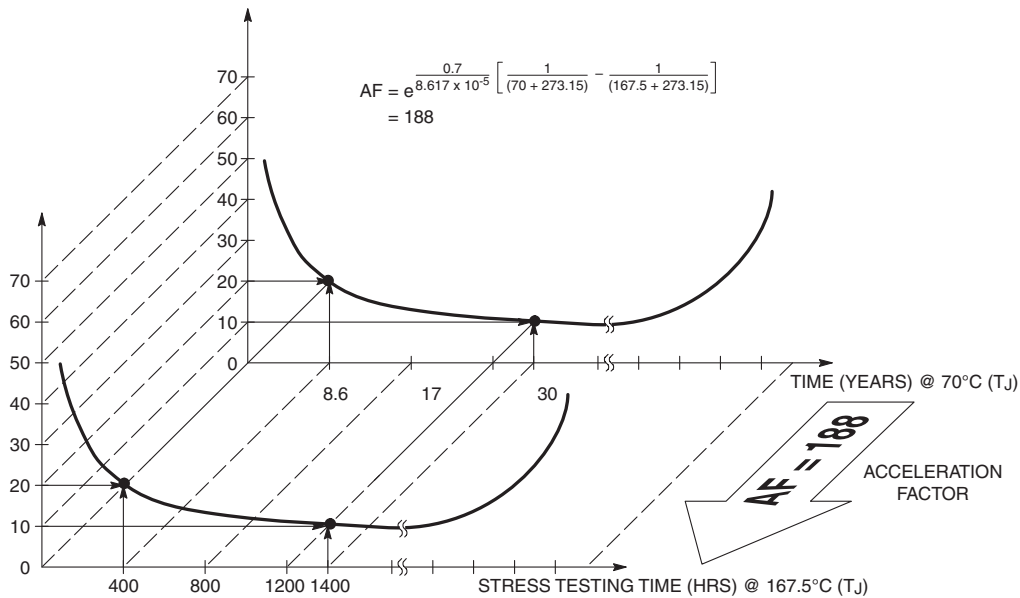

Figure 1. Example of Temperature Acceleration Factor
(0.7 eV Activation Energy)

Table 2. Activation Energy

Device Association	Failure Mechanism	Accelerating Failures	Typical Activation Energy (eV)
Silicon Surface Oxide	Surface Inversion	T, V	1.0
	Mobile Ions		1.0
	Charge Accumulation		1.0
	Surface Charge Spreading		0.7
Gate Oxide	Dielectric Breakdown	E, T	
	Thin Oxide (< 40 nm)		0.3
	Thick Oxide (≥ 40 nm)		0.7
Metallization	Electromigration	J, T	
	Pure Al		0.48
	AlSi (≤ 1.5%)		0.50
	AlSi (1.5%)		0.72
	AlCu (0.5%)		0.70
	AlCuSi (1% Si, 2% Cu)		0.70
	AlCu over TiW (>1% Cu)		0.71
	Corrosion	H, E/V, T, V	
	General		0.8
	With Chlorine		0.7
	With Phosphorus		0.53
Assembly Process	Intermetallics	T	
	Bromine-induced		1.0
	Halide-induced		0.5
	Chloride-induced		0.8
	Wire Bond	T, ΔT	0.75
Die Attach	T, ΔT	0.30	

T = Temperature, ΔT = Temperature Cycling, V = Voltage, E = Electric Field, J = Current Density, H = Humidity

THERMAL RESISTANCE

Circuit performance and long-term circuit reliability are affected by die temperature. Normally, both are improved by keeping the junction temperatures low.

Electrical power dissipated in any semiconductor device is a source of heat. This heat source increases the temperature of the die about some reference point, normally the ambient temperature of 25°C in still air. The temperature increase, then, depends on the amount of power dissipated in the circuit and on the net thermal resistance between the heat source and the reference point.

The temperature at the junction depends on the packaging and mounting system's ability to remove heat generated in the circuit from the junction region to the ambient environment. The basic formula for converting power dissipation to estimated junction temperature is:

$$T_J = T_A + P_D (\bar{\theta}_{JC} + \bar{\theta}_{CA})$$

or:

$$T_J = T_A + P_D (\bar{\theta}_{JA})$$

where:

T_J = maximum junction temperature

T_A = maximum ambient temperature

P_D = calculated maximum power dissipation, including effects of external loads when applicable

$\bar{\theta}_{JC}$ = average thermal resistance, junction-to-case

$\bar{\theta}_{CA}$ = average thermal resistance, case-to-ambient

$\bar{\theta}_{JA}$ = average thermal resistance, junction-to-ambient

Only two terms on the right side of equation (1) can be varied by the user, the ambient temperature and the device case-to-ambient thermal resistance, θ_{CA} . (To some extent, the device power dissipation can also be controlled, but under recommended use the supply voltage and loading dictate a fixed power dissipation.) Both system air flow and the package mounting technique affect the θ_{CA} thermal resistance term. θ_{JC} is essentially independent of air flow and external mounting method, but is sensitive to package material, die bonding method, and die area.

For applications where the case is held at essentially a fixed temperature by mounting on a large or temperature controlled heat sink, the estimated junction temperature is calculated by:

$$T_J = T_C + P_D (JC) (\bar{\theta}_{JC})$$

where T_C = maximum case temperature and the other parameters are as previously defined.

AIR FLOW

Air flow over the packages (due to a decrease in θ_{CA}) reduces the thermal resistance of the package, therefore, permitting a corresponding increase in power dissipation without exceeding the maximum permissible operating junction temperature. For thermal resistance values for specific packages, see the ON Semiconductor Data Book or Design Manual for the appropriate device family or contact your local ON Semiconductor sales office.

Section 4 – Customer Process Change Notification

ON Semiconductor is committed to delivering superior quality products to our valued customers and providing cost effective solutions. This commitment to continuous improvement in quality and value requires us to periodically make changes to our product portfolio. These changes are handled in accordance with ON Semiconductor’s change management system, described below, which is compliant to all international quality system standards such as ISO 9001, ISO/TS16949, AS-9100, Mil-PRF-38535, J-STD-046, J-STD-048, and mutually agreed Customer Specific Requirements.

Along with our commitment to quality and value, ON Semiconductor manages necessary product changes with a rigorous evaluation and characterization methodology to make them fully “transparent” to our valued customers from an electrical, physical, and thermal performance standpoint. Our goal is to make customer evaluation of any changed product unnecessary.

Change Management Overview

All proposed changes are classified in one of three classes, as determined by the nature and scope of the proposed change. The classification level indicates the level of qualification testing and customer notification required. The classification level is assigned by the corporate Business Change Action Board (BU CAB), which is an independent body chartered to represent the customer’s best interests with representatives from Quality & Reliability, the Business Units, Engineering and Manufacturing. Prior to submittal for Business Change Action Board review, the local manufacturing engineering reviews and approves any

potential changes first in the Manufacturing Change Action Board (Mfg CAB). This two-tiered requirement for review and approval is intended to provide thorough analysis of all changes for proper evaluation and risk mitigation.

Level 1 changes include any minor change to the materials, process method, process equipment or design, which has no effect on the visual appearance, external dimensions and tolerances, or performance of the finished product. Level 1 changes do not require reliability testing or customer notification, but do require product characterization prior to implementation.

Level 2 changes include any substantial change to the materials, process method, process equipment or design, which has no effect on the external dimensions and tolerances or performance of the finished product. Level 2 changes may have an effect on the visual appearance if the difference is purely cosmetic in nature and does not impact customer usage of the product. Level 2 changes require product characterization and reliability testing but do not require customer notification prior to implementation.

Level 3 changes include any substantial change to the materials, process method, process equipment or design, which do affect the visual appearance, external dimensions and tolerances, or performance of the finished product (also called ‘major changes’ in standard J-STD-046). Level 3 changes also include the transfer of existing wafer fabrication or assembly processes to a new manufacturing site. Level 3 changes require both product characterization and reliability testing, and are communicated to customers.

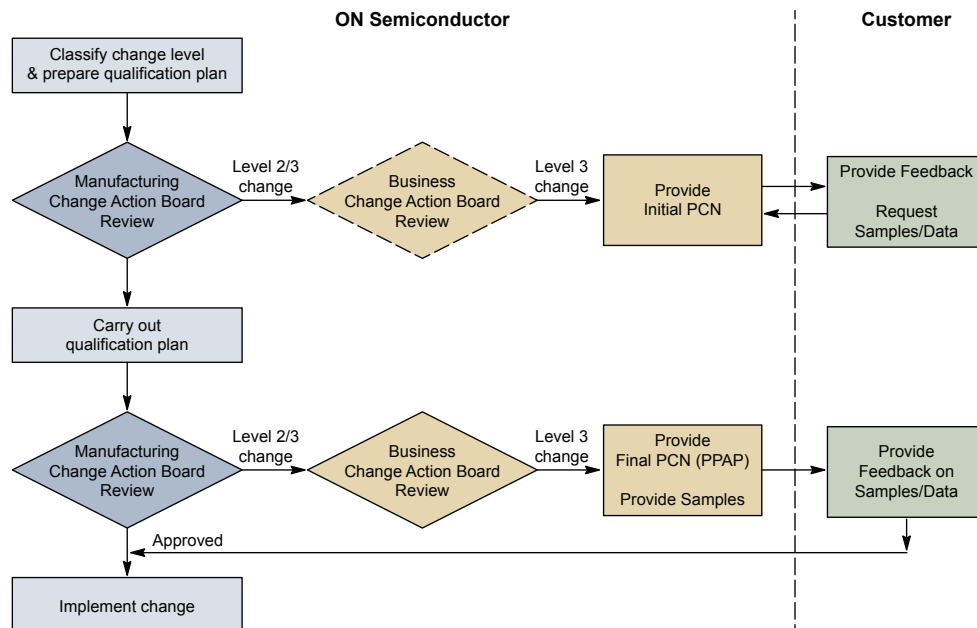

ON Semiconductor's Change Management Policy is to inform customers about Level 3 product and/or process changes in as many as three stages of communication.

Initial Product/Process Change Notification (IPCN) This "Initial Notification" is the first, formal notification distributed to customers. The IPCN is optional and gets typically distributed at least 30 days prior to the publication of the final PCN. The IPCN contains the qualification plan which must be completed prior to implementation, which gives our valued customers the opportunity to request any additional testing they might require in order to approve the change. The content of the qualification plan is dependent on the nature and scope of the change, but in all cases must be in compliance with applicable JEDEC and AEC standards.

Final Product/Process Change Notification (FPCN) This 'Final Notification' completes the notification process. The FPCN must be distributed at least 90 days prior to the effective date of the change, or can be implemented earlier when approved by the customer. The FPCN must contain successful results of all characterization and reliability testing documented in the qualification plan. Prior to issuance of the FPCN the characterization and reliability data is again reviewed and approved by both the

internal Manufacturing and Business Change Action Boards. The 90-day advance notification provides our valued customers with a final opportunity to communicate any additional requirements to accept the change prior to implementation if necessary. The PCN notification process and format is compliant to J-STD-046.

Product Discontinuance (PD) is a special type of Notification when the product/process goes to end-of-life. The Product Discontinuance is distributed to customers 6 months for a last purchase (Last Time Buy) and another 6 months for last shipments. The Product Discontinuance process is compliant to J-STD-0486.

Process Change Management System (PCMS) The customer will receive an email notification with hyperlink to the PCNAlert system for all the changes of the customer's affected part numbers. Customer should acknowledge receipt of the PCN within 30 days of delivery of the Notification. Acknowledgement is done by downloading the Notification document through the PCMS system. Lack of acknowledgement of the Notification within 30 days constitutes acceptance of the change. The generic notifications for standard products are additionally published on ON Semiconductor's external website (www.onsemi.com) and are accessible by everyone.

Section 5 – Supplier Quality Process

ON Semiconductor follows a five step Supplier Development process to improve the quality of goods and services delivered by our suppliers. The five steps of the process are: Planning, Implementation, Measurement, Improvement, and Recognition & Award.

During the Planning phase we establish general expectations of doing business with ON Semiconductor, and make our supplier selection based on their Quality System, Technical Capability, Value Added Services, Cost, Capacity, etc. Suppliers are requested to perform a Quality System self evaluation to VDA6.3 requirements.

Once a potential supplier has been selected they must pass our qualification process prior to making any production shipments; this is the Implementation step of our Supplier Development Process. In order to pass our qualification requirements suppliers must provide samples and data which demonstrates their product conforms to our specifications as well as their ability to manufacture the product consistently. This process will include

a review of First Article Inspection data, Process Control and Measurement System Analysis data, and an on-site audit by ON Semiconductor (for new suppliers). Any significant process changes made by the supplier go through the same qualification process described above, and are managed through our CAB process.

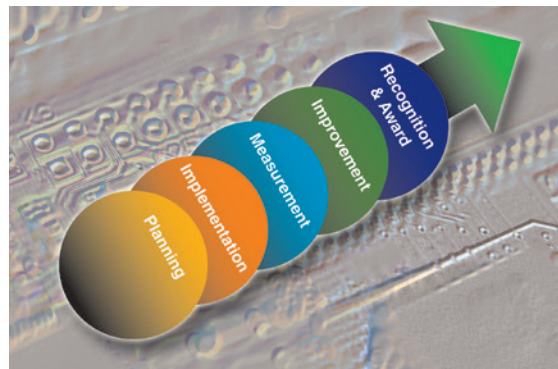

Once a supplier has been qualified we enter into the Measurement stage. The material we use in production is verified in one of three ways prior to use in production, the three methods are: Inspection, Audits combined with measurement of acceptable performance, and/or receipt & review of SPC data. If it is determined that material has been received that is non-conforming to our specified requirements we utilize our automated corrective action tracking system to ensure suppliers respond to the problem using an 8D corrective action. On a quarterly basis we measure our supplier's performance in the areas of Quality, Cost, Delivery, Service and Technology. This data is shared with our suppliers both by email as well as during Business Review Meetings. We also have an ongoing supplier assessment process (to VDA6.3 requirements) which is prioritized based on their certification status and ongoing performance as measured by our rating system.

Section 6 – Failure Analysis

Overview

Failure analysis is a process which entails vast analytical methods and techniques to solve the reliability and quality issues that may occur in either the manufacturing or application of our products. The process can be a rather complicated endeavor due to the many aspects associated with the ever advancing semiconductor and packaging technologies and the numerous engineering disciplines involved. The failure analyst must be proficient in design, process, assembly, test, and applications, which equates to electrical, physics, chemical, and mechanical engineering.

Failure analysis laboratories are available globally at all ON Semiconductor manufacturing sites. These same analytical tools are proactively utilized for good unit analysis, process characterization, destructive physical analysis, construction analysis, and even competitive benchmarking studies. Tool development for failure analysis is advancing at a similar rate as that of manufacturing. For the labs to stay current with technology, the analyst must be continually developing the associated tools and techniques. As the die features are shrinking and become covered with multiple layers of interconnects, the requirements for failure analysis needs to be anticipated as early as the design cycle. By incorporating these specialized test structures and functional test coverage, problems can more easily be diagnosed. In addition to tools, trained personnel, techniques, and procedures, an adequate database and tracking system should be employed to assist in expeditious problem solving.

At ON Semiconductor, the labs are equipped in a diverse range of instrumentation and engineering expertise to solve problems in all aspects of semiconductor and packaging analysis. The success

In the Improvement stage we establish goals with our suppliers using our Supplier Goal Plan (SGP) Process. This enables us to clearly define priorities for our suppliers, and provides us with a method to follow-up and verifies suppliers are meeting our goals. The SGP is reviewed with suppliers during Business Review meetings.

ON Semiconductor understands the value of recognizing and awarding suppliers for their hard work and dedication. We believe that by recognizing our best suppliers for their superb performance we are setting a standard for all our suppliers to achieve. This is the final step in our Supplier Development Process; Recognition and Award.

of failure analysis is not only in a superior instrumentation set, but in its people and their approach to problem solving. While the failure analysis lab may be able to identify a failure mechanism, the road to root cause is just embarked upon. Depending on the manufacturing process complexity, root cause analysis may entail extensive experimentation and designed experiments to not only identify the root cause but to also verify potential corrective action effectiveness. The full process of problem solving entails multiple labs and techniques. These analytical professionals along with the subject matter experts, such as design or manufacturing, work in unison to solve the problem.

Generic Process Steps

The full sequence of the problem solving events is outlined in Section 11, Customer Returns. The following steps outline the basic procedures that a typical field return may be subjected to within the failure analysis lab.

Required Information

The more information the better! There is a minimum set of background information that greatly impacts the overall quality and cycle time of the problem solving process. The minimum set and some questions are as follows:

1. Failure history and failure rate at the customer site, in either this application or other products. Is this a new product or have any changes occurred in this time frame?
2. Length of time in application and the conditions upon failure should be included. Did any other components fail at the same time and if so, how did they fail? Can a schematic be sent? Are there any devices of this same date code still available?

3. What is the failure mode of the application and how can it be related to this device? How do you perceive that the device is failing (short, open, stuck logic levels, etc.)?
4. How was the device handled prior to receipt at ON Semiconductor? Precautions should be taken in the removal and handling (ESD) of the devices to insure that electrical or physical damage does not occur and testability of the package is maintained.

Receipt of Request

When the product is received in the failure analysis lab, the devices have generally been confirmed as failures through the use of automatic test equipment to achieve rapid failure verification by our customer support group. At this point, the background documentation, electrical results and historical failure data are reviewed to outline the appropriate course of analytical action. An external visual inspection is carried out, documenting the package's physical condition and markings.

Diagnostic Testing

The devices would most likely be subjected to a benign "pin-to-pin" test which quickly identifies parametric anomalies as compared to known good units. Depending on the failure mode, the device may be subjected to a more extensive bench test with stress conditions applied to match the customer's application or to stimulate the mechanism.

Non-destructive Testing

Failure analysis in itself is reverse engineering and in this vein, destructive in nature to the returned product. Since the package will be at least partially destroyed to expose the die, non-destructive techniques are carried out first to observe package or assembly related mechanisms. The most common techniques used are acoustic microscopy and radiographic (XRAY) inspections to look for internal assembly or molding anomalies.

Storage Bakes or Stress

Depending on the failure mode, the analyst may subject the device to a series of vacuum or storage bakes to observe parametric or functional shifts. If the original failure mode was not confirmed, stress testing (high temperature bias for instance), may be carried out to observe possible longer-term reliability concerns.

Decapsulation or Package Preparation

The general course of action at this point is to reveal the die surface. In the case of a plastic encapsulated component, this would entail a chemical decapsulation. There are however, many methods utilized for decapsulation or package preparation, dependent on the package, failure mode, and potential failure mechanism.

Internal Inspection

An internal optical inspection would then be carried out to check for any obvious assembly anomalies or wafer fabrication issues. If possible re-testing is recommended at this point to insure that the failure mode has not changed.

Internal Diagnostic Testing

In many cases, the internal inspection will not reveal an obvious failure mechanism. At this point, depending on the technology and level of testability, the lab would utilize one or more of the techniques available to isolate the failure site. This could entail extensive probing or a technique, such as liquid crystal or photoemission, to highlight potential anomalies. The majority of these techniques are attempting to observe the properties of the failure site, as in thermal dissipation or photon emission. From a probing standpoint, the use of navigational tools, a laser cutter or Focused Ion Beam (FIB) may be employed to assist in device and circuit isolation.

Deprocessing

Deprocessing is an iterative process of removing layer of the die, which may entail both wet chemistry and dry plasma etching techniques to reveal the underlying structures. The proper techniques are critical at these steps due to the destructive nature of the process and the potential loss of vital information.

Analysis of Failure Site

Once a potential site has been determined or revealed, further documentation and analysis may be conducted. Further analytical techniques are employed depending on whether the morphology or material composition is required.

Report Conclusion

Upon completion of the analysis, a written report is generated documenting the work. The report should state the relationship of the physical anomaly to the failure mode. It should also include sufficient documentation for root cause analysis by the manufacturing site if warranted.

Summary

The cost of failure analysis is high due to the extensive instrumentation, highly technical staff, continual training and development, and associated analysis expenses (chemicals, fixtures, etc.). To enable the most efficient utilization of these resources, it is essential that the background documentation (see Required Information on the previous page) be complete upon receipt and that an open communication channel between ON Semiconductor and our customers exists. This will insure a timely resolution of the problem on either end.

Section 7 – Reliability Data Summary

ON Semiconductor performs extensive reliability stress testing on devices that span the full breadth of our product portfolio. Reliability data is collected as part of the ON Semiconductor Reliability Audit Program, and as part of the normal product qualification and re-qualification process. This data is periodically updated to include the most recent test results. The data is typically updated on a quarterly basis. The current data can always be located through the reliability data links on the ON Semiconductor website.

<http://www.onsemi.com/PowerSolutions/reliability.do>

The reliability data is presented in two parts:

1. Life Test Data that groups the data by business unit and product family or technology. This data provides information that pertains primarily to die design- and wafer fabrication-related failure mechanisms.
2. Package Test Data that groups the data by package case outline and product family or technology. This data provides information that pertains primarily to package design- and assembly process-related failure mechanisms.

The ON Semiconductor package outline reference is also included to make it easier to identify a specific case outline.

Section 8 – External Manufacturing Quality

ON Semiconductor utilizes packaging and testing subcontractor, foundry or external wafer fabrication manufacturer and joint venture partners to support our customers' increasing requirements for high quality, low cost semiconductors. Our global subcontractor, foundry and joint venture partners perform some or all areas of semiconductor manufacturing. This includes wafer fabrication, wafer probe, assembly, test, as well as product analysis, and reliability testing. When ON Semiconductor selects new manufacturing subcontractors and foundries, this requires an extensive review of the company's ability to meet our high quality, business and technical requirements. For current manufacturing partners, continuous improvement plans are required which outline aggressive improvement goals. Progress to these goals is periodically reviewed.

The new product introduction and process change control requirements and specifications are the same for internal

ON Semiconductor factories as well as our external manufacturing partners. Quality systems vary from subcontractor to subcontractor and foundry to foundry; however,

ON Semiconductor requires each supplier to manufacture our products with the same high standards as our internal factories. Prior to engaging with a subcontractor as a new supplier or when adding a new or expanded manufacturing line, ON Semiconductor performs an extensive assessment. This includes a review of the machine capability and maintenance, process documentation and control, training and certification of personnel, FMEA's, as well as many other areas. Detailed project management methodology is utilized to drive projects to a timely completion.

ON Semiconductor encourages each subcontractor and foundry to pursue outside certification to drive their quality system improvements.

Additionally, we drive many of our internal factories quality system practices into our external partners. Periodic subcontractor and foundry reviews are held to review progress to key metrics including customer quality and delivery. Joint corrective action plans are agreed upon to drive resolution and continuous improvements.

Section 9 – Customer Returns

ON Semiconductor's Global Customer Return or Incident process is focused on formal Problem Solving and Responsiveness. We use the 8D Problem Solving Methodology to determine Containment, Root Cause, and Corrective/Preventive Actions.

The Eight Disciplines are:

D1 - Establish the Team - Establish a cross functional team of people with the process/product knowledge to solve the problem.

D2 - Describe the Problem - Specify the customer's problem by identifying in quantifiable terms the who, what, where, why, how, and how many, for the problem.

D3 - Implement and Verify Containment - Define and Implement containment actions to isolate the effect of the problem from customers until the corrective actions are implemented.

D4 - Define and Verify Root Cause - Identify all potential causes that could explain why the problem occurred and how it escaped

our testing. Isolate and verify root cause by testing each potential cause against the problem description.

D5 - Choose and Verify Permanent Corrective Action - Identify all potential corrective actions for the Occur and Escape Root Causes. Verify which actions will correct the root cause.

D6 - Implement Permanent Corrective Action - Provide action plans for implementation of the verified corrective actions. Follow up on any outstanding actions.

D7 - Prevent Recurrence - Implement actions to address the "system" failure. Update control plans, FMEA specifications, process specifications. Fan-Out Corrective Actions to appropriate manufacturing sites, and other Technologies.

D8 - Congratulate the Team - We communicate to the customer throughout the process.

Customer Incident Process Map

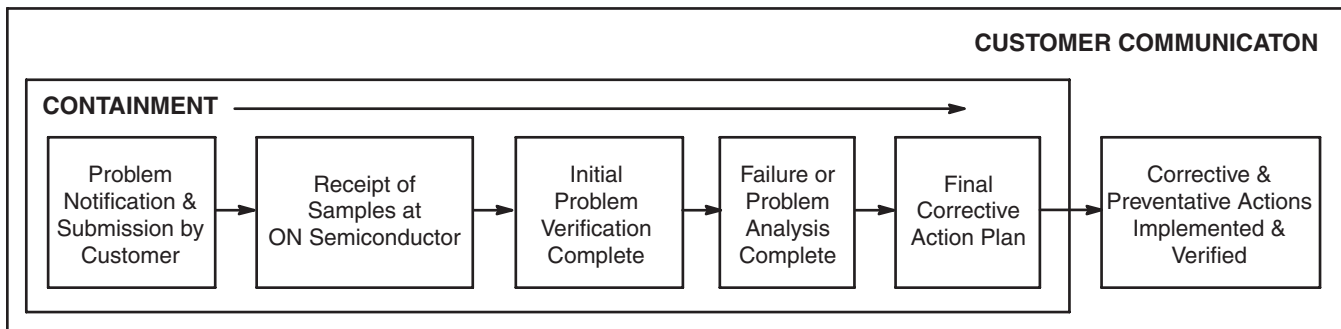

Customer Incidents are tracked in our Customer Incident information system. Monthly customer incident metrics are compiled and distributed corporate-wide. Responsiveness metrics are used to drive continuous improvement in the Cycle Time arena. Failure Mechanism paretos are used to drive continuous improvement in the Product and Administrative Quality arenas. These metrics are also reviewed in our monthly Business Unit & Manufacturing Operations Reviews

Section 10 – New Product Development

ON Semiconductor is using a phase/gate approach (aka Advanced Product Quality Planning - APQP) for New Product Development, as shown in figure below. The major project milestones and phase-gates provide points where the project undergoes a formal review of all deliverables required for that phase. The following design and development phases (gates) are determined for the NPD process:

- Concept (Concept Commit gate),
- Plan (Plan Commit gate),
- Develop (Develop Complete gate),
- Qualify (Qualify Complete gate),
- Launch (Launch Complete gate).

The Sustain and Retire are phases of the Product Life Cycle, but extend beyond, and are not part of NPD.

The **Concept Phase** is the starting point for new product ideas (proposals), and their associated business opportunity. The primary activity that occurs during the Concept Phase is the analysis of the NPD opportunity from both a technical feasibility and a business viability point of view.

The **Plan Phase** validates the assumptions made during Concept Phase on scope, schedule and cost. Identified discrepancies with customer expectations must be resolved by the end of this phase. This phase includes the creation of the Project Plan, the Verification and Validation (Qualification) plans, and the Product Technical Specification. For automotive projects, a Design Failure-Mode-Effects-Analysis (DFMEA) is being initiated in accordance to

the AIAG standard to identify, document, assess, and manage the project risks. Additionally for automotive, the Production Part Approval Process (PPAP) level is determined.

The **Develop Phase** encapsulates the execution of the main design and development activities for the new product in accordance with the product requirements and the project plan. This may include silicon design, layout, test, hardware or software design and development, or package development as identified in the Project Plan. Design and development verification and validations are being performed in accordance with planned arrangements to ensure that the design and development outputs meet the design and development input requirements.

During the **Qualify phase**, the design and development validation gets completed, including Reliability tests (see section 3), product approval, and ensuring product readiness for Manufacturing, Supply Chain, Sales and Marketing. For automotive products, this is the phase where the PPAP is completed.

The purpose of the **Launch Phase** is to demonstrate that the product can be delivered in high volume with conditions that are acceptable for both ON Semiconductor (cost, manufacturability) and the customer (quality/reliability, volume).

The Product Discontinuance takes place in the **Retire Phase** of the product life cycle. This is controlled by the Product Discontinuance notice as described in section ‘Customer Process Change Notification’.

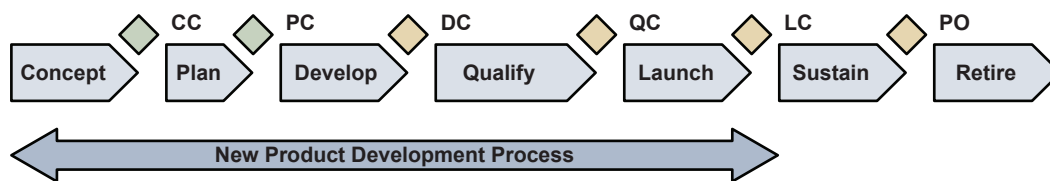

Section 11 – ISO 26262 Automotive Functional Safety

A dedicated organization has been defined to enhance the safety culture within the company and to integrate the ISO 26262 requirements in our existing development flow. Refer to diagram below. Those requirements supplement our current Quality Management System that is based on ISO 9001 and ISO/TS 16949.

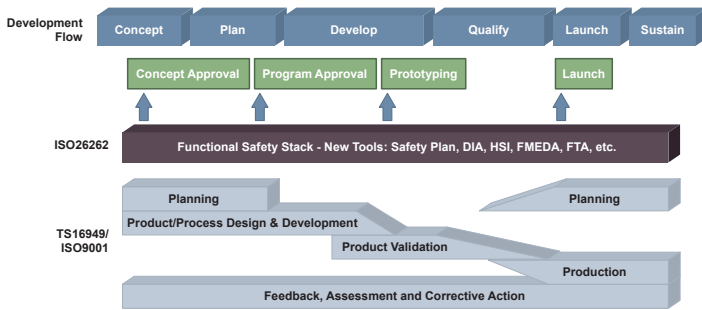

ISO 26262 is an adaptation of IEC 61508 for the automotive industry. The first edition of the standard was released in November 2011. Since then, ISO 26262 has become the state of the art and is now widely used in the development of automotive safety related integrated circuits.

ISO 26262 is focused on the Functional Safety (absence of unreasonable risk) in passenger vehicles and addresses possible hazards caused by the malfunctioning behavior of electrical and/

or electronic (E/E) systems installed in those vehicles. This means that the standard is not only applicable to the system itself, but also to the elements that are composing the system. The elements are characterized by their Automotive Safety Integrated Level (ASIL). ASIL levels range from A to D, with ASIL D being the most stringent.

ISO 26262 includes 10 parts and approximately 750 clauses dealing with each part of the product lifecycle, from project management, to product development, through production, and ending with decommissioning. Not all of the requirements from the standard are applicable to the development of integrated circuits, as some of them only focus on the system level development and on safety analysis (see diagram below).

The main requirements brought by ISO 26262 compared to the regular QMS are defined in Part 5 (Product Development Hardware), Part 8 (Supporting Processes) and Part 9 (ASIL oriented and safety-oriented analysis). They describe the hardware product development flow as well as the tools that are needed to develop safe products. These requirements are, for example, related to the specification of the hardware safety requirements, the definition of the safety mechanisms, and the execution of the safety analysis (e.g. Failure Modes Effects and Diagnostic Analysis (MEDA), Fault Tree Analysis (FTA)).

ON Semiconductor is an active member of the ISO 26262 task force and part of the semiconductor sub-workgroup.

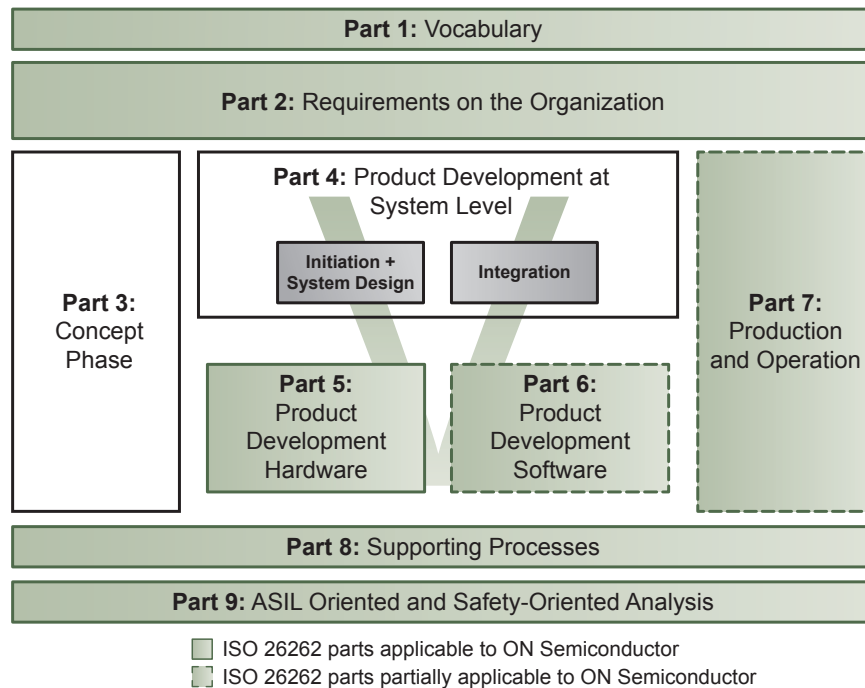

Section 12 – Storage and Preservation

ON Semiconductor adheres in the proper storage and preservation of semiconductors in order to prevent damage or deterioration and ensure on-time delivery of superior quality products to our valued customers. The standard storage and preservation guidelines are tabulated below and followed by all

ON Semiconductor manufacturing sites including subcontractors and distribution centers.

The storage durations are monitored in our Supply Chain and Finance information systems. These are tracked on a monthly basis to drive on-time delivery.

Table 3. Storage and Preservation*

ON Semiconductor Product	Storage Condition	Storage Life
Finished Wafer, Probe Wafer	Temperature 18-28°C Humidity 30-65% RH	36 months after final wafer fab finish date
Die in Tray or Pocket Tape	Temperature 18-28°C, Humidity 30-65% RH	24 months after die singulation/sawing date
Die in Surf Tape, Wafers in Foil/Tape	Temperature 18-28°C, N2 storage or in vacuum moisture bag with desiccant and humidity card	3 months after tape date After 3 months quality of products needs to be validated
Finished/ Packaged Goods in tray, Tube or sealed in dry bag (MSL2 rated and above)	Temperature 8-30°C Humidity 30-70% RH	24 months after assembly date
Finished/packaged Goods in Tray, Tube or sealed in dry bag (MSL1 rated)	Temperature 8-30°C Humidity 30-70% RH	24 months after assembly date
Finished/Packaged Ceramics in Tray or Tube	Temperature 8-30°C Humidity 30-70% RH	36 months after assembly date

* Regular temperature monitor is needed to ensure no sudden changes in temperature that can result to moisture condensation during storage.

Section 13 – ON Semiconductor Corporate Social Responsibility and Sustainability

Corporate Social Responsibility Statement of Commitment

As a global supplier to customers worldwide, ON Semiconductor operates across a diverse range of cultures and international markets. We are committed to providing our customers with inventive, high quality products that are environmentally sound, conducting our operations in an environmentally, socially and ethically responsible manner and complying with all applicable laws and regulations of those countries worldwide where we do business. This commitment is deeply ingrained in our Core Values, certain policies and our Code of Business Conduct (“Code”).

ON Semiconductor belongs to a number of organizations and initiatives focused on technological advances in sustainable energy, power conservation and corporate responsibility. One of these is the Electronic Industry Citizenship Coalition (EICC). As a full member of the EICC, we embrace the EICC Code of Conduct and have incorporated these tenets into our facility and supplier programs. Additionally we work collaboratively with our suppliers to encourage their compliance with the EICC’s conflict-

free mineral policy and other supply chain Initiatives.

ON Semiconductor is proud of our commitment to operate in a socially responsible manner towards our employees, suppliers, customers and the communities in which we do business worldwide.

Labor, Environmental, Health & Safety and Ethics Standards

A. Labor

We are committed to uphold the human rights of workers, and to treat them with dignity and respect as understood by the international community. This applies to all workers including temporary, migrant, student, contract, direct employees, and any other type of worker.

The labor standards are:

- 1) **Freely Chosen Employment** – Forced, bonded (including debt bondage) or indentured labor, involuntary prison labor, slavery or trafficking of persons shall not be used. This includes transporting, harboring, recruiting,

transferring or receiving persons by means of threat, force, coercion, abduction or fraud for labor or services. There shall be no unreasonable restrictions on workers' freedom of movement in the facility in addition to unreasonable restrictions on entering or exiting company-provided facilities. As part of the hiring process, workers must be provided with a written employment agreement in their native language that contains a description of terms and conditions of employment prior to the worker departing from his or her country of origin. All work must be voluntary and workers shall be free to leave work at any time or terminate their employment. Employers and agents may not hold or otherwise destroy, conceal, confiscate or deny access by employees to their identity or immigration documents, such as government-issued identification, passports or work permits, unless such holdings are required by law. Workers shall not be required to pay employers' or agents' recruitment fees or other related fees for their employment. If any such fees are found to have been paid by workers, such fees shall be repaid to the worker.

- 2) **Young Workers** – Child labor is not to be used in any stage of manufacturing. The term “child” refers to any person under the age of 15, or under the age for completing compulsory education, or under the minimum age for employment in the country, whichever is greatest. The use of legitimate workplace learning programs, which comply with all laws and regulations, is supported. Workers under the age of 18 (Young Workers) shall not perform work that is likely to jeopardize their health or safety, including night shifts and overtime. Participant shall ensure proper management of student workers through proper maintenance of student records, rigorous due diligence of educational partners, and protection of students' rights in accordance with applicable law and regulations. Participant shall provide appropriate support and training to all student workers. In the absence of local law, the wage rate for student workers, interns and apprentices shall be at least the same wage rate as other entry-level workers performing equal or similar tasks.
- 3) **Working Hours** – Studies of business practices clearly link worker strain to reduced productivity, increased turnover and increased injury and illness. Workweeks are not to exceed the maximum set by local law. Further, a workweek should not be more than 60 hours per week, including overtime, except in emergency or unusual situations. Workers shall be allowed at least one day off every seven days.

- 4) **Wages and Benefits** – Compensation paid to workers shall comply with all applicable wage laws, including those relating to minimum wages, overtime hours and legally mandated benefits. In compliance with local laws, workers shall be compensated for overtime at pay rates greater than regular hourly rates. Deductions from wages as a disciplinary measure shall not be permitted. For each pay period, workers shall be provided with a timely and understandable wage statement that includes sufficient information to verify accurate compensation for work performed. All use of temporary, dispatch and outsourced labor will be within the limits of the local law.
- 5) **Humane Treatment** – There is to be no harsh and inhumane treatment including any sexual harassment, sexual abuse, corporal punishment, mental or physical coercion or verbal abuse of workers; nor is there to be the threat of any such treatment. Disciplinary policies and procedures in support of these requirements shall be clearly defined and communicated to workers.
- 6) **Non-Discrimination** – Participants should be committed to a workforce free of harassment and unlawful discrimination. Companies shall not engage in discrimination based on race, color, age, gender, sexual orientation, gender identity and expression, ethnicity or national origin, disability, pregnancy, religion, political affiliation, union membership, covered veteran status, protected genetic information or marital status in hiring and employment practices such as wages, promotions, rewards, and access to training. Workers shall be provided with reasonable accommodation for religious practices. In addition, workers or potential workers should not be subjected to medical tests or physical exams that could be used in a discriminatory way.
- 7) **Freedom of Association** – In conformance with local law, participants shall respect the right of all workers to form and join trade unions of their own choosing, to bargain collectively and to engage in peaceful assembly as well as respect the right of workers to refrain from such activities. Workers and/or their representatives shall be able to openly communicate and share ideas and concerns with management regarding working conditions and management practices without fear of discrimination, reprisal, intimidation or harassment.

B. Health and Safety Standards

We recognize that in addition to minimizing the incidence of work-related injury and illness, a safe and healthy work environment enhances the quality of products and services, consistency of production and worker retention and morale.

We also recognize that ongoing worker input and education is essential to identifying and solving health and safety issues in the workplace.

- 1) **Occupational Safety** – Worker exposure to potential safety hazards (e.g., electrical and other energy sources, fire, vehicles, and fall hazards) are to be controlled through proper design, engineering and administrative controls, preventative maintenance and safe work procedures (including lockout/tagout), and ongoing safety training. Where hazards cannot be adequately controlled by these means, workers are to be provided with appropriate, well-maintained, personal protective equipment and educational materials about risks to them associated with these hazards. Workers shall be encouraged to raise safety concerns.
- 2) **Emergency Preparedness** – Potential emergency situations and events are to be identified and assessed, and their impact minimized by implementing emergency plans and response procedures including: emergency reporting, employee notification and evacuation procedures, worker training and drills, appropriate fire detection and suppression equipment, adequate exit facilities and recovery plans. Such plans and procedures shall focus on minimizing harm to life, the environment and property.
- 3) **Occupational Injury and Illness** – Procedures and systems are to be in place to prevent, manage, track and report occupational injury and illness including provisions to: encourage worker reporting; classify and record injury and illness cases; provide necessary medical treatment; investigate cases and implement corrective actions to eliminate their causes; and facilitate return of workers to work.
- 4) **Industrial Hygiene** – Worker exposure to chemical, biological and physical agents is to be identified, evaluated, and controlled. Engineering or administrative controls must be used to control overexposures. When hazards cannot be adequately controlled by such means, worker health is to be protected by appropriate personal protective equipment programs.
- 5) **Physically Demanding Work** – Worker exposure to the hazards of physically demanding tasks, including manual material handling and heavy or repetitive lifting, prolonged standing and highly repetitive or forceful assembly tasks is to be identified, evaluated and controlled.
- 6) **Machine Safeguarding** – Production and other machinery shall be evaluated for safety hazards. Physical guards, interlocks and barriers are to be provided and properly maintained where machinery presents an injury hazard to workers.

- 7) **Sanitation, Food, and Housing** – Workers are to be provided with ready access to clean toilet facilities, potable water and sanitary food preparation, storage, and eating facilities. Worker dormitories provided by the Participant or a labor agent are to be maintained to be clean and safe, and provided with appropriate emergency egress, hot water for bathing and showering, adequate heat and ventilation, and reasonable personal space along with reasonable entry and exit privileges.
- 8) **Health and Safety Communication** – Participant shall provide workers with appropriate workplace health and safety training in their primary language. Health and safety related information shall be clearly posted in the facility.

C. Environmental

We recognize that environmental responsibility is integral to producing world class products. In manufacturing operations, adverse effects on the community, environment and natural resources are to be minimized while safeguarding the health and safety of the public.

The environmental standards are:

- 1) **Environmental Permits and Reporting** – All required environmental permits (e.g. discharge monitoring), approvals and registrations are to be obtained, maintained and kept current and their operational and reporting requirements are to be followed.
- 2) **Pollution Prevention and Resource Reduction** – The use of resources and generation of waste of all types, including water and energy, are to be reduced or eliminated at the source or by practices such as modifying production, maintenance and facility processes, materials substitution, conservation, recycling and re-using materials.
- 3) **Hazardous Substances** – Chemicals and other materials posing a hazard if released to the environment are to be identified and managed to ensure their safe handling, movement, storage, use, recycling or reuse and disposal.
- 4) **Wastewater and Solid Waste** – Participant shall implement a systematic approach to identify, manage, reduce, and responsibly dispose of or recycle solid waste (non-hazardous). Wastewater generated from operations, industrial processes and sanitation facilities are to be characterized, monitored, controlled and treated as required prior to discharge or disposal. In addition, measures should be implemented to reduce generation of wastewater. Participant shall conduct routine monitoring of the performance of its wastewater treatment systems.
- 5) **Air Emissions** – Air emissions of volatile organic chemicals, aerosols, corrosives, particulates, ozone

depleting chemicals and combustion by-products generated from operations are to be characterized, routinely monitored, controlled and treated as required prior to discharge. Participant shall conduct routine monitoring of the performance of its air emission control systems.

- 6) **Materials Restrictions** – Participants are to adhere to all applicable laws, regulations and customer requirements regarding prohibition or restriction of specific substances in products and manufacturing, including labeling for recycling and disposal.
- 7) **Storm Water Management** – Participant shall implement a systematic approach to prevent contamination of storm water runoff. Participant shall prevent illegal discharges and spills from entering storm drains.
- 8) **Energy Consumption & Greenhouse Gas Emissions** – Energy consumption and greenhouse gas emissions are to be tracked and documented, at the facility and/or corporate level. Participants are to look for cost-effective methods to improve energy efficiency and to minimize their energy consumption and greenhouse gas emissions.

D. Ethics

To meet social responsibilities and to achieve success in the marketplace, We will uphold the highest standards of ethics including:

- 1) **Business Integrity** – The highest standards of integrity are to be upheld in all business interactions. Participants shall have a zero tolerance policy to prohibit any and all forms of bribery, corruption, extortion and embezzlement. All business dealings should be transparently performed and accurately reflected on Participant's business books and records. Monitoring and enforcement procedures shall be implemented to ensure compliance with anti-corruption laws.
- 2) **No Improper Advantage** – Bribes or other means of obtaining undue or improper advantage are not to be promised, offered, authorized, given or accepted. This prohibition covers promising, offering, authorizing, giving or accepting anything of value, either directly or indirectly through a third party, in order to obtain or retain business, direct business to any person, or otherwise gain an improper advantage.
- 3) **Disclosure of Information** – Information regarding participant labor, health and safety, environmental practices, business activities, structure, financial situation and performance is to be disclosed in accordance with applicable regulations and prevailing industry practices.

Falsification of records or misrepresentation of conditions or practices in the supply chain are unacceptable.

- 4) **Intellectual Property** – Intellectual property rights are to be respected; transfer of technology and know-how is to be done in a manner that protects intellectual property rights; and, customer information is to be safeguarded.
- 5) **Fair Business, Advertising and Competition** – Standards of fair business, advertising and competition are to be upheld. Appropriate means to safeguard customer information must be available.
- 6) **Protection of Identity and Non-Retaliation** – Programs that ensure the confidentiality, anonymity and protection of supplier and employee whistleblowers² are to be maintained, unless prohibited by law. Participants should have a communicated process for their personnel to be able to raise any concerns without fear of retaliation.
- 7) **Responsible Sourcing of Minerals** – Participants shall have a policy to reasonably assure that the tantalum, tin, tungsten and gold in the products they manufacture does not directly or indirectly finance or benefit armed groups that are perpetrators of serious human rights abuses in the Democratic Republic of the Congo or an adjoining country. Participants shall exercise due diligence on the source and chain of custody of these minerals and make their due diligence measures available to customers upon customer request.
- 8) **Privacy** – Participants are to commit to protecting the reasonable privacy expectations of personal information of everyone they do business with, including suppliers, customers, consumers and employees. Participants are to comply with privacy and information security laws and regulatory requirements when personal information is collected, stored, processed, transmitted, and shared.

E. Management Systems

We adopt or establish a management system whose scope is related to the content of this Code. The management system shall be designed to ensure: (a) compliance with applicable laws, regulations and customer requirements related to the operations and products; (b) conformance with EICC Code; and (c) identification and mitigation of operational risks related to EICC Code. It also facilitates continual improvement.

Our CSR management system contains the following elements:

- 1) **Company Commitment** – A corporate social and environmental responsibility policy statements affirming Participant's commitment to compliance and continual improvement, endorsed by executive management and posted in the facility in the local language.

- 2) **Management Accountability and Responsibility** – The Participant clearly identifies senior executive and company representative[s] responsible for ensuring implementation of the management systems and associated programs. Senior management reviews the status of the management system on a regular basis.
- 3) **Legal and Customer Requirements** – A process to identify, monitor and understand applicable laws, regulations and customer requirements, including the requirements of this Code.
- 4) **Risk Assessment and Risk Management** – A process to identify the legal compliance, environmental, health and safety³ and labor practice and ethics risks associated with Participant’s operations. Determination of the relative significance for each risk and implementation of appropriate procedural and physical controls to control the identified risks and ensure regulatory compliance.
- 5) **Improvement Objectives** – Written performance objectives, targets and implementation plans to improve the Participant’s social and environmental performance, including a periodic assessment of Participant’s performance in achieving those objectives.
- 6) **Training** – Programs for training managers and workers to implement Participant’s policies, procedures and improvement objectives and to meet applicable legal and regulatory requirements.
- 7) **Communication** – A process for communicating clear and accurate information about Participant’s policies, practices, expectations and performance to workers, suppliers and customers.
- 8) **Worker Feedback and Participation** – Ongoing processes to assess employees’ understanding of and obtain feedback on practices and conditions covered by this Code and to foster continuous improvement.
- 9) **Audits and Assessments** – Periodic self-evaluations to ensure conformity to legal and regulatory requirements, the content of the Code and customer contractual requirements related to social and environmental responsibility.
- 10) **Corrective Action Process** – A process for timely correction of deficiencies identified by internal or external assessments, inspections, investigations and reviews.
- 11) **Documentation and Records** – Creation and maintenance of documents and records to ensure regulatory compliance and conformity to company requirements along with appropriate confidentiality to protect privacy.
- 12) **Supplier Responsibility** – A process to communicate Code requirements to suppliers and to monitor supplier compliance to the Code.

Six Sigma is a registered trademark of Motorola, Inc.

ON Semiconductor and the ON Semiconductor logo are trademarks of Semiconductor Components Industries, LLC dba ON Semiconductor or its subsidiaries in the United States and/or other countries. ON Semiconductor owns the rights to a number of patents, trademarks, copyrights, trade secrets, and other intellectual property. A listing of ON Semiconductor’s product/patent coverage may be accessed at www.onsemi.com/site/pdf/Patent-Marking.pdf. ON Semiconductor reserves the right to make changes without further notice to any products herein. ON Semiconductor makes no warranty, representation or guarantee regarding the suitability of its products for any particular purpose, nor does ON Semiconductor assume any liability arising out of the application or use of any product or circuit, and specifically disclaims any and all liability, including without limitation special, consequential or incidental damages. Buyer is responsible for its products and applications using ON Semiconductor products, including compliance with all laws, regulations and safety requirements or standards, regardless of any support or applications information provided by ON Semiconductor. “Typical” parameters which may be provided in ON Semiconductor data sheets and/or specifications can and do vary in different applications and actual performance may vary over time. All operating parameters, including “Typicals” must be validated for each customer application by customer’s technical experts. ON Semiconductor does not convey any license under its patent rights nor the rights of others. ON Semiconductor products are not designed, intended, or authorized for use as a critical component in life support systems or any FDA Class 3 medical devices or medical devices with a same or similar classification in a foreign jurisdiction or any devices intended for implantation in the human body. Should Buyer purchase or use ON Semiconductor products for any such unintended or unauthorized application, Buyer shall indemnify and hold ON Semiconductor and its officers, employees, subsidiaries, affiliates, and distributors harmless against all claims, costs, damages, and expenses, and reasonable attorney fees arising out of, directly or indirectly, any claim of personal injury or death associated with such unintended or unauthorized use, even if such claim alleges that ON Semiconductor was negligent regarding the design or manufacture of the part. ON Semiconductor is an Equal Opportunity/Affirmative Action Employer. This literature is subject to all applicable copyright laws and is not for resale in any manner.

PUBLICATION ORDERING INFORMATION

LITERATURE FULFILLMENT:

Literature Distribution Center for ON Semiconductor
19521 E. 32nd Pkwy, Aurora, Colorado 80011 USA
Phone: 303-675-2175 or 800-344-3860 Toll Free USA/Canada
Fax: 303-675-2176 or 800-344-3867 Toll Free USA/Canada
Email: orderlit@onsemi.com

N. American Technical Support: 800-282-9855 Toll Free
USA/Canada.
Europe, Middle East and Africa Technical Support:
Phone: 421 33 790 2910

ON Semiconductor Website: www.onsemi.com

Order Literature: <http://www.onsemi.com/orderlit>

For additional information, please contact your local
Sales Representative