

# Section 6: System Grounding

Bill Brown, P.E., Square D Engineering Services

## Introduction

The topic of system grounding is extremely important, as it affects the susceptibility of the system to voltage transients, determines the types of loads the system can accommodate, and helps to determine the system protection requirements.

The system grounding arrangement is determined by the grounding of the power source. For commercial and industrial systems, the types of power sources generally fall into four broad categories:

- A Utility Service – The system grounding is usually determined by the secondary winding configuration of the upstream utility substation transformer.
- B Generator – The system grounding is determined by the stator winding configuration.
- C Transformer – The system grounding on the system fed by the transformer is determined by the transformer secondary winding configuration.
- D Static Power Converter – For devices such as rectifiers and inverters, the system grounding is determined by the grounding of the output stage of the converter.

Categories A to D fall under the NEC definition for a “separately-derived system.” The recognition of a separately-derived system is important when applying NEC requirements to system grounding, as discussed below.

All of the power sources mentioned above except “D” are magnetically-operated devices with windings. To understand the system voltage relationships with respect to system grounding, it must be recognized that there are two common ways of connecting device windings: wye and delta. These two arrangements, with their system voltage relationships, are shown in figure 6-1. As can be seen from the figure, in the wye-connected arrangement there are four terminals, with the phase-to-neutral voltage for each phase set by the winding voltage and the resulting phase-to-phase voltage set by the vector relationships between the voltages. The delta configuration has only three terminals, with the phase-to-phase voltage set by the winding voltages and the neutral terminal not defined.

Neither of these arrangements is inherently associated with any particular system grounding arrangement, although some arrangements more commonly use one arrangement vs. the other for reasons that will be explained further below.

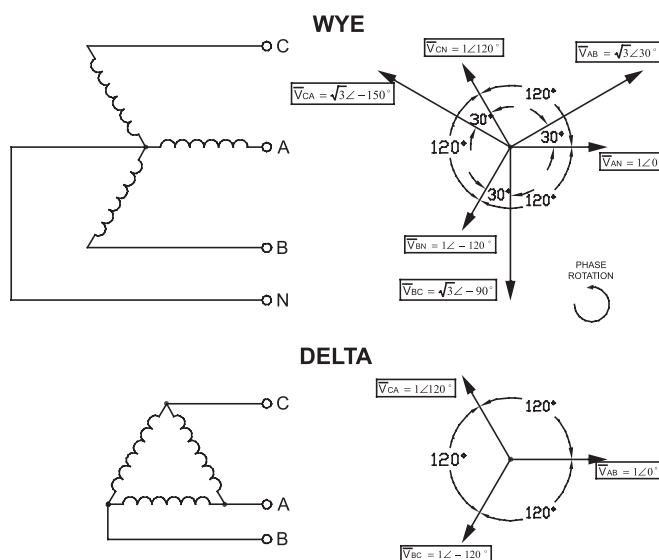
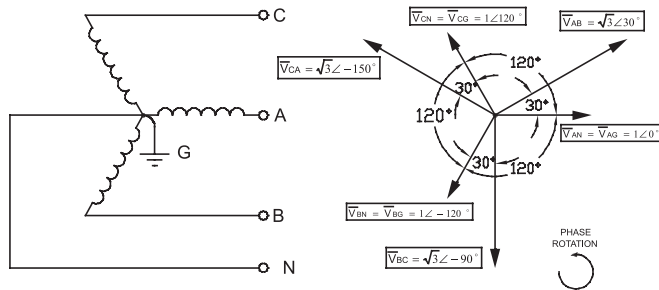

Figure 6-1: Wye and delta winding configurations and system voltage relationships

## Solidly-grounded systems

The solidly-grounded system is the most common system arrangement, and one of the most versatile. The most commonly-used configuration is the solidly-grounded wye, because it will support single-phase phase-to-neutral loads.

The solidly-grounded wye system arrangement can be shown by considering the neutral terminal from the wye system arrangement in figure 6-1 to be grounded. This is shown in figure 6-2:



**Figure 6-2: Solidly-Grounded Wye System arrangement and voltage relationships**

Several points regarding figure 6-2 can be noted.

First, the system voltage with respect to ground is fixed by the phase-to-neutral winding voltage. Because parts of the power system, such as equipment frames, are grounded, and the rest of the environment essentially is at ground potential also, this has big implications for the system. It means that the line-to-ground insulation level of equipment need only be as large as the phase-to-neutral voltage, which is 57.7% of the phase-to-phase voltage. It also means that the system is less susceptible to phase-to-ground voltage transients.

Second, the system is suitable for supplying line-to-neutral loads. The operation of a single-phase load connected between one phase and neutral will be the same on any phase since the phase voltage magnitudes are equal.

This system arrangement is very common, both at the utilization level as 480 Y/277 V and 208 Y/120 V, and also on most utility distribution systems.

While the solidly-grounded wye system is by far the most common solidly-grounded system, the wye arrangement is not the only arrangement that can be configured as a solidly grounded system. The delta system can also be grounded, as shown in figure 6-3. Compared with the solidly-grounded wye system of figure 6-2 this system grounding arrangement has a number of disadvantages. The phase-to-ground voltages are not equal, and therefore the system is not suitable for single-phase loads. And, without proper identification of the phases there is the risk of shock since one conductor, the B-phase, is grounded and could be mis-identified. This arrangement is no longer in common use, although a few facilities where this arrangement is used still exist.

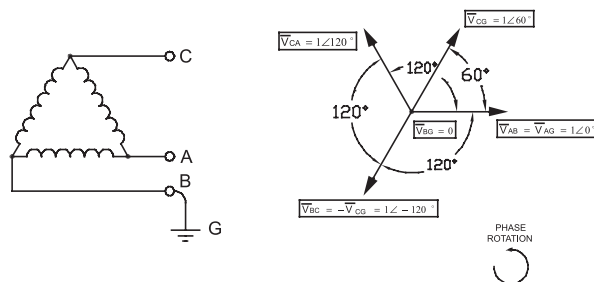

**Figure 6-3: Corner-Grounded Delta System arrangement and voltage relationships**

The delta arrangement can be configured in another manner, however, that does have merits as a solidly-grounded system. This arrangement is shown in figure 6-4. While the arrangement of figure 6-4 may not appear at first glance to have merit, it can be seen that this system is suitable both for three-phase and single-phase loads, so long as the single-phase and three-phase load cables are kept separate from each other. This is commonly

used for small services which require both 240 VAC three-phase and 120/240 VAC single-phase. Note that the phase A voltage to ground is 173% of the phase B and C voltages to ground. This arrangement requires the BC winding to have a center tap.

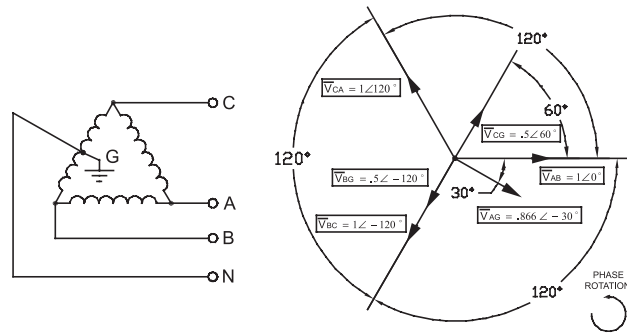

**Figure 6-4: Center-Tap-Grounded Delta System arrangement and voltage relationships**

A common characteristic of all three solidly-grounded systems shown here, and of solidly-grounded systems in general, is that a short-circuit to ground will cause a large amount of short-circuit current to flow. This condition is known as a ground fault and is illustrated in figure 6-5. As can be seen from figure 6-5, the voltage on the faulted phase is depressed, and a large current flows in the faulted phase since the phase and fault impedance are small. The voltage and current on the other two phases are not affected. The fact that a solidly-grounded system will support a large ground fault current is an important characteristic of this type of system grounding and does affect the system design. Statistically, 90-95% of all system short-circuits are ground faults so this is an important topic. The practices used in ground-fault protection are described in a later section of this guide.

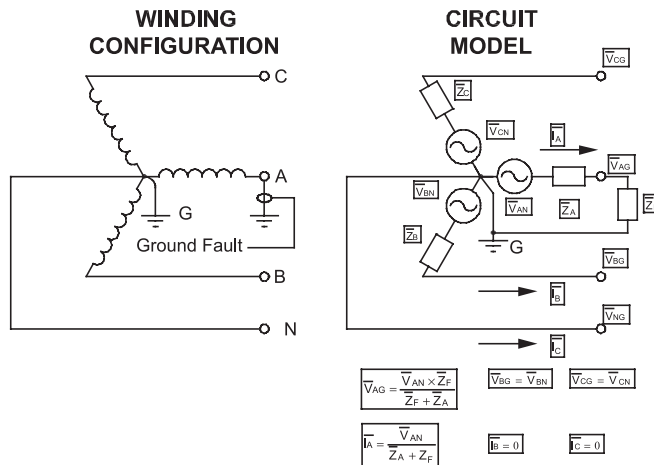

**Figure 6-5: Solidly-Grounded System with a ground fault on phase A**

The occurrence of a ground fault on a solidly-grounded system necessitates the removal of the fault as quickly as possible. This is the major disadvantage of the solidly-grounded system as compared to other types of system grounding.

A solidly-grounded system is very effective at reducing the possibility of line-to-ground voltage transients. However, to do this the system must be effectively grounded. One measure of the effectiveness of the system grounding is the ratio of the available ground-fault current to the available three-phase fault current. For effectively-grounded systems this ratio is usually at least 60% [2].

Most utility systems which supply service for commercial and industrial systems are solidly grounded. Typical utility practice is to ground the neutral at many points, usually at every line pole, creating a multi-grounded neutral system. Because a separate grounding conductor is not run with the utility line, the resistance of the earth limits the circulating ground currents that can be caused by this type of grounding. Because separate grounding conductors are used inside a commercial or industrial facility, multi-grounded neutrals are not preferred for power systems in these facilities due to the possibility of circulating ground currents. As will be explained later in this

section, multi-grounded neutrals in NEC jurisdictions, such as commercial or industrial facilities, are actually prohibited in most cases by the NEC [1]. Instead, a single point of grounding is preferred for this type of system, creating a uni-grounded or single-point grounded system.

In general, the solidly-grounded system is the most popular, is required where single-phase phase-to-neutral loads must be supplied, and has the most stable phase-to-ground voltage characteristics. However, the large ground fault currents this type of system can support, and the equipment that this necessitates, are a disadvantage and can be hindrance to system reliability.

## Ungrounded systems

This system grounding arrangement is at the other end of the spectrum from solidly-grounded systems. An ungrounded system is a system where there is no intentional connection of the system to ground.

The term “ungrounded system” is actually a misnomer, since every system is grounded through its inherent charging capacitance to ground. To illustrate this point and its effect on the system voltages to ground, the delta winding configuration introduced in figure 6-3 is re-drawn in figure 6-6 to show these system capacitances.

If all of the system voltages in figure 6-6 are multiplied by  $\sqrt{3}$  and all of the phase angles are shifted by  $30^\circ$  (both are reasonable operations since the voltage magnitudes and phase angles for the phase-to-phase voltage were arbitrarily chosen), the results are the same voltage relationships as shown in figure 6-4 for the solidly-grounded wye system. The differences between the ungrounded delta system and the solidly-grounded wye system, then, are that there is no intentional connection to ground, and that there is no phase-to-neutral driving voltage on the ungrounded delta system. This becomes important when the effects of a ground fault are considered. The lack of a grounded system neutral also makes this type of system unsuitable for single-phase phase-to-neutral loads.

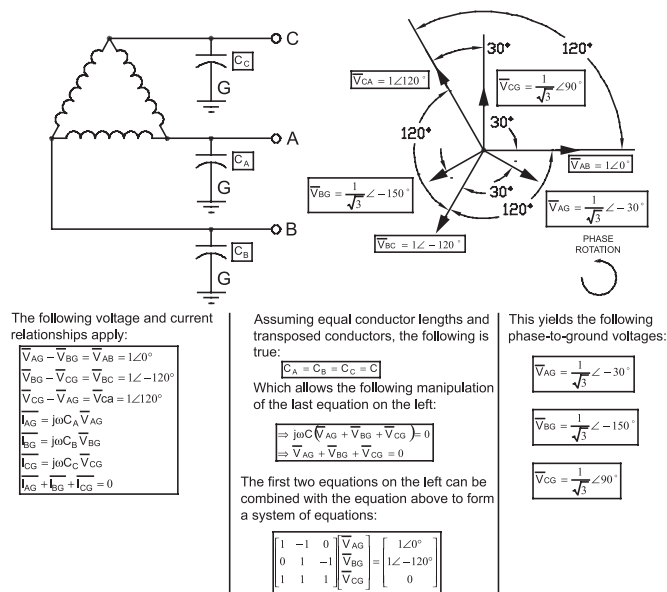

**Figure 6-6: Ungrounded Delta System winding arrangement and voltage relationships**

In figure 6-7, the effects of a single phase to ground fault are shown. The equations in figure 6-7 are not immediately practical for use, however if the fault impedance is assumed to be zero and the system capacitive charging impedance is assumed to be much larger than the phase impedances, these equations reduce into a workable form. Figure 6-8 shows the resulting equations, and shows the current and voltage phase relationships.

As can be seen from figure 6-8, the net result of a ground fault on one phase of an ungrounded delta system is a change in the system phase-to-ground voltages. The phase-to-ground voltage on the faulted phase is zero, and the phase-to-ground voltage on the unfaulted phases are 173% of their nominal values. This has implications for power equipment – the phase-to-ground voltage rating for equipment on an ungrounded system must be at least equal the phase-to-phase voltage rating. This also has implications for the methods used for ground detection, as explained later in this guide.

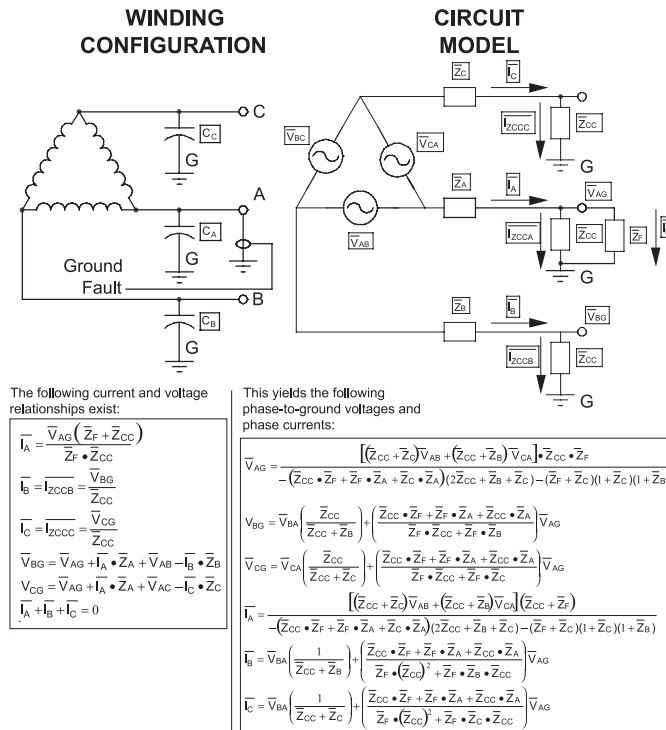

**Figure 6-7: Ungrounded Delta System with a ground-fault on one phase**

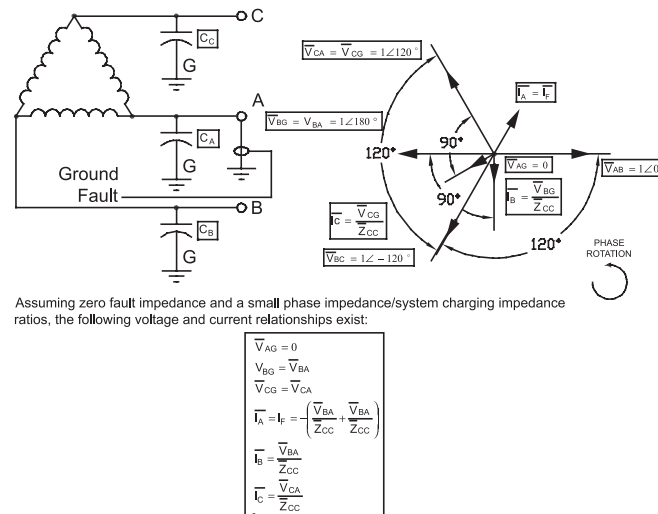

**Figure 6-8: Ungrounded Delta System – simplified ground fault voltage and current relationships**

The ground currents with one phase is faulted to ground are essentially negligible. Because of this fact, from an operational standpoint ungrounded systems have the advantage of being able to remain in service if one phase is faulted to ground. However, suitable ground detection must be provided to alarm this condition (and is required in most cases by the NEC [1] as described below). In some older facilities, it has been reported that this type of system has remained in place for 40 years or more with one phase grounded! This condition is not dangerous in and of itself (other than due to the increased phase-to-ground voltage on the unfaulted phases), however if a ground fault occurs on one of the ungrounded phases the result is a phase-to-phase fault with its characteristic large fault current magnitude.

Another important consideration for an ungrounded system is its susceptibility to large transient overvoltages. These can result from a resonant or near-resonant condition during ground faults, or from arcing [2]. A resonant ground fault condition occurs when the inductive reactance of the ground-fault path approximately equals the

system capacitive reactance to ground. Arcing introduces the phenomenon of current-chopping, which can cause excessive overvoltages due to the system capacitance to ground.

The ground detection mentioned above can be accomplished through the use of voltage transformers connected in wye-broken delta, as illustrated in figure 6-9.

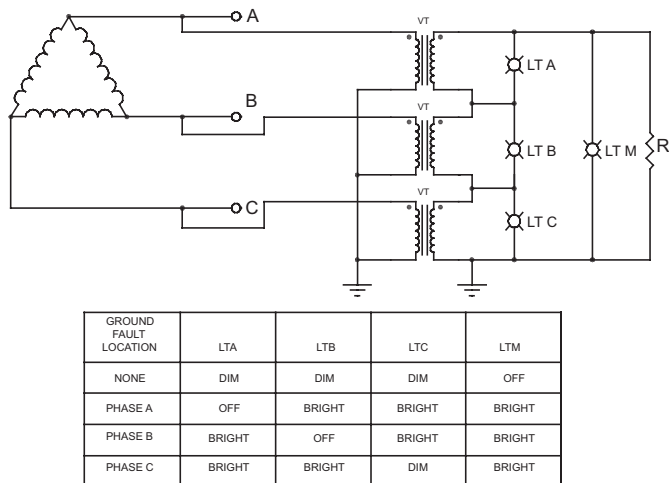

**Figure 6-9: A Ground Detection method for ungrounded systems**

In figure 6-9, three ground detection lights “LTA,” “LTB” and “LTC” are connected so that they indicate the A, B and C phase-to-ground voltages, respectively. A master ground detection light “LTM” indicates a ground fault on any phase. With no ground fault on the system “LTA,” “LTB” and “LTC” will glow dimly. If a ground fault occurs on one phase, the light for that phase will be extinguished and “LTM” will glow brightly along with the lights for the other two phases. Control relays may be substituted for the lights if necessary. Resistor “R” is connected across the broken-delta voltage transformer secondaries to minimize the possibility of ferroresonance. Most ground detection schemes for ungrounded systems use this system or a variant thereof.

Note that the ground detection per figure 6-10 indicates on which phase the ground fault occurs, but not where in the system the ground fault occurs. This, along with the disadvantages of ungrounded systems due to susceptibility to voltage transients, was the main impetus for the development of other ground system arrangements.

Modern power systems are rarely ungrounded due to the advent of high-resistance grounded systems as discussed below. However, older ungrounded systems are occasionally encountered.

## High-resistance grounded systems

One ground arrangement that has gained in popularity in recent years is the high-resistance grounding arrangement. For low voltage systems, this arrangement typically consists of a wye winding arrangement with the neutral connected to ground through a resistor. The resistor is sized to allow 1-10 A to flow continuously if a ground fault occurs. This arrangement is illustrated in figure 6-10.

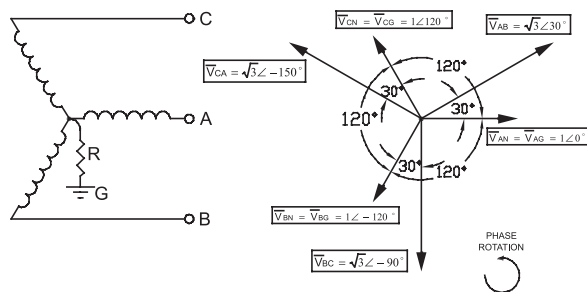

**Figure 6-10: High-Resistance Grounded System with no ground fault present**

The resistor is sized to be less than or equal to the magnitude of the system charging capacitance to ground. If the resistor is thus sized, the high-resistance grounded system is usually not susceptible to the large transient overvoltages that an ungrounded system can experience. The ground resistor is usually provided with taps to allow field adjustment of the resistance during commissioning.

If no ground fault current is present, the phasor diagram for the system is the same as for a solidly-grounded wye system, as shown in figure 6-10. However, if a ground fault occurs on one phase the system response is as shown in figure 6-11. As can be seen from figure 6-11, the ground fault current is limited by the grounding resistor. If the approximation is made that  $\bar{Z}_A$  and  $\bar{Z}_F$  are very small compared to the ground resistor resistance value R, which is a good approximation if the fault is a bolted ground fault, then the ground fault current is approximately equal to the phase-to-neutral voltage of the faulted phase divided by R. The faulted phase voltage to ground in that case would be zero and the unfaulted phase voltages to ground would be 173% of their values without a ground fault present. This is the same phenomenon exhibited by the ungrounded system arrangement, except that the ground fault current is larger and approximately in-phase with the phase-to-neutral voltage on the faulted phase. The limitation of the ground fault current to such a low level, along with the absence of a solidly-grounded system neutral, has the effect of making this system ground arrangement unsuitable for single-phase line-to-neutral loads.

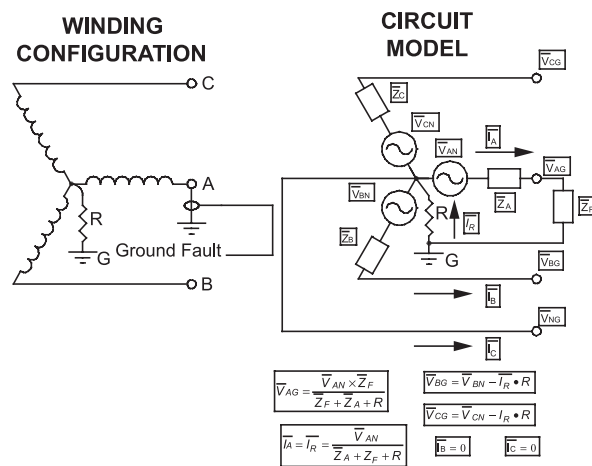
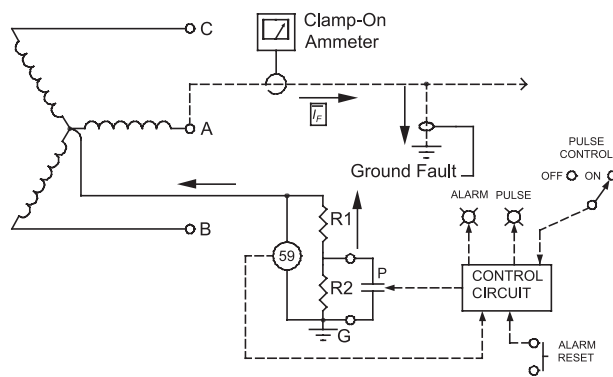

**Figure 6-11: High-Resistance Grounded System with a ground fault on one phase**

The ground fault current is not large enough to force its removal by taking the system off-line. Therefore, the high-resistance grounded system has the same operational advantage in this respect as the ungrounded system. However, in addition to the improved voltage transient response as discussed above, the high-resistance grounded system has the advantage of allowing the location of a ground fault to be tracked.

A typical ground detection system for a high-resistance grounded system is illustrated in figure 6-12. The ground resistor is shown with a tap between two resistor sections R1 and R2. When a ground fault occurs, relay 59 (the ANSI standard for an overvoltage relay, as discussed later in this guide) detects the increased voltage across the resistor. It sends a signal to the control circuitry to initiate a ground fault alarm by energizing the “alarm” indicator. When the operator turns the pulse control selector to the “ON” position, the control circuit causes pulsing contact P to close and re-open approximately once per second. When P closes R2 is shorted and the “pulse” indicator is energized. R1 and R2 are sized so that approximately 5-7 times the resistor continuous ground fault current flows when R2 is shorted. The result is a pulsing ground fault current that can be detected using a clamp-on ammeter (an analog ammeter is most convenient). By tracing the circuit with the ammeter, the ground fault location can be determined. Once the ground fault has been removed from the system pressing the “alarm reset” button will de-energize the “alarm” indicator.

This type of system is known as a **pulsing ground detection system** and is very effective in locating ground faults, but is generally more expensive than the ungrounded system ground fault indicator in figure 6-10.



**Figure 6-12: Pulsing Ground Detection System**

For medium voltage systems, high-resistance grounding is usually implemented using a low voltage resistor and a neutral transformer, as shown in figure 6-13.

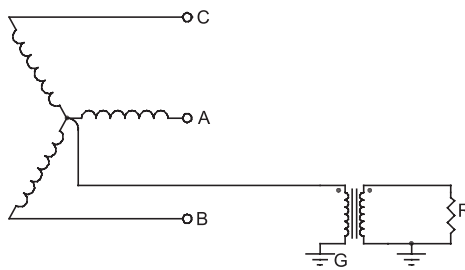

**Figure 6-13: Medium Voltage implementation for high-resistance grounding**

## Reactance grounding

In industrial and commercial facilities, reactance grounding is commonly used in the neutrals of generators. In most generators, solid grounding may permit the level of ground-fault current available from the generator to exceed the three-phase value for which its windings are braced [2]. For these cases, grounding of the generator neutral through an air-core reactance is the standard solution for lowering the ground fault level. This reactance ideally limits the ground-fault current to the three-phase available fault current and will allow the system to operate with phase-to-neutral loads.

## Low-resistance grounded systems

By sizing the resistor in figure in 6-11 such that a higher ground fault current, typically 200-800 A, flows during a ground fault a low-resistance grounded system is created. The ground fault current is limited, but is of high enough magnitude to require its removal from the system as quickly as possible. The low-resistance grounding arrangement is typically used in medium voltage systems which have only 3-wire loads, such as motors, where limiting damage to the equipment during a ground fault is important enough to include the resistor but it is acceptable to take the system offline for a ground fault. The low-resistance grounding arrangement is generally less expensive than the high-resistance grounding arrangement but more expensive than a solidly grounded system arrangement.

## Creating an artificial neutral in an ungrounded system

In some cases it is required to create a neutral reference for an ungrounded system. Most instances involve existing ungrounded systems which are being upgraded to high-resistance grounding. The existence of multiple transformers and/or delta-wound generators may make the replacement of this equipment economically unfeasible.



The solution is a grounding transformer. Although several different configurations exist, by far the most popular in commercial and industrial system is the zig-zag transformer arrangement. It uses transformers connected as shown in figure 6-14:

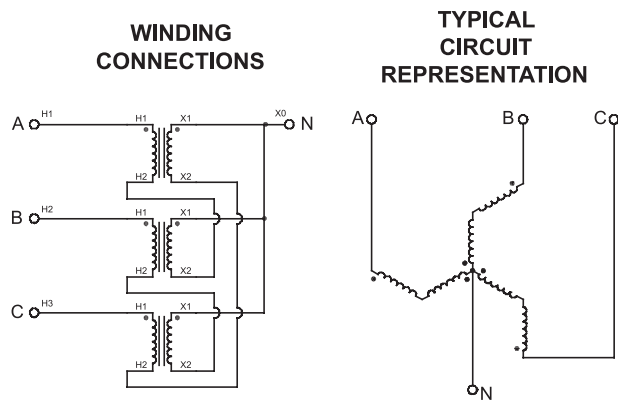

**Figure 6-14: Zig-Zag grounding transformer arrangement**

The zig-zag transformer will only pass ground current. Its typical implementation on an ungrounded system, in order to convert the system to a high-resistance grounded system, is shown in figure 6-15. The zig-zag transformer distributes the ground current  $I_G$  equally between the three phases. For all practical purposes the system, from a grounding standpoint, behaves as a high-resistance grounded system.

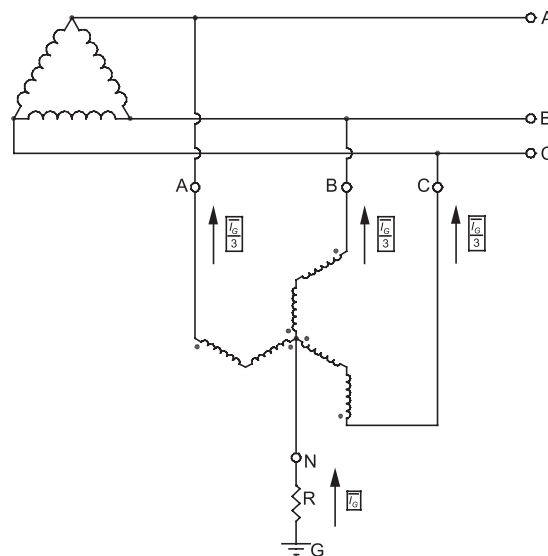

**Figure 6-15: Zig-Zag grounding transformer implementation**

The solidly-grounded and low-resistance grounded systems can also be implemented by using a grounding transformer, depending upon the amount of impedance connected in the neutral.

## NEC system grounding requirements

The National Electrical Code [1] does place constraints on system grounding. While this guide is not intended to be a definitive guide to all NEC requirements, several points from the NEC must be mentioned and are based upon the basic principles stated above. As a starting point, several key terms from the NEC need to be defined:

**Ground:** A conducting connection, whether intentional or accidental, between an electrical circuit or equipment and the earth or to some body that serves in place of the earth.

**Grounded:** Connected to earth or to some body that serves in place of the earth.

**Effectively Grounded:** Intentionally connected to earth through a ground connection or connections of sufficiently low impedance and having sufficient current-carrying capacity to prevent the buildup of voltages that may result in undue hazards to connected equipment or to persons.

**Grounded Conductor:** A system or circuit conductor that is intentionally grounded.

**Solidly Grounded:** Connected to ground without inserting any resistor or impedance device.

**Grounding Conductor:** A conductor used to connect equipment or the grounded circuit of a wiring system to a grounding electrode or electrodes.

**Equipment Grounding Conductor:** The conductor used to connect the non-current-carrying metal parts of equipment, raceways and other enclosures to the system grounded conductor, grounding electrode conductor, or both, at the service equipment or at the source of a separately-derived system.

**Main Bonding Jumper:** The connection between the grounded circuit conductor and the equipment grounding conductor at the service.

**System Bonding Jumper:** The connection between the grounded circuit conductor and the equipment grounding conductor at a separately-derived system.

**Grounding Electrode:** The conductor used to connect the grounding electrode(s) to the equipment grounding conductor, to the grounded conductor, or to both, at the service, at each building or structure where supplied by a feeder(s) or branch circuit(s), or at the source of a separately-derived system.

**Grounding Electrode Conductor:** The conductor used to connect the grounding electrode(s) to the equipment grounding conductor, to the grounded conductor, or to both, at the service, at each building or structure where supplied by a feeder(s) or branch circuit(s), or at the source of a separately-derived system.

**Ground Fault:** An unintentional, electrically conducting connection between an ungrounded conductor of an electrical circuit and the normally non-current-carrying conductors, metallic enclosures, metallic raceways, metallic equipment, or earth.

**Ground Fault Current Path:** An electrically conductive path from the point of a ground fault on a wiring system through normally non-current-carrying conductors, equipment, or the earth to the electrical supply source.

**Effective Ground-Fault Current Path:** An intentionally constructed, permanent, low-impedance electrically conductive path designed and intended to carry current under ground-fault conditions from the point of a ground fault on a wiring system to the electrical supply source and that facilitates the operation of the overcurrent protective device or ground fault detectors on high-impedance grounded systems.

**Ground-Fault Circuit Interrupter:** A device intended for the protection of personnel that functions to de-energize a circuit or portion thereof within an established period of time when a current to ground exceeds the values established for a Class A device.

**FPN:** Class A ground-fault circuit interrupters trip when the current to ground has a value in the range of 4 mA to 6 mA. For further information, see UL 943, Standard for Ground-Fault Circuit Interrupters.

**Ground Fault Protection of Equipment:** A system intended to provide protection of equipment from damaging line-to-ground fault currents by operating to cause a disconnecting means to open all ungrounded conductors of the faulted circuit. This protection is provided at current levels less than those required to protect conductors from damage through the operation of a supply circuit overcurrent device.

**Qualified Person:** One who has the skills and knowledge related to the construction and operation of the electrical equipment and installations and has received safety training on the hazards involved.

With these terms defined, several of the major components of the grounding system can be illustrated by redrawing the system of figure 6-2 and labeling the components:

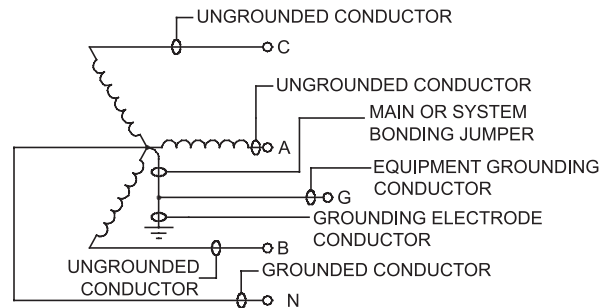

**Figure 6-16: NEC [1] system grounding terms illustration**

Several key design constraints for grounding systems from the NEC [1] are as follows. These are paraphrased from the code text (Note: This guide is not intended as a substitute for familiarity with the NEC, nor is it intended as an authoritative interpretation of every aspect of the NEC articles mentioned.):

- Electrical systems that are grounded must be grounded in such a manner as to limit the voltage imposed by lightning, line surges, or unintentional contact with higher voltage lines and that will stabilize the voltage to earth during normal operation [Article 250.4(A)(1)]. In other words, if a system is considered solidly grounded the ground impedance must be low.
- If the system can be solidly grounded at 150 V to ground or less, it must be solidly grounded [Article 250.20(B)]. There is therefore no such system as a “120 V Ungrounded Delta” in use, even though such a system is physically possible.
- If the system neutral carries current it must be solidly grounded [Article 250.20(B)]. This is indicative of single-phase loading and is typical for a 4-wire wye (such as figure 6-2) or center-tapped 4-wire delta (such as figure 6-4) system.
- Certain systems are permitted, but not required, to be solidly grounded. They are listed as electric systems used exclusively to supply industrial electric furnaces for melting, refining, tempering, and the like, separately derived systems used exclusively for rectifiers that supply only adjustable-speed industrial drives, and separately derived systems supplied by transformers that have a primary voltage rating less than 1000 volts provided that certain conditions are met [Article 250.21].
- If a system 50-1000 VAC is not solidly-grounded, ground detectors must be installed on the system unless the voltage to ground is less than 120 V [Article 250.21].
- Certain systems cannot be grounded. They are listed as circuits for electric cranes operating over combustible fibers in Class III locations as provided in Article 503.155, circuits within hazardous (classified) anesthetizing locations and other isolated power systems in health care facilities as provided in 517.61 and 517.160, circuits for equipment within electrolytic cell working zone as provided in Article 668, and secondary circuits of lighting systems as provided in 411.5(A) [Article 250.22]. Some of the requirements for hazardous locations and health care facilities are covered in section XVI.
- For solidly-grounded systems, an unspliced main bonding jumper must be used to connect the equipment grounding conductor(s) and the service disconnect enclosure to the grounded conductor within the enclosure for each utility service disconnect [Article 250.24(B)].
- For solidly-grounded systems, an unspliced system bonding jumper must be used to connect the equipment grounding conductor of a separately derived system to the grounded conductor. This connection must be made at any single point on the separately derived system from the source to the first system disconnecting means or overcurrent device [250.30(A)(1)]
- A grounding connection on the load side of the main bonding or system bonding jumper on a solidly-grounded system is not permitted [Articles 240.24(A)(5), 250.30(A)]. The reasons for this are explained in below and in section VIII.

- Ground fault protection of equipment must be provided for solidly grounded wye electrical services, feeder disconnects on solidly-grounded wye systems, and building or structure disconnects on solidly-grounded wye systems under the following conditions:
  - ◆ The voltage is greater than 150 V to ground, but does not exceed 600 V phase-to-phase.
  - ◆ The utility service, feeder, or building or structure disconnect is rated 1000 A or more.
  - ◆ The disconnect in question does not supply a fire pump or continuous industrial process.

[Articles 215.10, 230.95, 240.13].

- Where ground fault protection is required per Article 215.10 or 230.95 for a health care facility, an additional step of ground fault protection is required in the next downstream device toward the load, with the exception of circuits on the load side of an essential electrical system transfer switch and between on-site generating units for the essential electrical system and the essential electrical system transfer switches [Article 517.17]. Specific requirements for health-care systems are described in a later section of this guide.
- The alternate source for an emergency or legally-required standby system is not required to have ground fault protection. For an emergency system, ground-fault indication is required [Articles 700.26, 701.17]. A later section of this guide describes the requirements for Emergency and Standby Power Systems.
- All electrical equipment, wiring, and other electrically conductive material must be installed in a manner that creates a permanent, low-impedance path facilitating the operation of the overcurrent device. This circuit must be able to safely carry the ground fault current imposed upon it. [Article 250.4(A)(5)]. The intent of this requirement is to allow ground fault current magnitudes to be sufficient for the ground fault protection/detection to detect (and for ground fault protection to clear) the fault, and for a ground fault not to cause damage to the grounding system.
- High-impedance grounded systems may be utilized on AC systems of 480-1000 V where:
  - ◆ Conditions of maintenance and supervision ensure that only qualified persons access the installation.
  - ◆ Continuity of power is required.
  - ◆ Ground detectors are installed on the system.
  - ◆ Line-to-neutral loads are not served.

[Article 250.36]

- For systems over 1000 V:
  - ◆ The system neutral for solidly-grounded systems may be a single point grounded or multigrounded neutral. Additional requirements for each of these arrangements apply [Article 250.184].
  - ◆ The system neutral derived from a grounding transformer may be used for grounding [Article 250.182].
  - ◆ The minimum insulation level for the neutral of a solidly-grounded system is 600 V. A bare neutral is permissible under certain conditions [Article 250.184 (A) (1)].
  - ◆ Impedance grounded neutral systems may be used where conditions 1, 3, and 4 for the use of high-impedance grounding on systems 480-1000 V above are met [Article 250.186].
  - ◆ The neutral conductor must be identified and fully insulated with the same phase insulation as the phase conductors [Article 250.186 (B)].
- Zig-zag grounding transformers must not be installed on the load side of any system grounding connection [Article 450.5].
- When a grounding transformer is used to provide the grounding for a 3 phase 4 wire system, the grounding transformer must not be provided with overcurrent protection independent of the main switch and common-trip overcurrent protection for the 3 phase, 4 wire system [Article 450.5 (A) (1)]. An overcurrent sensing device must be provided that will cause the main switch or common-trip overcurrent protection to open if the load on the grounding transformer exceeds 125% of its continuous current rating [Article 450.5 (A) (2)].

Again, these points are not intended to be an all-inclusive reference for NEC grounding requirements. They do, however, summarize many of the major requirements. When in doubt, consult the NEC.

## References

- [1] The National Electrical Code, NFPA 70, The National Fire Protection Association, Inc., 2005 Edition.
- [2] IEEE Recommended Practice for Grounding of Industrial and Commercial Power Systems, IEEE Std. 142-1991, December 1991.