

PIN diodes in RF switch applications

About this document

Scope and purpose

This application note shows radio frequency (RF) switches for signal routing between different transmission paths with Infineon PIN diodes. The single-pole single-throw (SPST) and single-pole double-throw (SPDT) based switch structures are outlined. Various Infineon PIN diodes are used, namely [BAR50-02V](#), [BAR63-02L](#), [BAR64-02V](#) and [BAR90-02EL](#).

Intended audience

This document is intended for engineers who need to design RF PIN diode switches.

Table of contents

About this document	1
Table of contents	1
1 Introduction.....	3
1.1 RF switches	3
1.2 Infineon PIN diodes	5
2 PIN diode SPST switches.....	6
2.1 Sub-GHz range.....	6
2.1.1 Performance overview	6
2.1.2 Schematic.....	6
2.1.3 Bill of materials (BOM)	7
2.1.4 Evaluation board and layout information.....	7
2.1.5 Measurement graphs	9
2.2 S-band range	11
2.2.1 Performance overview	11
2.2.2 Schematic.....	11
2.2.3 BOM.....	12
2.2.4 Evaluation board and layout information.....	12
2.2.5 Measurement graphs	14
3 PIN diode SPDT series switches	16
3.1 Sub-GHz range.....	16
3.1.1 Performance overview	16
3.1.2 Schematic.....	17
3.1.3 BOM.....	18
3.1.4 Evaluation board and layout information.....	19
3.1.5 Measurement graphs	20
3.2 S-band range	23
3.2.1 Performance overview	23
3.2.2 Schematic.....	24
3.2.3 BOM.....	25

Introduction

3.2.4 Evaluation board and layout information..... 26

3.2.5 Measurement graphs 27

4 PIN diode SPDT series and shunt switches30

4.1 Sub-GHz range..... 30

4.1.1 Performance overview 30

4.1.2 Schematic..... 31

4.1.3 BOM..... 32

4.1.4 Evaluation board and layout information..... 33

4.1.5 Measurement graphs 34

4.2 S-band range 37

4.2.1 Performance overview 37

4.2.2 Schematic..... 38

4.2.3 BOM..... 39

4.2.4 Evaluation board and layout information..... 40

4.2.5 Measurement graphs 41

5 Author44

Revision history45

Introduction

1 Introduction

1.1 RF switches

Many applications require switching the RF signal path to route and connect to different antennas, filters and amplifiers. With the growth and development of wireless communication, high-speed data networks and other advanced technologies such as switchable band-pass filters, the need for high performance switching devices is increasing.

The PIN diode is one of the popular device options for switches. The PIN diode comprises three regions, namely the P-region (p-type semiconductor), I-region (intrinsic semiconductor) and N-region (n-type semiconductor). The wide intrinsic region in the PIN diode makes it suitable for fast switches, attenuators and high voltage power applications.

The two most common configurations of RF switches are shown in the following figures. The SPST switch has one input port and one output port, as shown in Figure 1. The SPST is a basic switch, which is used to connect or break the connection between the two terminals. It can be utilized to connect RF input to RF output by providing a positive bias voltage to the diode.

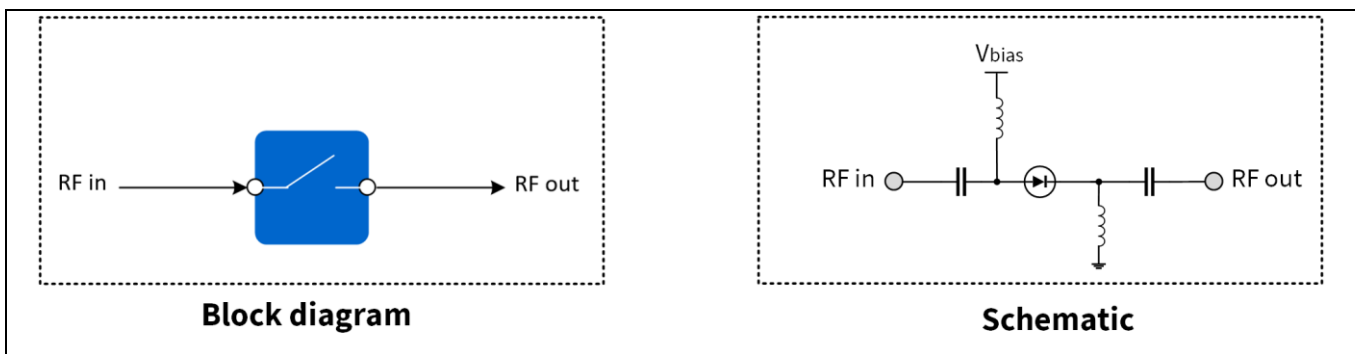

Figure 1 The SPST switch configuration

The SPDT switch has one common port and two output branches, as shown in Figure 2. The SPDT is ideal for use in Rx-Tx (receive-transmit) antenna switches. The SPDT schematic shown in Figure 2 contains one series diode in each branch of the switch. By providing positive bias voltage to the respective diode, the RF signal is routed from the common input port to either one of the two output branches.

Introduction

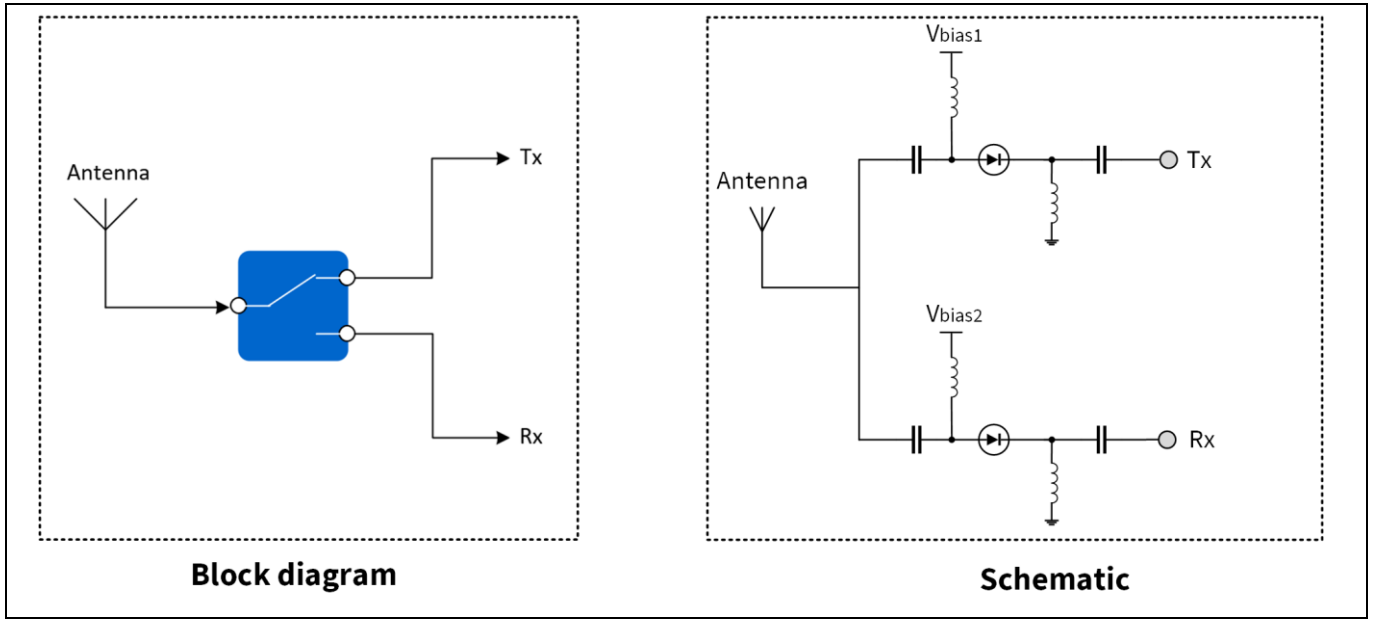

Figure 2 The SPDT series switch configuration

Adding a shunt PIN diode in each switching branch improves the isolation provided by the switch. Figure 3 shows the schematic of the SPDT series and shunt switch.

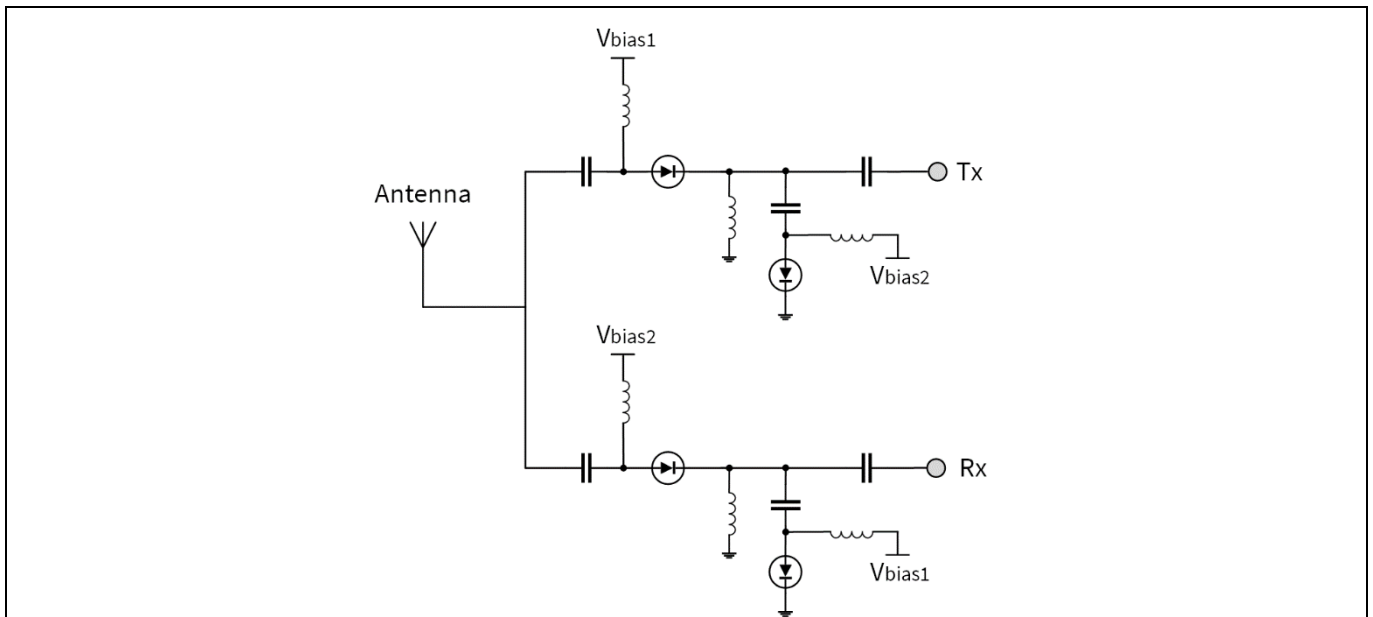

Figure 3 The SPDT series and shunt switch schematic

Introduction

1.2 Infineon PIN diodes

Infineon PIN diodes are ideal for a wide range of RF applications. Their low insertion loss and fast switching time makes them ideal for use in Rx-Tx antenna switches. They are offered in industry-standard 0201 and 0402 form factors as well as conventional industry packages and various junction diode configurations.

Key parameters of PIN diodes used in this application note are listed in Table 1.

Table 1 PIN diodes – key parameters

Product type	C_T at 0 V, $f = 1.8$ GHz [pF]	R_f at 10 mA [Ω]	τ_{rr} [ns]	Package
BAR50-02V	0.15	3.0	1100	SC79
BAR63-02L	0.3	1.0	75	TSLP-2
BAR64-02V	0.17	2.1	1550	SC79
BAR90-02EL	0.18	0.8	750	TSLP-2

PIN diode SPST switches

2 PIN diode SPST switches

2.1 Sub-GHz range

2.1.1 Performance overview

The following table shows the SPST switch performance with PIN diode [BAR63-02L](#).

Table 2 Summary of measurement results of SPST switch circuit

Parameter	Symbol	Value	Unit	Notes
Device		BAR63-02L		
Bias voltage	V_{bias}	3.3	V	On state
Bias current	I_{bias}	9.8	mA	On state
Frequency	f	300 to 1000	MHz	
Insertion loss (on state)	IL	0.24 ¹⁾ 0.20 ²⁾ 0.19 ³⁾	dB	SMA and PCB losses subtracted 1) Measured at 315 MHz (losses = 0.04 dB) 2) Measured at 434 MHz (losses = 0.04 dB) 3) Measured at 868 MHz (losses = 0.09 dB)
Input return loss	RL_{in}	>25	dB	
Output return loss	RL_{out}	>24.8	dB	
Isolation (off state)	ISO_{off}	24.4 ⁴⁾ 22.3 ⁵⁾ 16.9 ⁶⁾	dB	Off state ($I_{\text{bias}} = 0$ A) 4) Measured at 315 MHz 5) Measured at 434 MHz 6) Measured at 868 MHz
Input third order intercept point	IIP_3	> 45	dBm	Measured at $P_{\text{IN}} = 5$ dBm
Third order intermodulation distortion	IMD3	> 85	dBc	

2.1.2 Schematic

The following figure shows the schematic of the SPST switch. In the schematic, the resistor R1 is used to set the bias current. The inductor L2 provides the DC return path for the bias current. The capacitor C2 serves as the RF bypass. The input matching is achieved by the capacitor C1 and the inductor L1. The output matching network is formed by the capacitor C3 and the inductor L2.

PIN diode SPST switches

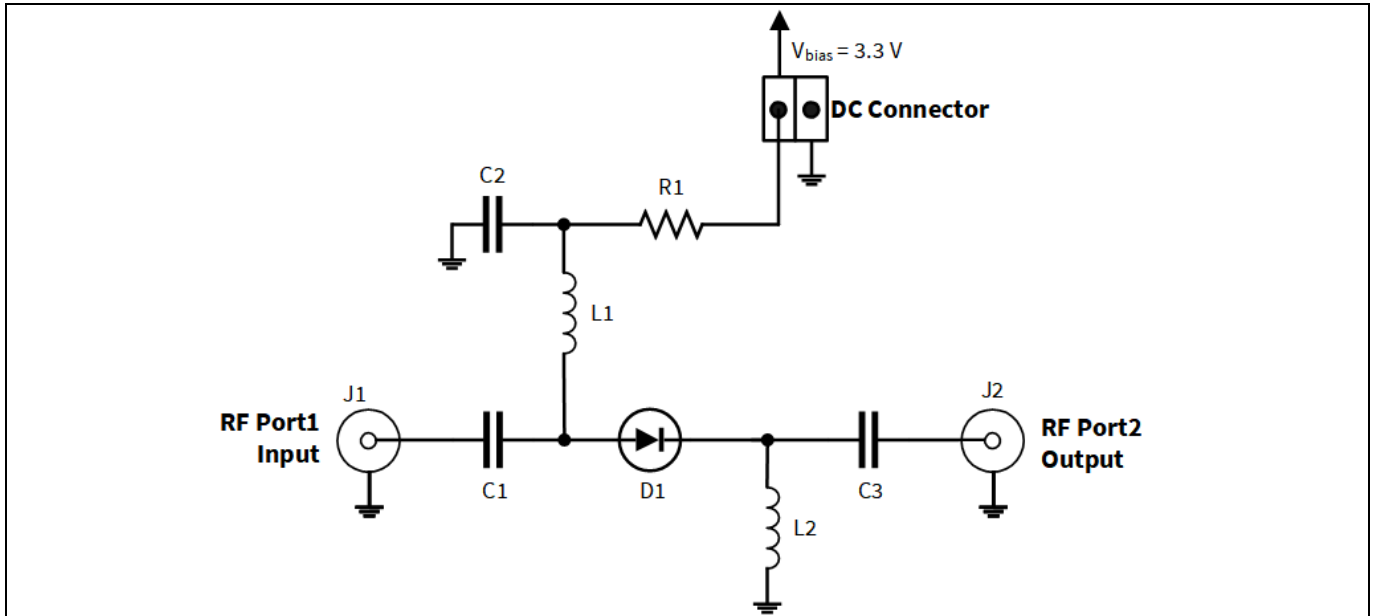

Figure 4 The SPST switch schematic

2.1.3 Bill of materials (BOM)

Table 3 BOM of the SPST switch circuit with [BAR63-02L](#)

Symbol	Value	Unit	Size	Manufacturer	Comment
D1	BAR63-02L	-	TSLP-2	Infineon	PIN diode
C1	22	pF	0402	Various	DC block and input matching
C2	220	nF	0402	Various	RF bypass
C3	22	pF	0402	Various	DC block and output matching
L1	68	nH	0402	Murata LQW	RF choke
L2	68	nH	0402	Murata LQW	DC return
R1	240	Ω	0402	Various	DC bias

2.1.4 Evaluation board and layout information

The evaluation board information for the SPST switch circuit with [BAR63-02L](#):

- PCB material: FR4
- PCB marking: M180629 RF Diode 3

Images of the evaluation board and the PCB stack information are shown in the following figures.

PIN diode SPST switches

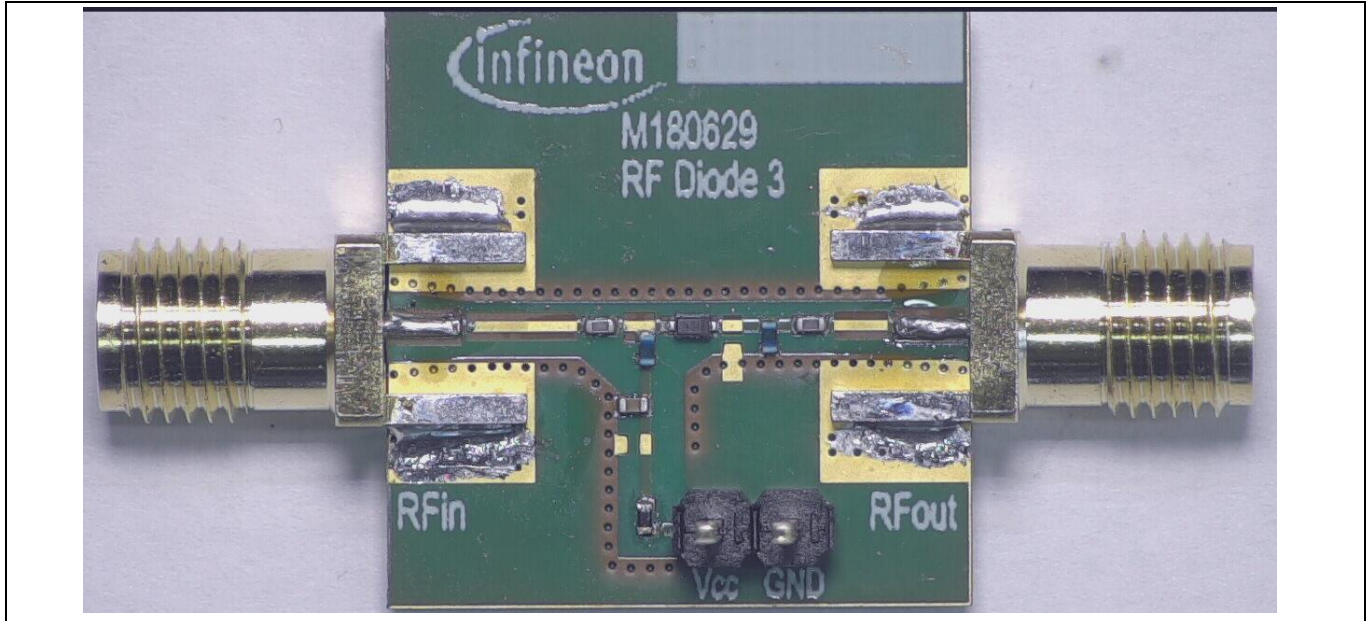

Figure 5 Photo of the evaluation board for PIN diode SPST switch with [BAR63-02L](#)

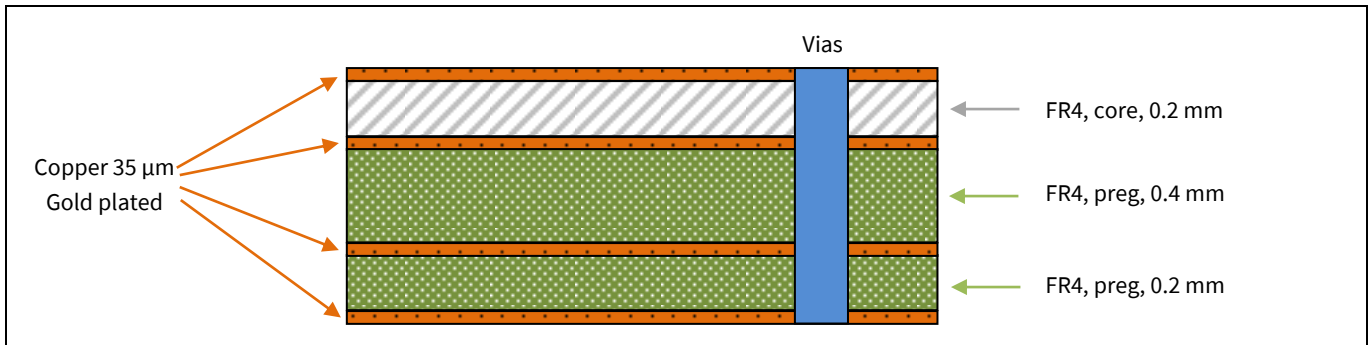

Figure 6 PCB stack information of the evaluation board for PIN diode SPST switch

PIN diode SPST switches

2.1.5 Measurement graphs

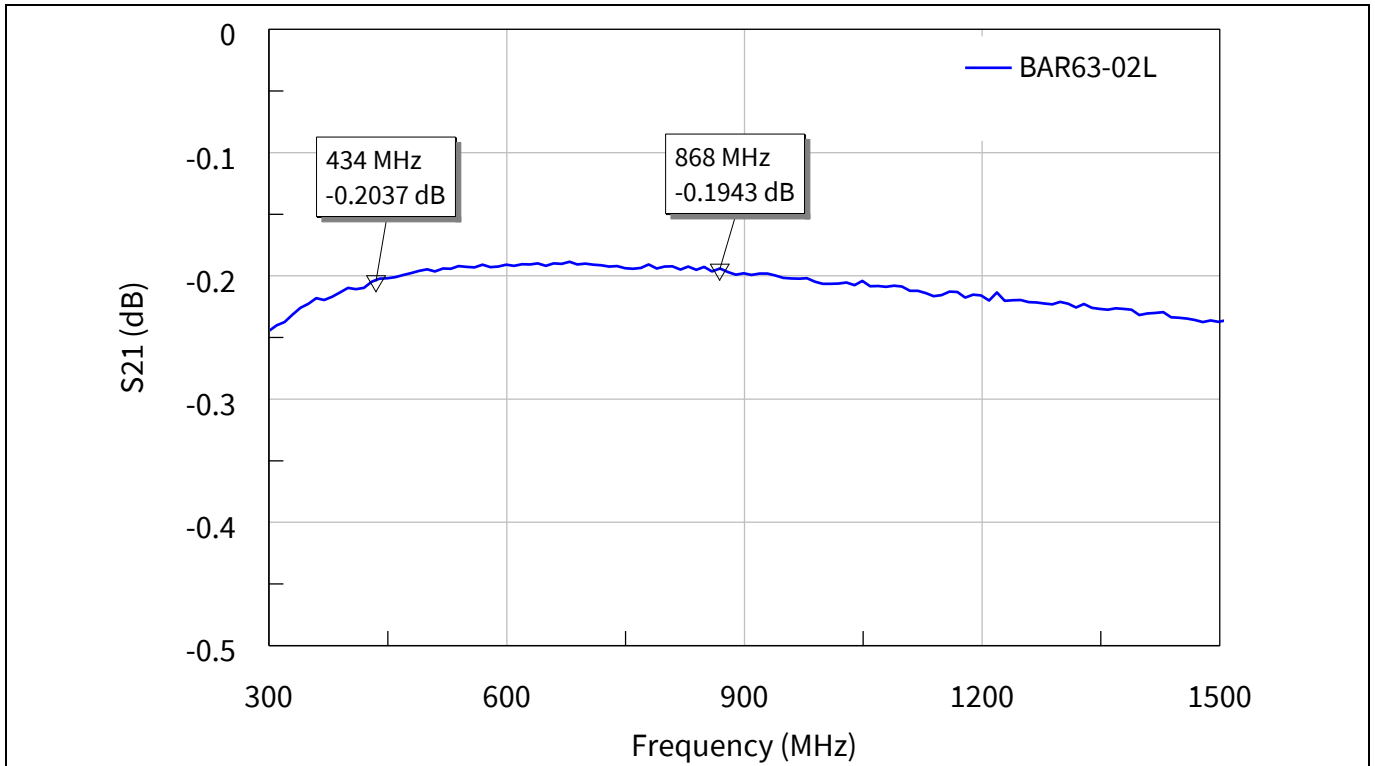

Figure 7 Insertion loss of PIN diode SPST switch with [BAR63-02L](#) in on state ($I_{bias} = 9.8$ mA)

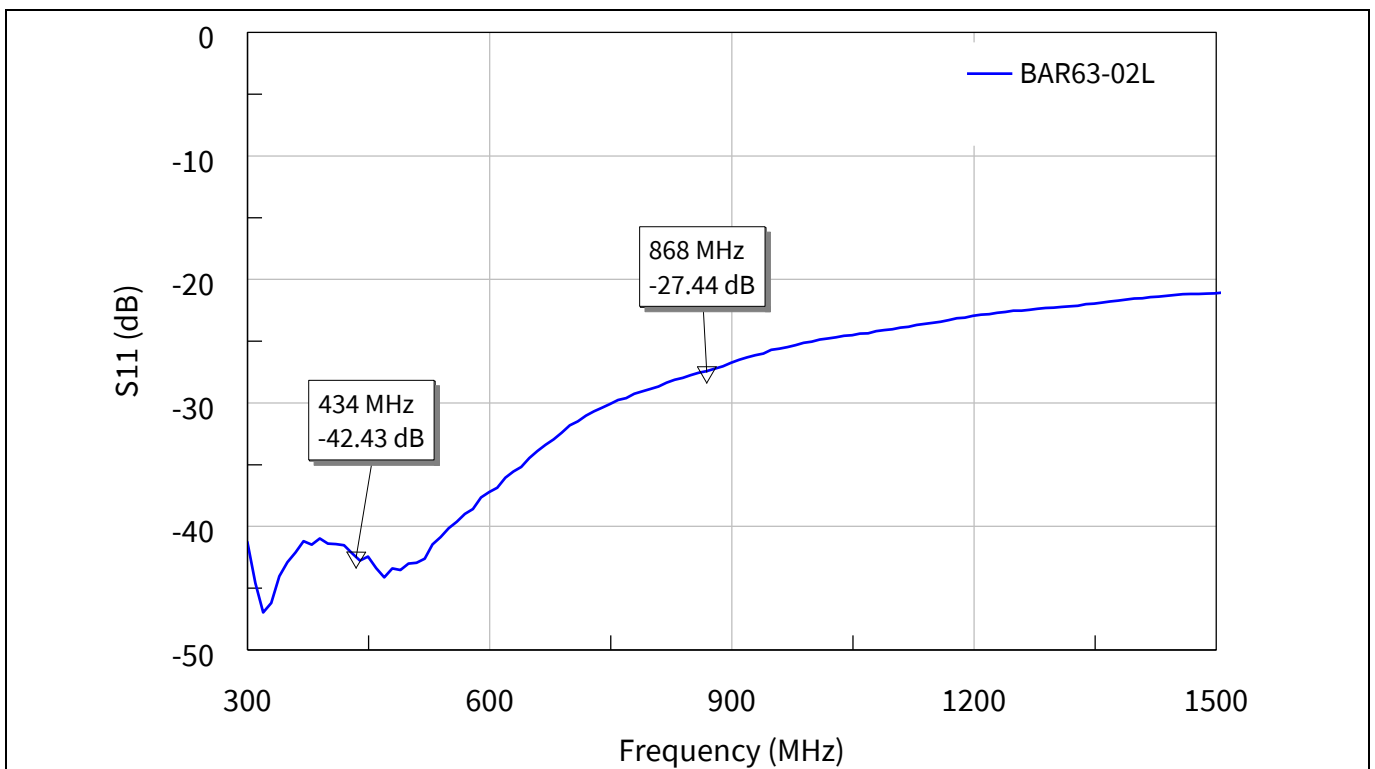

Figure 8 Input return loss of PIN diode SPST switch with [BAR63-02L](#) in on state ($I_{bias} = 9.8$ mA)

Note: The graphs are generated with the AWR electronic design automation (EDA) software Microwave Office®.

PIN diode SPST switches

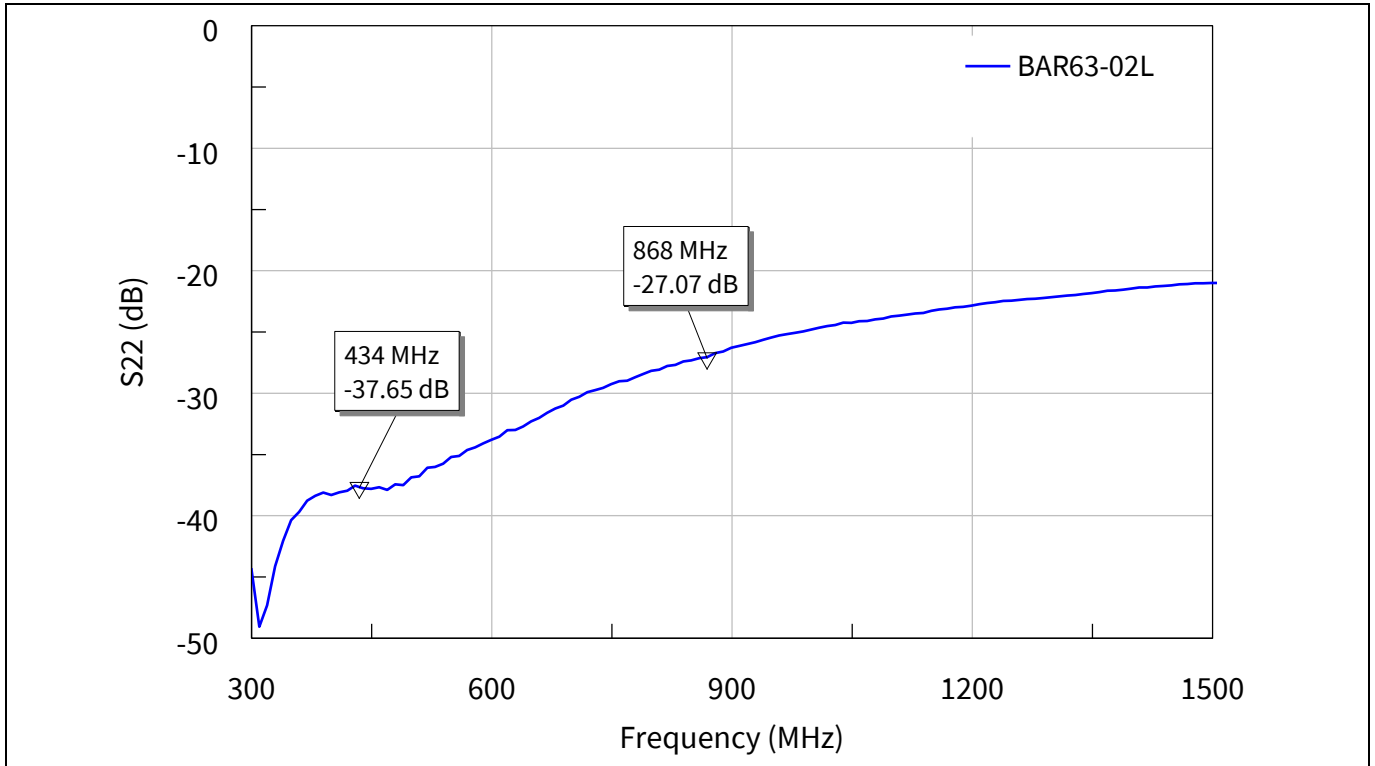

Figure 9 Output return loss of PIN diode SPST switch with [BAR63-02L](#) in on state ($I_{bias} = 9.8 \text{ mA}$)

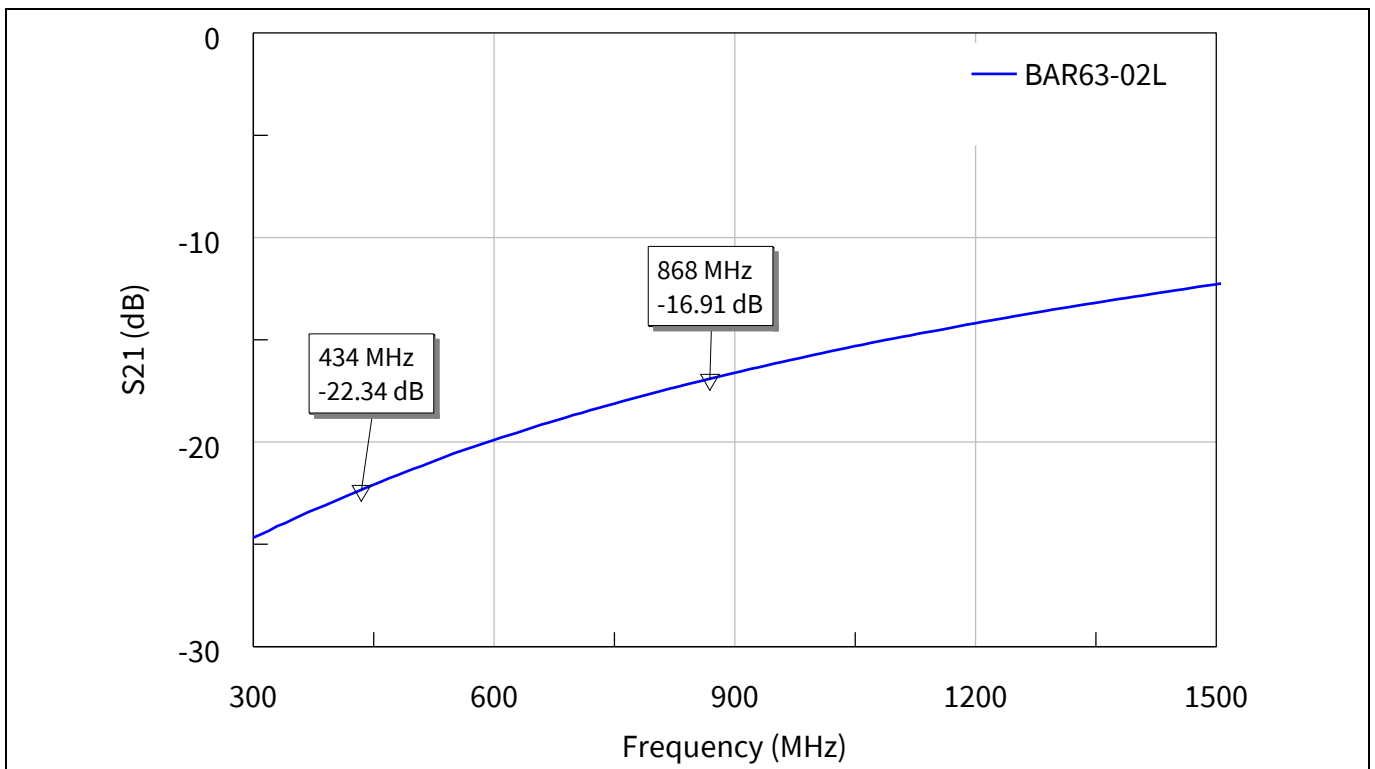

Figure 10 Isolation of PIN diode SPST switch with [BAR63-02L](#) in off state ($I_{bias} = 0 \text{ A}$)

PIN diode SPST switches

2.2 S-band range

2.2.1 Performance overview

The following table shows the SPST switch circuit performance with PIN diodes [BAR50-02V](#), [BAR64-02V](#) and [BAR90-02EL](#).

Table 4 Summary of measurement results of the SPST switch circuits

Parameter	Symbol	Value			Unit	Notes
Device		BAR50-02V	BAR64-02V	BAR90-02EL		
Bias voltage	V_{bias}	3.3	3.3	3.3	V	On state
Bias current	I_{bias}	10	10.1	10	mA	On state
Frequency	f	1.5 to 3.7	1.5 to 3.7	1.5 to 3.7	GHz	
Insertion loss (on state)	IL	0.33 ¹⁾ 0.35 ²⁾ 0.39 ³⁾	0.29 ¹⁾ 0.30 ²⁾ 0.37 ³⁾	0.21 ¹⁾ 0.22 ²⁾ 0.27 ³⁾	dB	SMA and PCB losses subtracted 1) Measured at 1.9 GHz (losses = 0.21 dB) 2) Measured at 2.4 GHz (losses = 0.27 dB) 3) Measured at 3.5 GHz (losses = 0.39 dB)
Input return loss	RL_{in}	>29	>20	>20	dB	
Output return loss	RL_{out}	>28	>19	>19.5	dB	
Isolation (off state)	ISO_{off}	16.8 ⁴⁾ 14.8 ⁵⁾ 11.9 ⁶⁾	15.6 ⁴⁾ 13.8 ⁵⁾ 10.5 ⁶⁾	13.9 ⁴⁾ 12.1 ⁵⁾ 9.1 ⁶⁾	dB	Off state ($I_{bias} = 0$ A) 4) Measured at 1.9 GHz 5) Measured at 2.4 GHz 6) Measured at 3.5 GHz
Input third order intercept point	IIP_3	> 45	> 45	> 45	dBm	Measured at $P_{IN} = 5$ dBm
Third order intermodulation distortion	IMD3	> 85	> 85	> 85	dBc	

2.2.2 Schematic

The following figure shows the schematic of the SPST switch. In the schematic, the resistor R1 is used to set the bias current. The inductor L2 provides the DC return path for the bias current. The capacitor C2 serves as the RF bypass. The input matching is achieved by the capacitor C1 and the inductor L1. The output matching network is formed by the capacitor C3 and the inductor L2.

PIN diode SPST switches

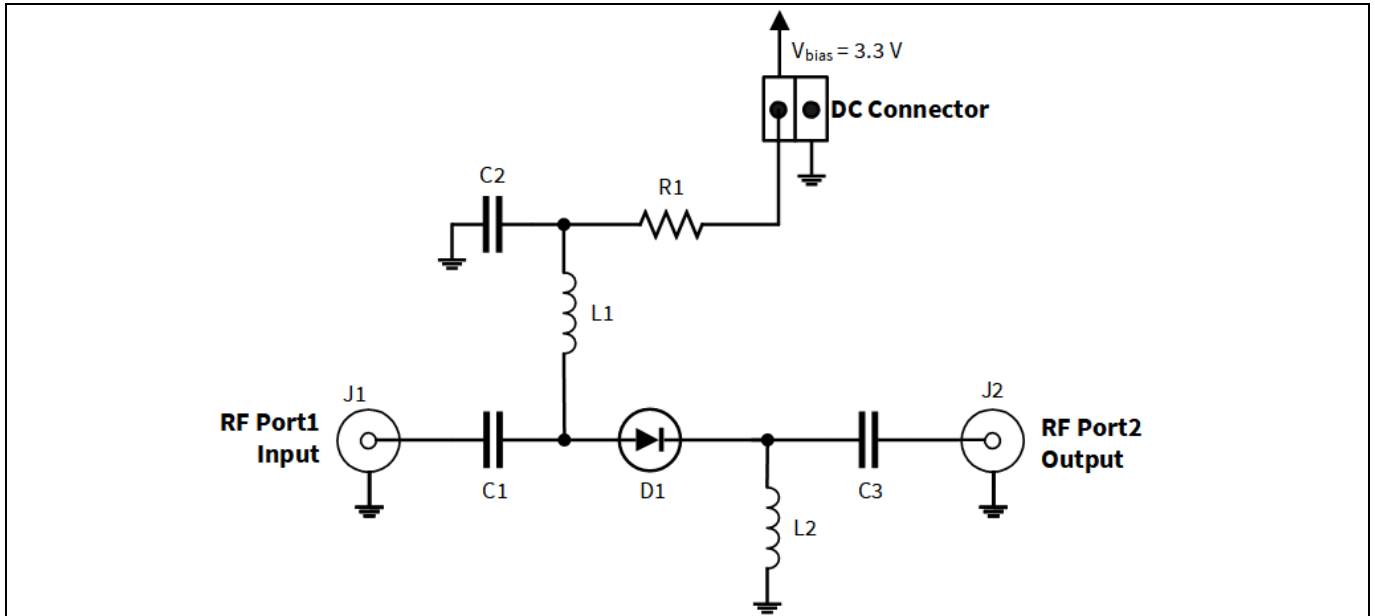

Figure 11 The SPST switch schematic

2.2.3 BOM

Table 5 BOM of the SPST switch circuits with [BAR50-02V](#), [BAR64-02V](#) and [BAR90-02EL](#)

Symbol	Value			Unit	Size	Manufacturer	Comment
D1	BAR50-02V (TSLP-2)	BAR64-02V (SC79)	BAR90-02EL (TSLP-2)	-	-	Infineon	PIN diode
C1	12	8.2	8.2	pF	0402	Various	DC block and input matching
C2	220	220	220	nF	0402	Various	RF bypass
C3	12	8.2	8.2	pF	0402	Various	DC block and output matching
L1	68	68	68	nH	0402	Murata LQW	RF choke
L2	68	68	68	nH	0402	Murata LQW	DC return
R1	240	240	240	Ω	0402	Various	DC bias

2.2.4 Evaluation board and layout information

The evaluation board information for the SPST switch circuit with [BAR50-02V](#), [BAR64-02V](#) and [BAR90-02EL](#):

- PCB material: FR4
- PCB marking: M180629 RF Diode 3

Images of the evaluation board and the PCB stack information are shown in the following figures.

PIN diode SPST switches

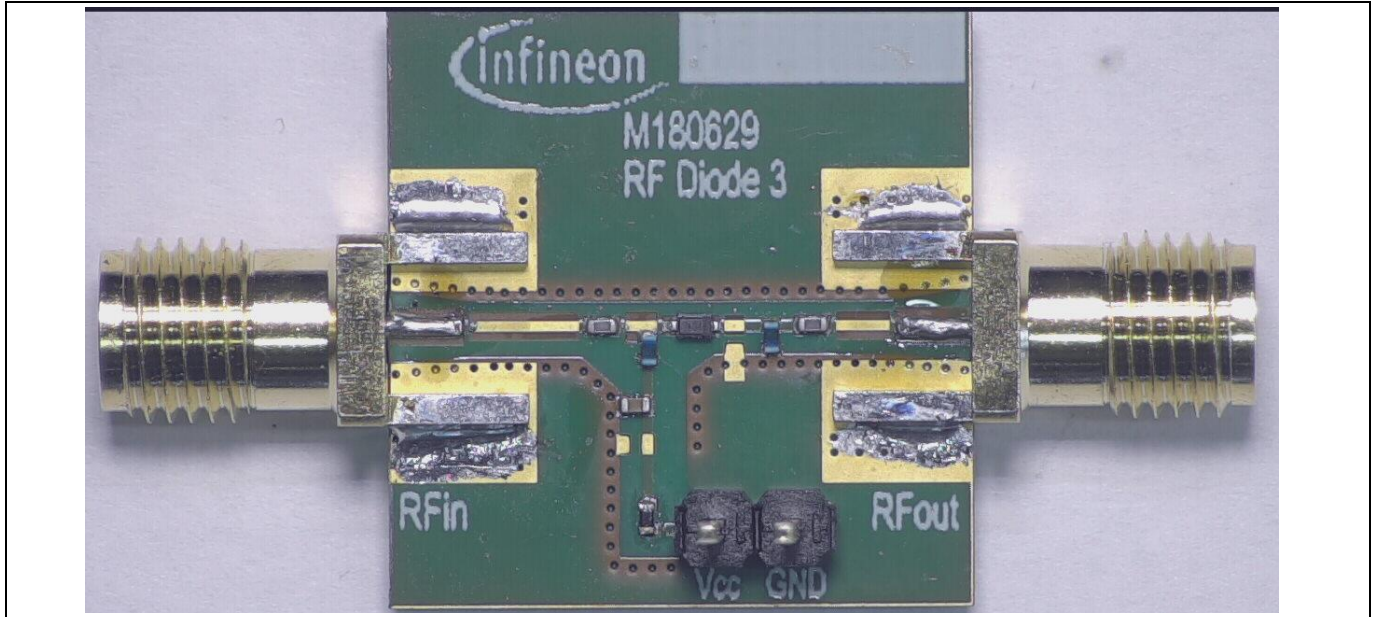

Figure 12 Photo of the evaluation board for PIN diode SPST switch with [BAR50-02V](#), [BAR64-02V](#) and [BAR90-02EL](#)

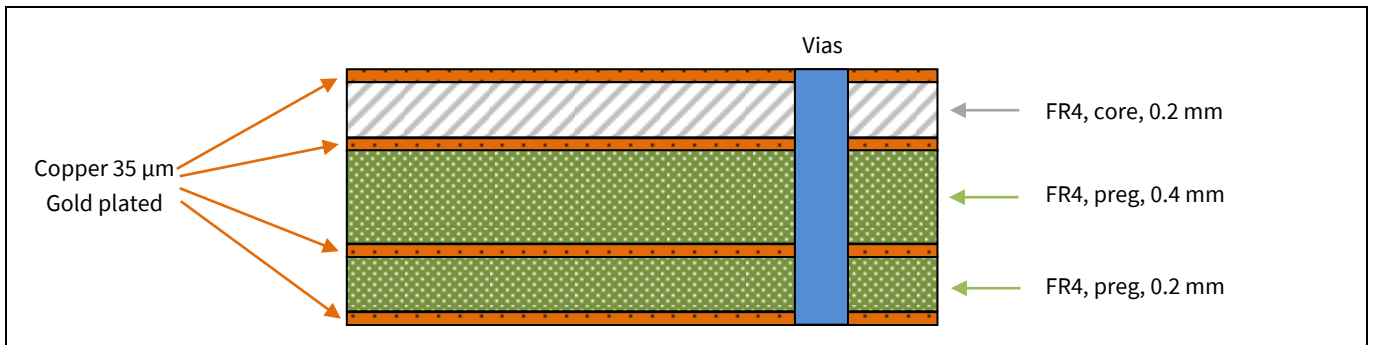

Figure 13 PCB stack information of the evaluation board for PIN diode SPST switch

PIN diode SPST switches

2.2.5 Measurement graphs

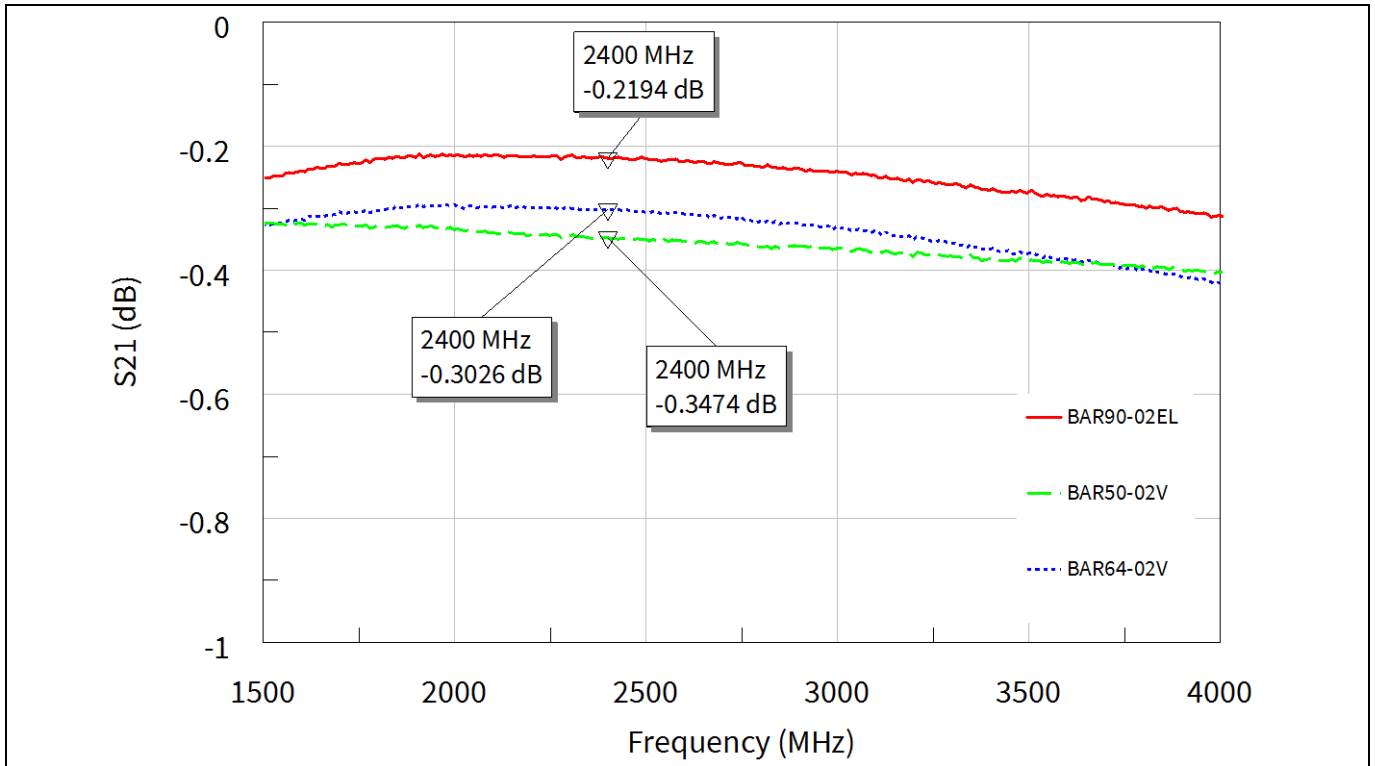

Figure 14 Insertion loss of PIN diode SPST switch with [BAR50-02V](#), [BAR64-02V](#) and [BAR90-02EL](#) in on state ($I_{bias} = 10 \text{ mA}$)

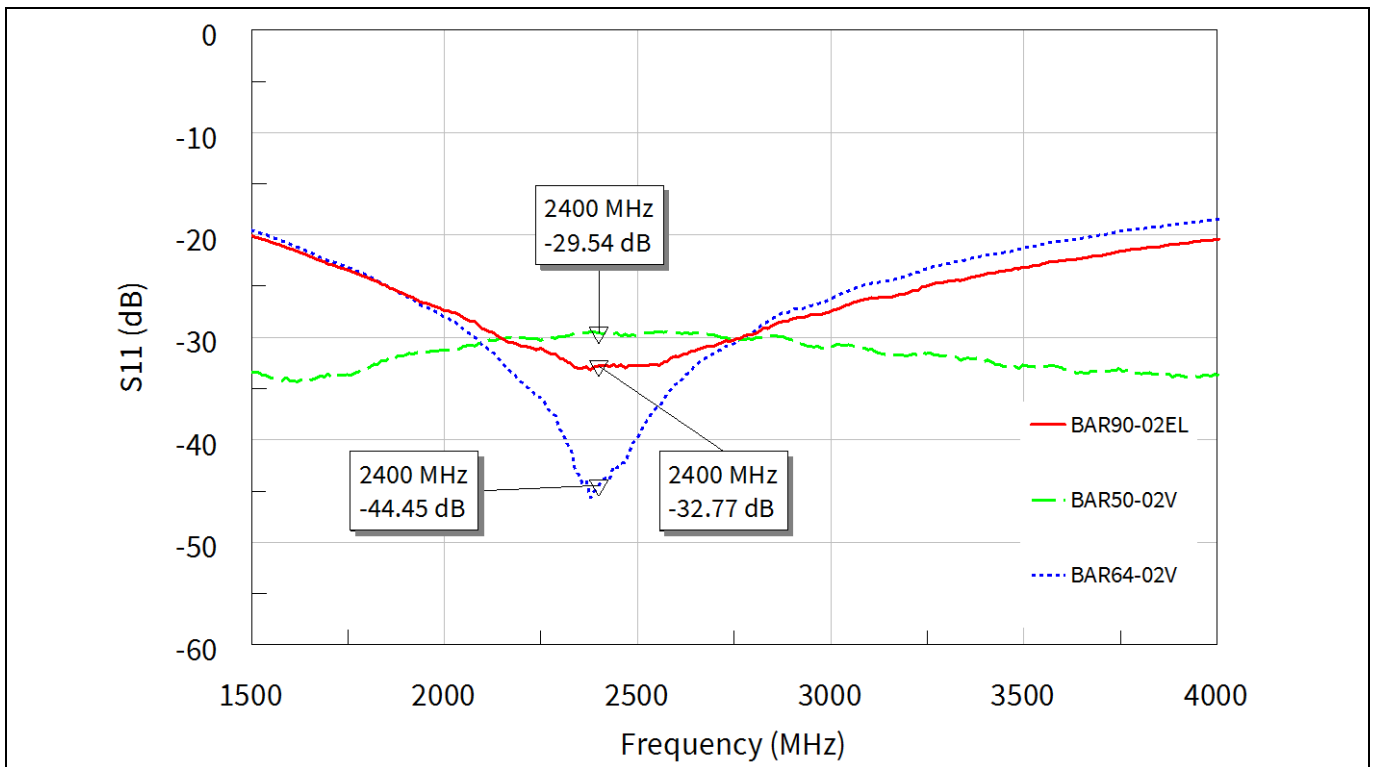

Figure 15 Input return loss of PIN diode SPST switch with [BAR50-02V](#), [BAR64-02V](#) and [BAR90-02EL](#) in on state ($I_{bias} = 10 \text{ mA}$)

PIN diode SPST switches

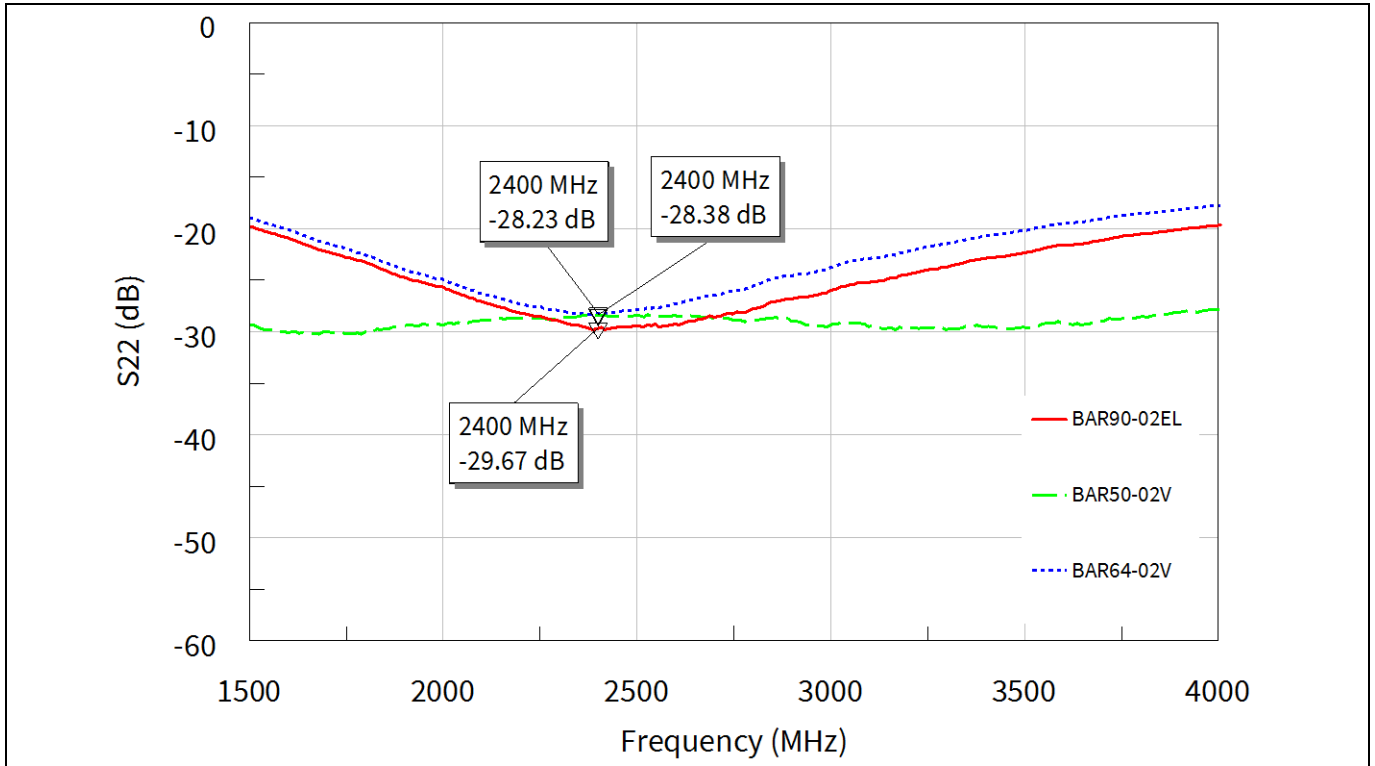

Figure 16 Output return loss of PIN diode SPST switch with [BAR50-02V](#), [BAR64-02V](#) and [BAR90-02EL](#) in on state ($I_{bias} = 10 \text{ mA}$)

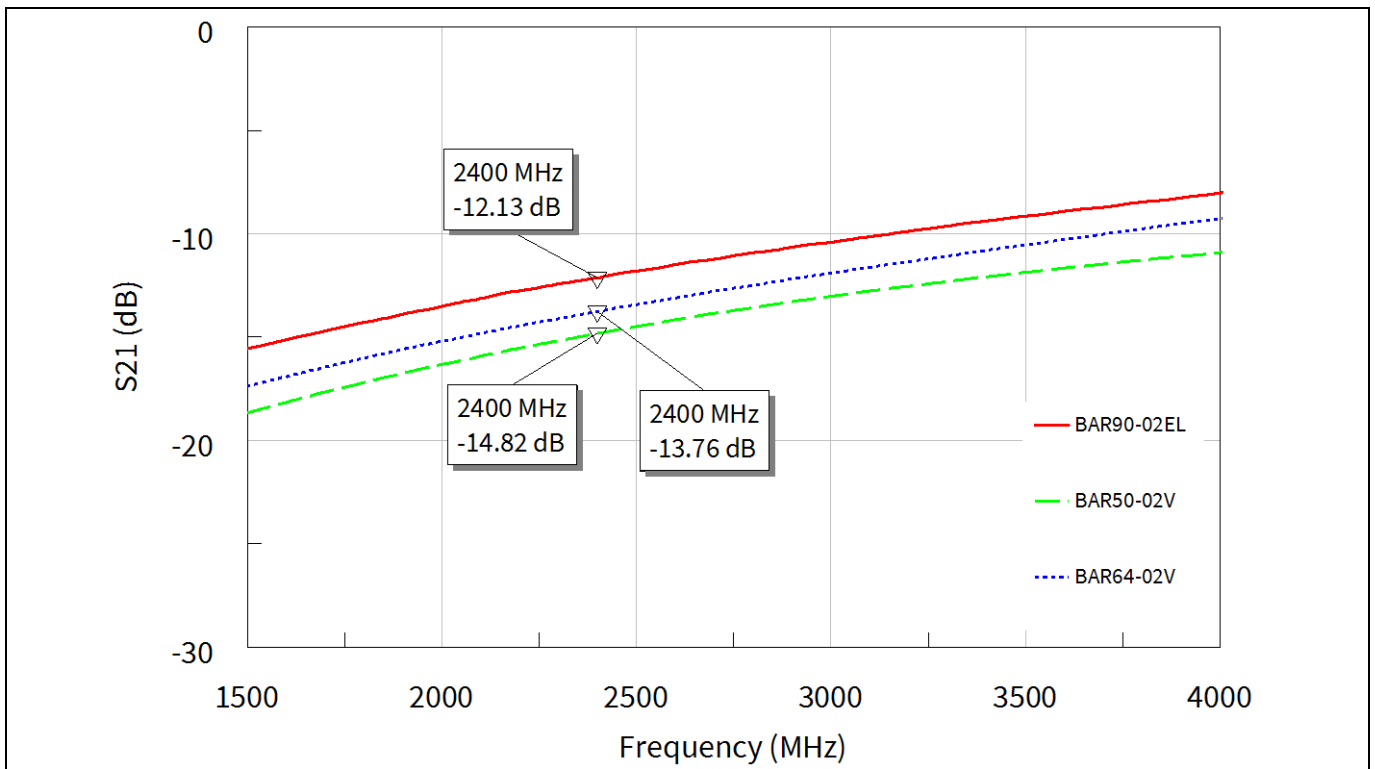

Figure 17 Isolation of PIN diode SPST switch with [BAR50-02V](#), [BAR64-02V](#) and [BAR90-02EL](#) in off state ($I_{bias} = 0 \text{ A}$)

PIN diode SPDT series switches

3 PIN diode SPDT series switches

3.1 Sub-GHz range

3.1.1 Performance overview

The following tables show the SPDT series switch performance with PIN diode [BAR63-02L](#).

Table 6 Summary of measurement results of the SPDT series switch circuit for ANT-Tx mode

Parameter	Symbol	Value	Unit	Notes
Device		BAR63-02L		
Bias voltage	V_{bias1}	3.3	V	Mode: ANT-Tx ($V_{bias2} = 0$ V)
Bias current	I_{bias1}	9.8	mA	Mode: ANT-Tx ($I_{bias2} = 0$ A)
Frequency	f	300 to 1000	MHz	
Input return loss	RL_{in}	>15.7	dB	
Output return loss	RL_{out}	>16.4	dB	
Insertion loss	IL	0.28 ¹⁾ 0.24 ²⁾ 0.32 ³⁾	dB	SMA and PCB losses subtracted 1) Measured at 315 MHz (losses = 0.05 dB) 2) Measured at 434 MHz (losses = 0.06 dB) 3) Measured at 868 MHz (losses = 0.12 dB)
Isolation Tx-Rx	ISO_{Tx-Rx}	30.5 ⁴⁾ 28.1 ⁵⁾ 22.1 ⁶⁾	dB	4) Measured at 315 MHz 5) Measured at 434 MHz 6) Measured at 868 MHz
Isolation ANT-Rx	ISO_{ANT-Rx}	29.7 ⁴⁾ 27.6 ⁵⁾ 21.9 ⁶⁾	dB	
Input third order intercept point	IIP_3	>45	dBm	Measured at $P_{IN} = 5$ dBm
Third order intermodulation distortion	IMD3	>85	dBc	

PIN diode SPDT series switches

Table 7 Summary of measurement results of the SPDT series switch circuit for ANT-Rx mode

Parameter	Symbol	Value	Unit	Notes
Device		BAR63-02L		
Bias voltage	V_{bias2}	3.3	V	Mode: ANT-Rx ($V_{bias1} = 0$ V)
Bias current	I_{bias2}	9.7	mA	Mode: ANT-Rx ($I_{bias1} = 0$ A)
Frequency	f	300 to 1000	MHz	
Input return loss	RL_{in}	>15.2	dB	
Output return loss	RL_{out}	>16.6	dB	
Insertion loss	IL	0.28 ¹⁾ 0.25 ²⁾ 0.36 ³⁾	dB	SMA and PCB losses subtracted 1) Measured at 315 MHz (losses = 0.05 dB) 2) Measured at 434 MHz (losses = 0.06 dB) 3) Measured at 868 MHz (losses = 0.12 dB)
Isolation Tx-Rx	ISO_{Tx-Rx}	28.5 ⁴⁾ 26.1 ⁵⁾ 20.7 ⁶⁾	dB	4) Measured at 315 MHz 5) Measured at 434 MHz 6) Measured at 868 MHz
Isolation ANT-Tx	ISO_{ANT-Tx}	27.8 ⁴⁾ 25.6 ⁵⁾ 20.4 ⁶⁾	dB	
Input third order intercept point	IIP_3	>45	dBm	Measured at $P_{IN} = 5$ dBm
Third order intermodulation distortion	IMD3	>85	dBc	

3.1.2 Schematic

The following figure shows the schematic of the SPDT series switch. In the schematic, each branch of the switch contains one series connected PIN diode. The resistors R1 and R2 are used to set the bias current for each branch of the switch respectively. The inductors L1 and L4 provide the DC return path for the bias current. The capacitors C2 and C5 serve as the RF bypass. The capacitors C3 and C4 provide the DC block and the matching at the common input port. The matching network at the output port one is formed by the capacitor C1 and the inductor L1, and the matching network at output two is formed by the capacitor C6 and the inductor L4.

PIN diode SPDT series switches

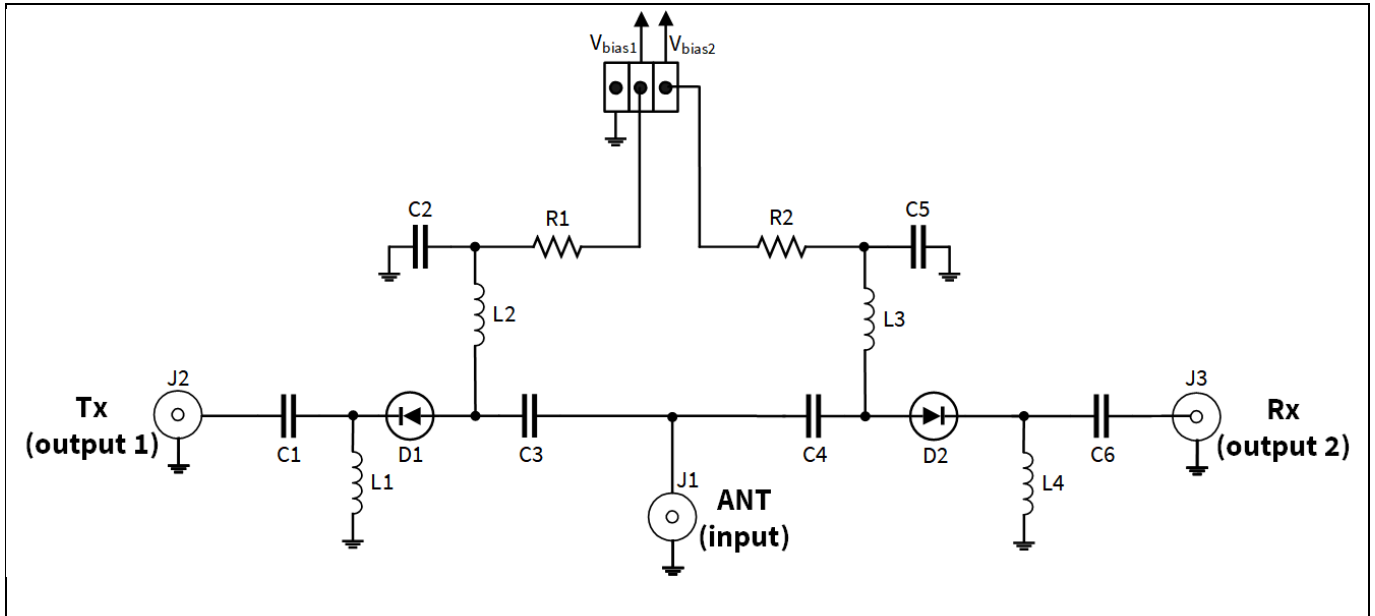

Figure 18 The SPDT series switch schematic

3.1.3 BOM

Table 8 BOM of the SPDT series switch circuit with [BAR63-02L](#)

Symbol	Value	Unit	Size	Manufacturer	Comment
D1, D2	BAR63-02L	-	TSLP-2	Infineon	PIN diode
C1	33	pF	0402	Various	DC block and Tx matching
C2	220	nF	0402	Various	RF bypass
C3	33	pF	0402	Various	DC block and input matching
C4	33	pF	0402	Various	DC block and input matching
C5	220	nF	0402	Various	RF bypass
C6	33	pF	0402	Various	DC block and Rx matching
L1	150	nH	0402	Murata LQG	DC return, Tx branch
L2	150	nH	0402	Murata LQG	RF choke
L3	150	nH	0402	Murata LQG	RF choke
L4	150	nH	0402	Murata LQG	DC return, Rx branch
R1	240	Ω	0402	Various	DC bias
R2	240	Ω	0402	Various	DC bias

PIN diode SPDT series switches

3.1.4 Evaluation board and layout information

The evaluation board information for the SPDT switch circuit with [BAR63-02L](#):

- PCB material: FR4
- PCB marking: M180629 RF Diode 4

Images of the evaluation board and the PCB stack information are shown in the following figures.

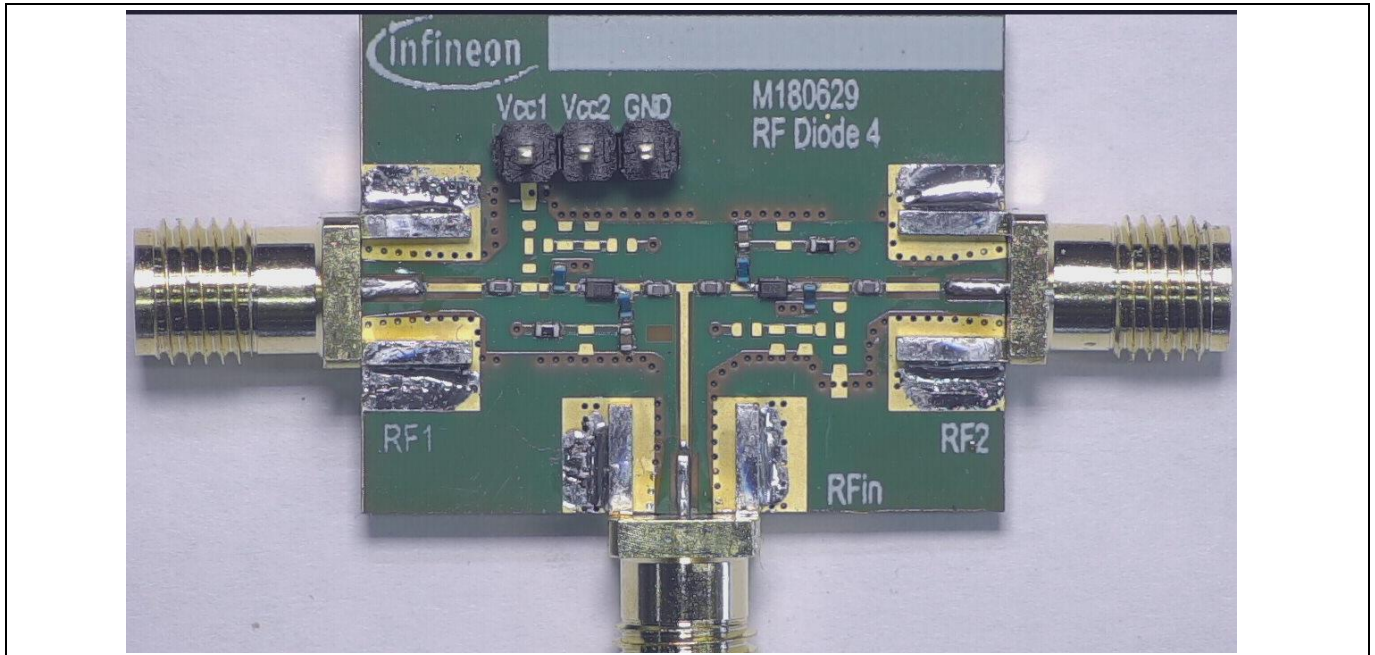

Figure 19 Photo of the evaluation board for PIN diode SPDT switch with [BAR63-02L](#)

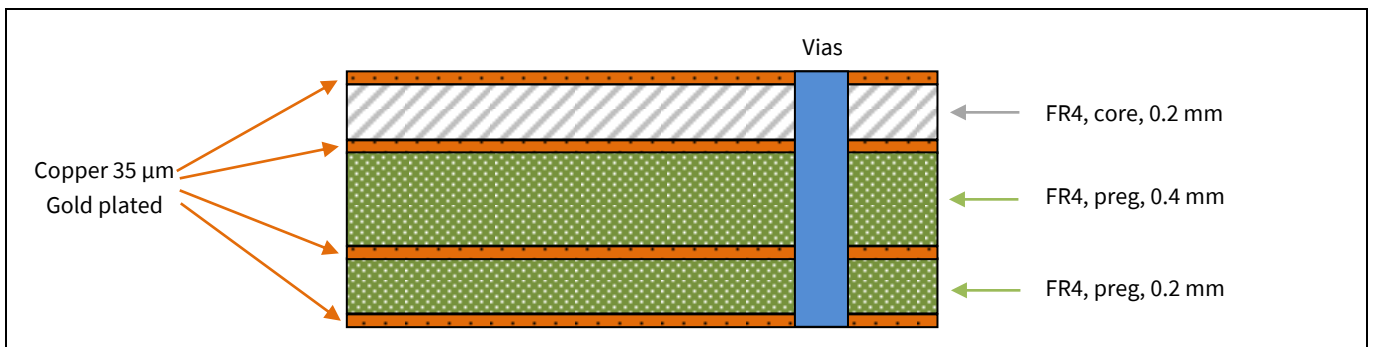

Figure 20 PCB stack information of the evaluation board for PIN diode SPDT switch

PIN diode SPDT series switches

3.1.5 Measurement graphs

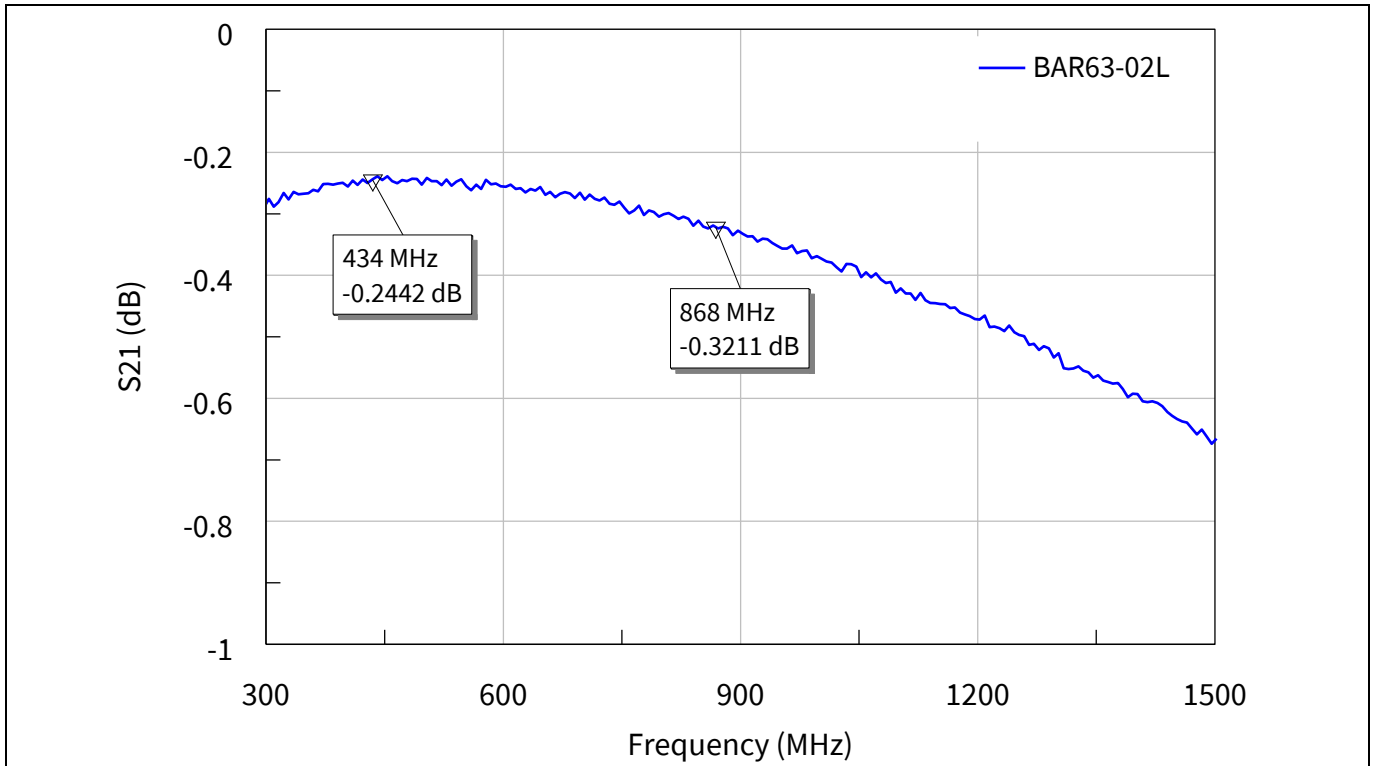

Figure 21 Insertion loss of the SPDT series switch with [BAR63-02L](#) in ANT-Tx mode ($I_{bias1} = 9.8 \text{ mA}$)

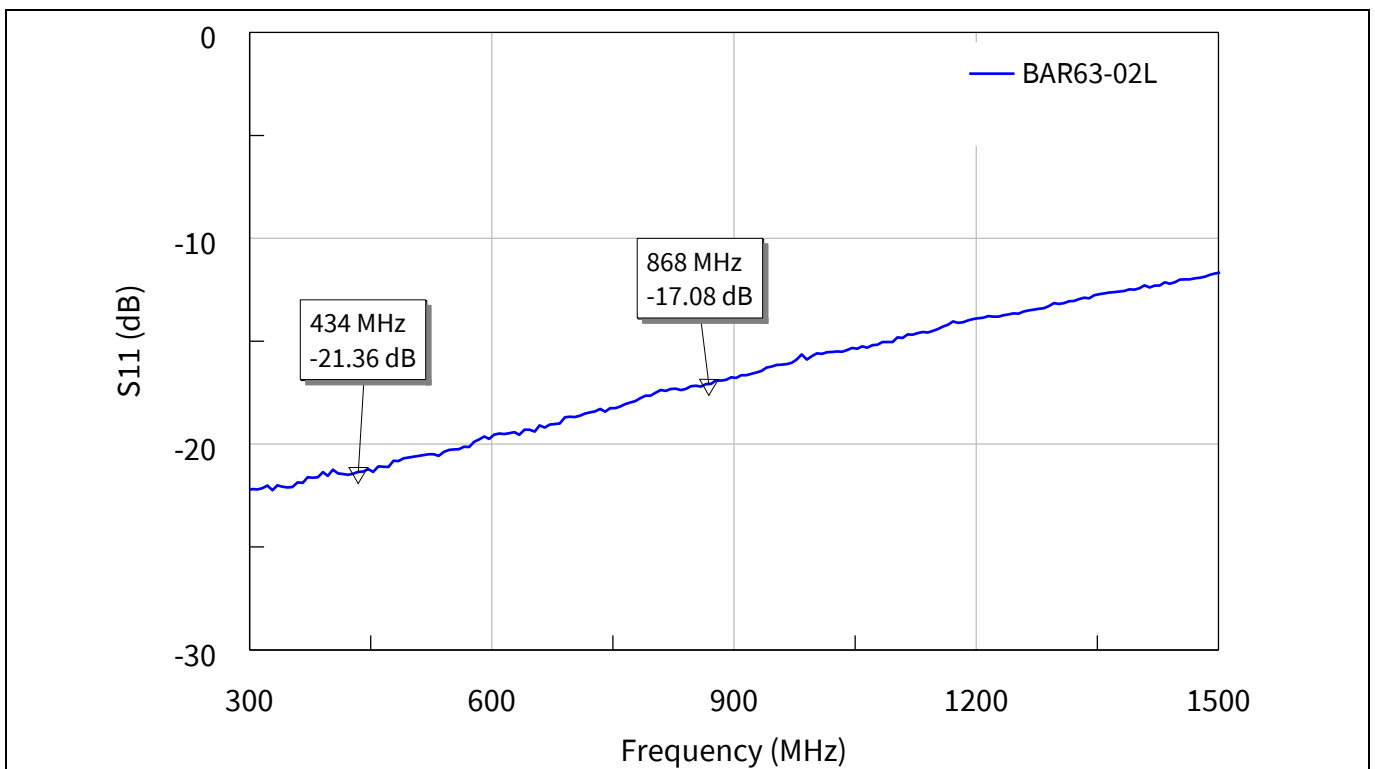

Figure 22 Input return loss of the SPDT series switch with [BAR63-02L](#) in ANT-Tx mode ($I_{bias1} = 9.8 \text{ mA}$)

PIN diode SPDT series switches

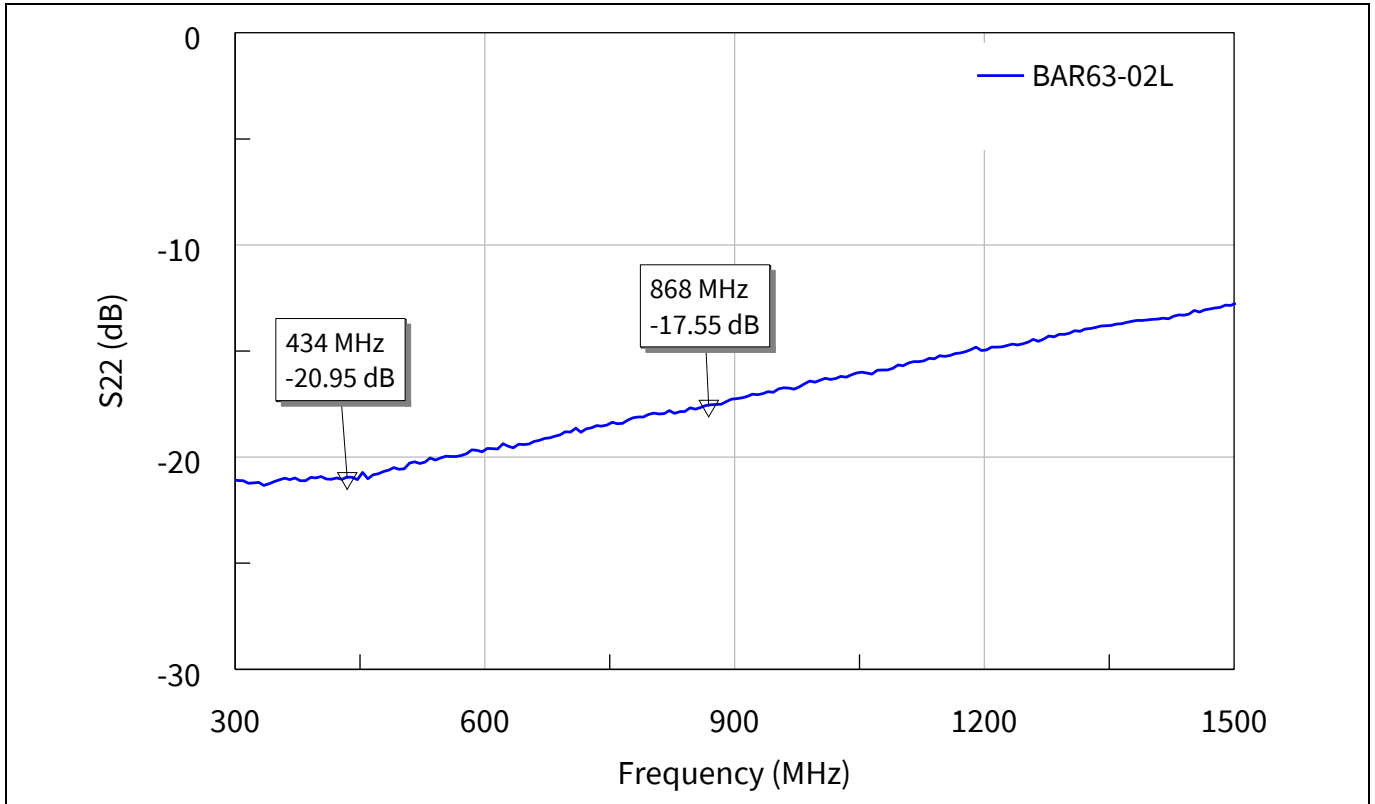

Figure 23 Output return loss of the SPDT series switch with [BAR63-02L](#) in ANT-Tx mode ($I_{bias1} = 9.8 \text{ mA}$)

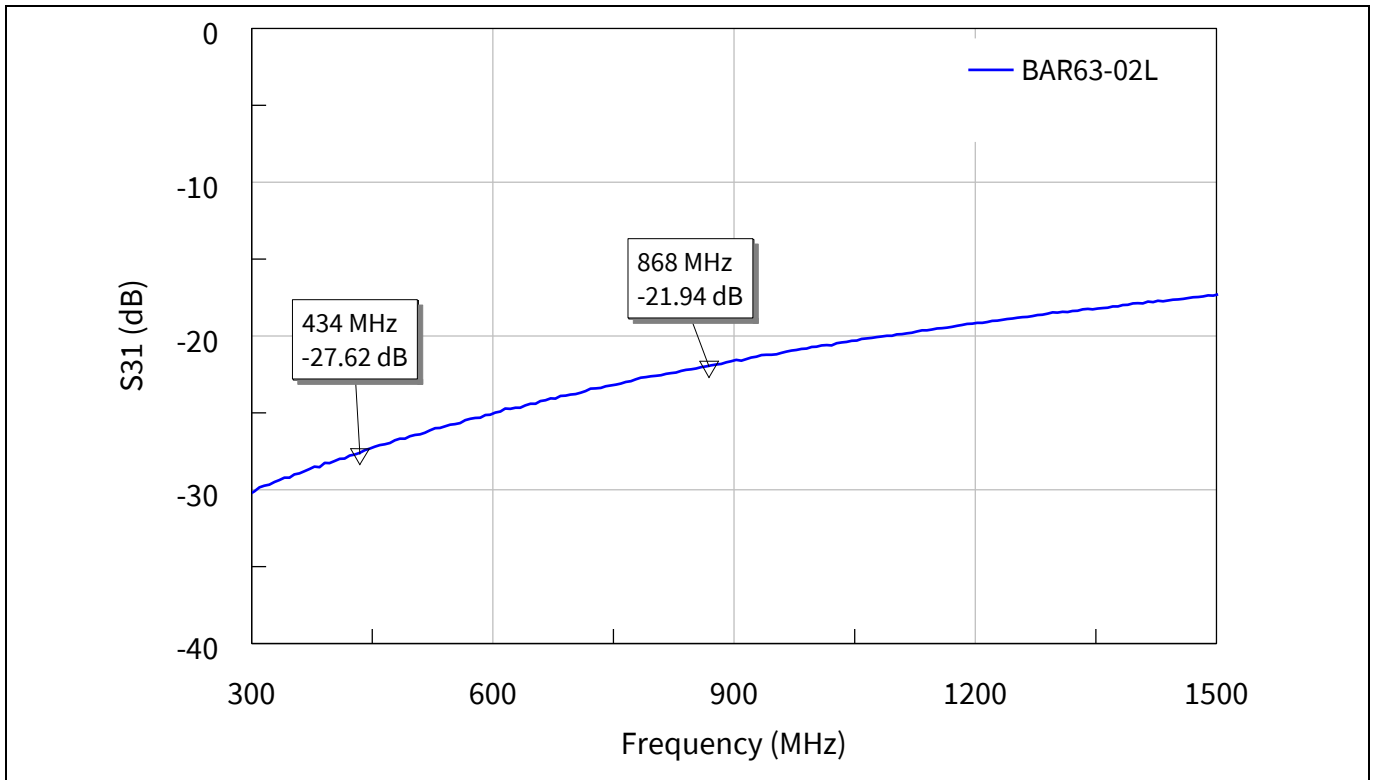

Figure 24 ANT-Rx isolation of the SPDT series switch with [BAR63-02L](#) in ANT-Tx mode ($I_{bias1} = 9.8 \text{ mA}$)

PIN diode SPDT series switches

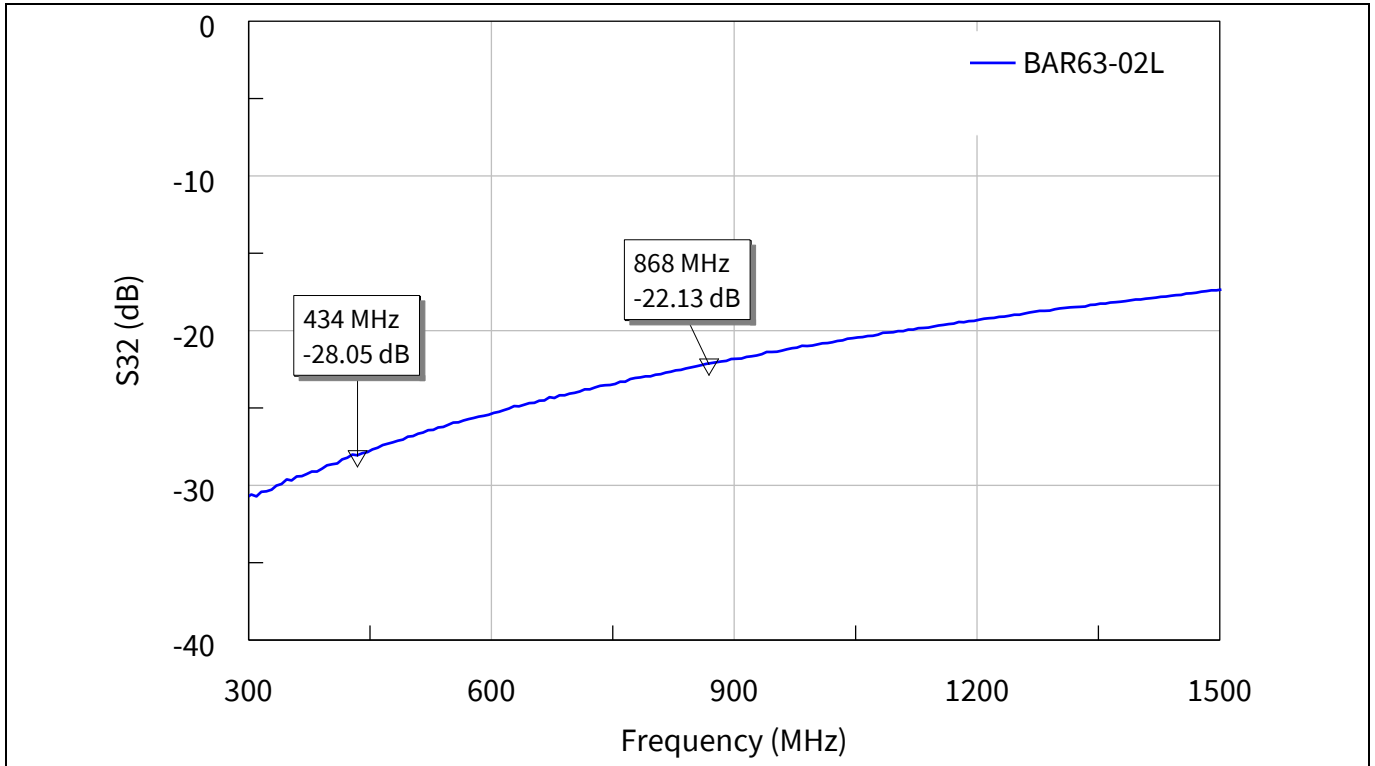

Figure 25 Tx-Rx isolation of the SPDT series switch with [BAR63-02L](#) in ANT-Tx mode ($I_{bias1} = 9.8 \text{ mA}$)

PIN diode SPDT series switches

3.2 S-band range

3.2.1 Performance overview

The following tables show the SPDT series switch performance with PIN diodes [BAR50-02V](#), [BAR64-02V](#) and [BAR90-02EL](#).

Table 9 Summary of measurement results of the SPDT series switch circuits for ANT-Tx mode

Parameter	Symbol	Value			Unit	Notes
Device		BAR50-02V	BAR64-02V	BAR90-02EL		
Bias voltage	V_{bias1}	3.3	3.3	3.3	V	Mode: ANT-Tx ($V_{bias2} = 0$ V)
Bias current	I_{bias1}	10	10.1	10.1	mA	Mode: ANT-Tx ($I_{bias2} = 0$ A)
Frequency	f	1.5 to 3.7	1.5 to 3.7	1.5 to 3.7	GHz	
Input return loss	RL_{in}	>8.4	>10.1	>10.6	dB	
Output return loss	RL_{out}	>9.9	>11.8	>11.8	dB	
Insertion loss	IL	0.74 ¹⁾ 0.64 ²⁾ 1.20 ³⁾	0.67 ¹⁾ 0.67 ²⁾ 0.96 ³⁾	0.67 ¹⁾ 0.72 ²⁾ 0.90 ³⁾	dB	SMA and PCB losses subtracted 1) Measured at 1.9 GHz (losses = 0.27 dB) 2) Measured at 2.4 GHz (losses = 0.36 dB) 3) Measured at 3.5 GHz (losses = 0.50 dB)
Isolation Tx-Rx	ISO_{Tx-Rx}	19.9 ⁴⁾ 18.3 ⁵⁾ 14.9 ⁶⁾	18.2 ⁴⁾ 18.1 ⁵⁾ 15.2 ⁶⁾	16.7 ⁴⁾ 17.8 ⁵⁾ 15.8 ⁶⁾	dB	4) Measured at 1.9 GHz 5) Measured at 2.4 GHz 6) Measured at 3.5 GHz
Isolation ANT-Rx	ISO_{ANT-Rx}	19.9 ⁴⁾ 18.3 ⁵⁾ 14.8 ⁶⁾	18.2 ⁴⁾ 18.1 ⁵⁾ 15.2 ⁶⁾	16.7 ⁴⁾ 17.8 ⁵⁾ 15.8 ⁶⁾	dB	
Input third order intercept point	IIP_3	>45	>45	>45	dBm	Measured at $P_{IN} = 5$ dBm
Third order intermodulation distortion	IMD3	>85	>85	>85	dBc	

PIN diode SPDT series switches

Table 10 Summary of measurement results of the SPDT series switch circuits for ANT-Rx mode

Parameter	Symbol	Value			Unit	Notes
Device		BAR50-02V	BAR64-02V	BAR90-02EL		
Bias voltage	V_{bias2}	3.3	3.3	3.3	V	Mode: ANT-Rx ($V_{bias1} = 0$ V)
Bias current	I_{bias2}	10	10	10.1	mA	Mode: ANT-Rx ($I_{bias1} = 0$ A)
Frequency	f	1.5 to 3.7	1.5 to 3.7	1.5 to 3.7	GHz	
Input return loss	RL_{in}	>8	>9.2	>10.7	dB	
Output return loss	RL_{out}	>9.1	>10.8	>11.2	dB	
Insertion loss	IL	0.77 ¹⁾ 0.58 ²⁾ 1.07 ³⁾	0.72 ¹⁾ 0.62 ²⁾ 1.0 ³⁾	0.68 ¹⁾ 0.67 ²⁾ 0.87 ³⁾	dB	SMA and PCB losses subtracted 1) Measured at 1.9 GHz (losses = 0.27 dB) 2) Measured at 2.4 GHz (losses = 0.36 dB) 3) Measured at 3.5 GHz (losses = 0.50 dB)
Isolation Tx-Rx	ISO_{Tx-Rx}	21.5 ⁴⁾ 19.9 ⁵⁾ 16.4 ⁶⁾	17.6 ⁴⁾ 17.4 ⁵⁾ 14.4 ⁶⁾	16.7 ⁴⁾ 17.8 ⁵⁾ 15.7 ⁶⁾	dB	4) Measured at 1.9 GHz 5) Measured at 2.4 GHz 6) Measured at 3.5 GHz
Isolation ANT-Tx	ISO_{ANT-Tx}	21.8 ⁴⁾ 20.2 ⁵⁾ 16.8 ⁶⁾	17.7 ⁴⁾ 17.5 ⁵⁾ 14.6 ⁶⁾	17.6 ⁴⁾ 18.0 ⁵⁾ 15.1 ⁶⁾	dB	
Input third order intercept point	IIP_3	>45	>45	>45	dBm	Measured at $P_{IN} = 5$ dBm
Third order intermodulation distortion	IMD3	>85	>85	>85	dBc	

3.2.2 Schematic

The following figure shows the schematic of the SPDT series switch. In the schematic, each branch of the switch contains one series-connected PIN diode. The resistors R1 and R2 are used to set the bias current for the branch one and the branch two of the switch respectively. The inductors L1 and L4 provide the DC return path for the bias current. The capacitors C2 and C5 serve as the RF bypass. The capacitors C3 and C4 provide the DC block and the matching at the common input port. The matching network at output port one is formed by the capacitor C1 and the inductor L1, and the matching network at output two is formed by the capacitor C6 and the inductor L4.

PIN diode SPDT series switches

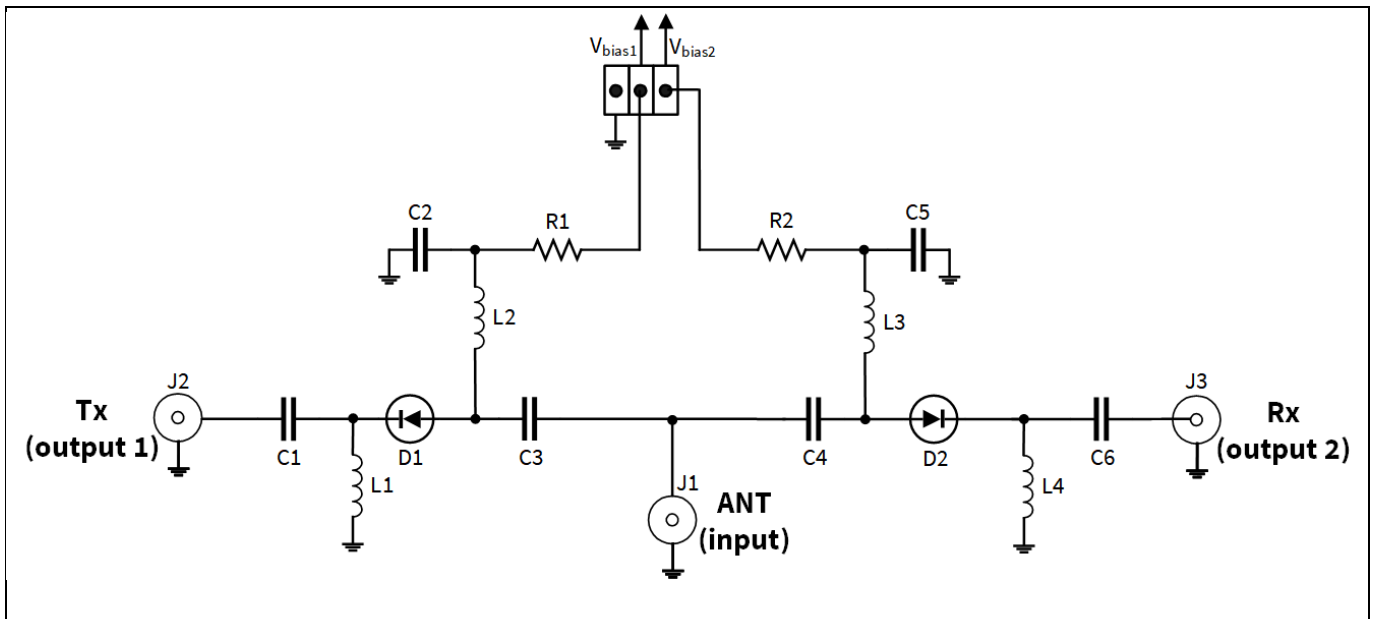

Figure 26 The SPDT series switch schematic

3.2.3 BOM

Table 11 BOM of the SPDT series switch circuits with [BAR50-02V](#), [BAR64-02V](#) and [BAR90-02EL](#)

Symbol	Value			Unit	Size	Manufacturer	Comment
D1, D2	BAR50-02V (SC79)	BAR64-02V (SC79)	BAR90-02EL (TSLP-2)	-	-	Infineon	PIN diode
C1	2.7	2.2	1.8	pF	0402	Various	DC block and Tx matching
C2	220	220	220	nF	0402	Various	RF bypass
C3	3.9	2.2	1.8	pF	0402	Various	DC block and input matching
C4	3.9	2.2	1.8	pF	0402	Various	DC block and input matching
C5	220	220	220	nF	0402	Various	RF bypass
C6	2.7	2.2	1.8	pF	0402	Various	DC block and Rx matching
L1	7.5	6.8	6.8	nH	0402	Murata LQG	DC return, Tx branch
L2	7.5	6.8	6.8	nH	0402	Murata LQG	RF choke
L3	7.5	6.8	6.8	nH	0402	Murata LQG	RF choke
L4	7.5	6.8	6.8	nH	0402	Murata LQG	DC return, Rx branch
R1	240	240	240	Ω	0402	Various	DC bias
R2	240	240	240	Ω	0402	Various	DC bias

PIN diode SPDT series switches

3.2.4 Evaluation board and layout information

The evaluation board information for the SPST switch circuit with [BAR50-02V](#), [BAR64-02V](#) and [BAR90-02EL](#):

- PCB material: FR4
- PCB marking: M180629 RF Diode 4

Images of the evaluation board and the PCB stack information are shown in the following figures.

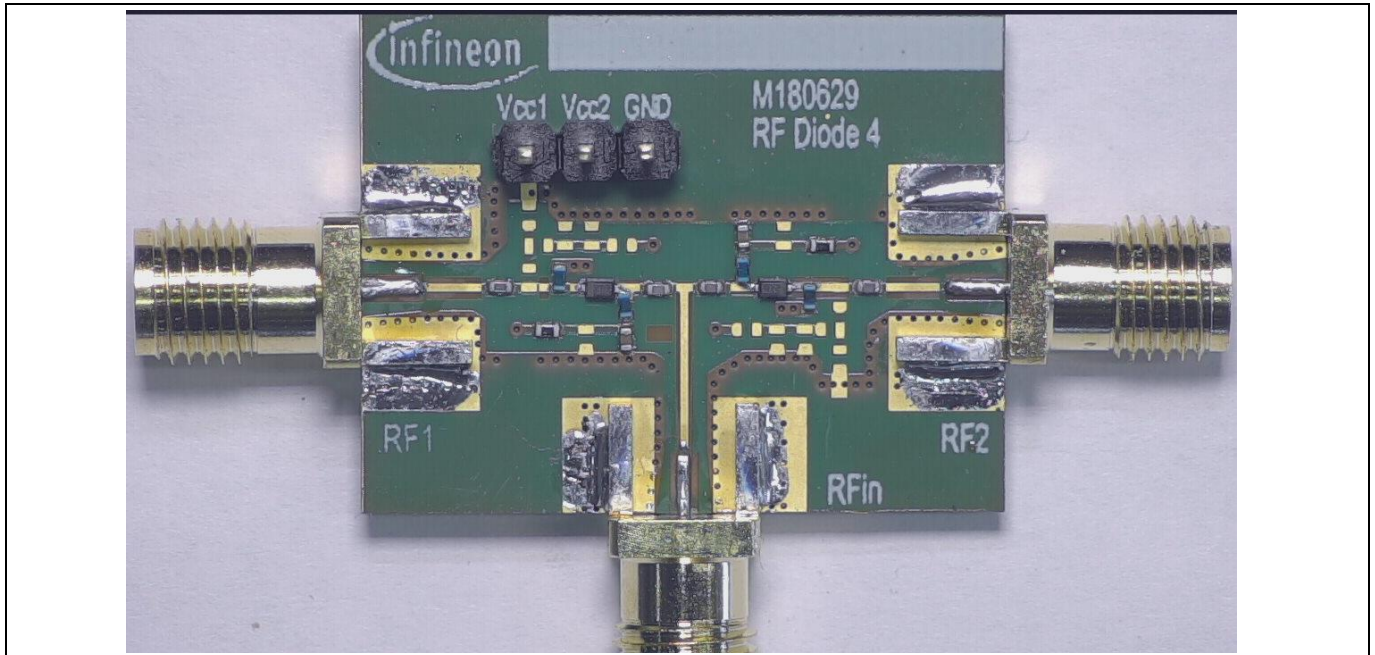

Figure 27 Photo of the evaluation board for the PIN diode SPDT switch with [BAR50-02V](#), [BAR64-02V](#) and [BAR90-02EL](#)

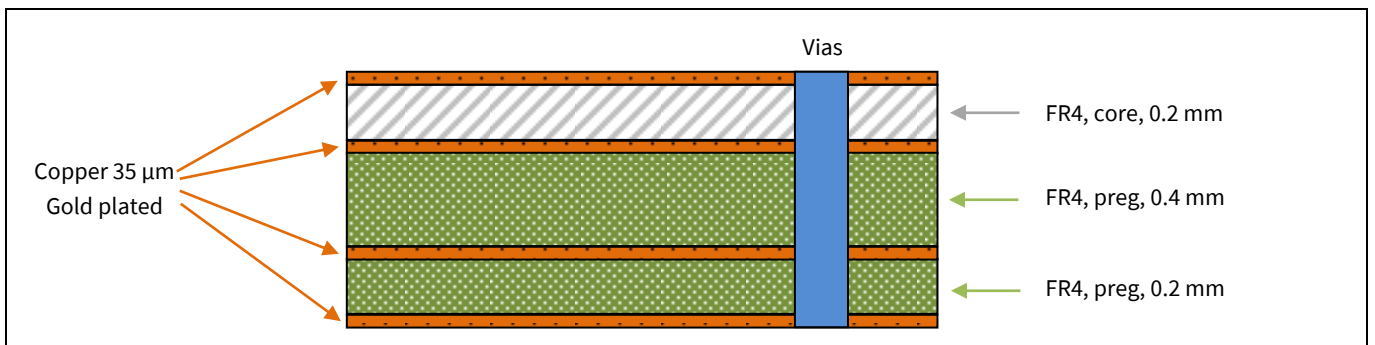

Figure 28 PCB stack information of the evaluation board for the PIN diode SPDT switch

PIN diode SPDT series switches

3.2.5 Measurement graphs

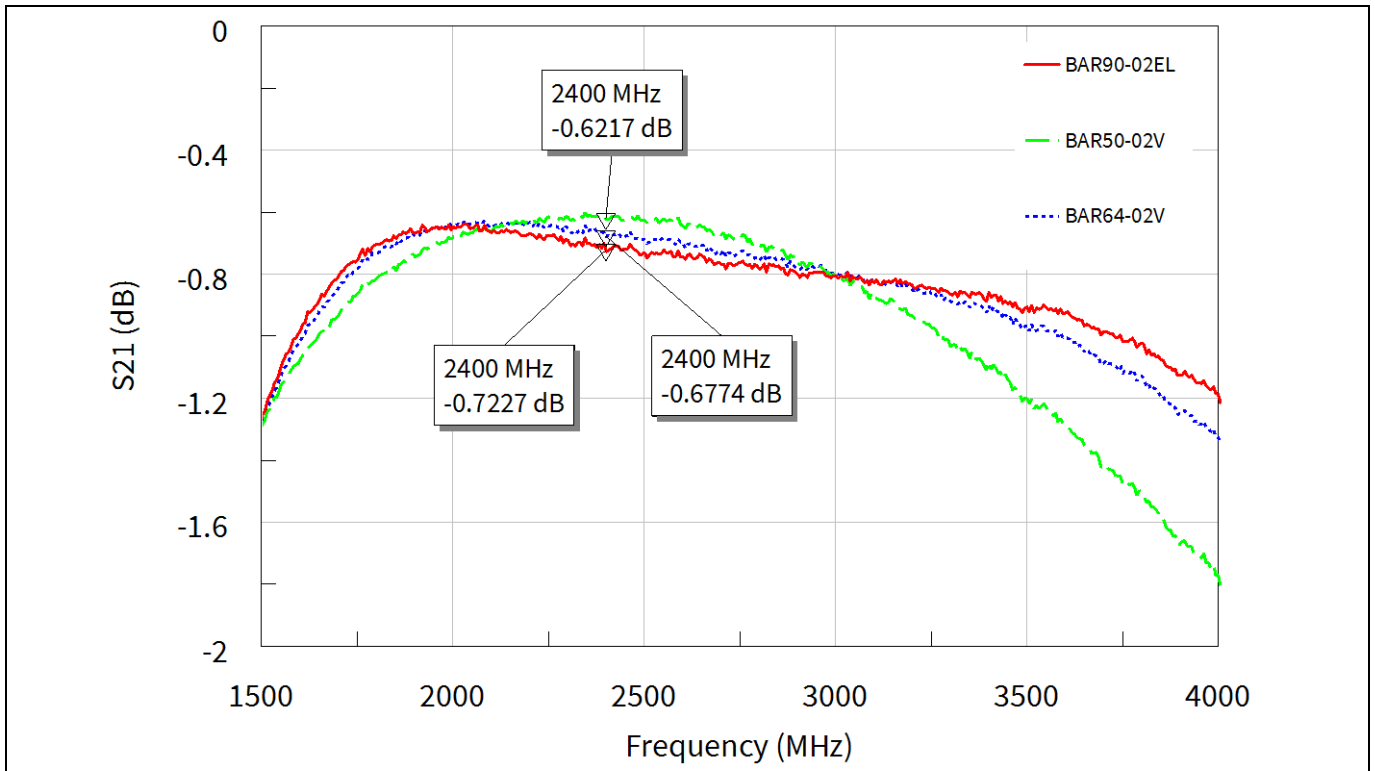

Figure 29 Insertion loss of the SPDT series switch with [BAR50-02V](#), [BAR64-02V](#) and [BAR90-02EL](#) in ANT-Tx mode ($I_{bias1} = 10 \text{ mA}$)

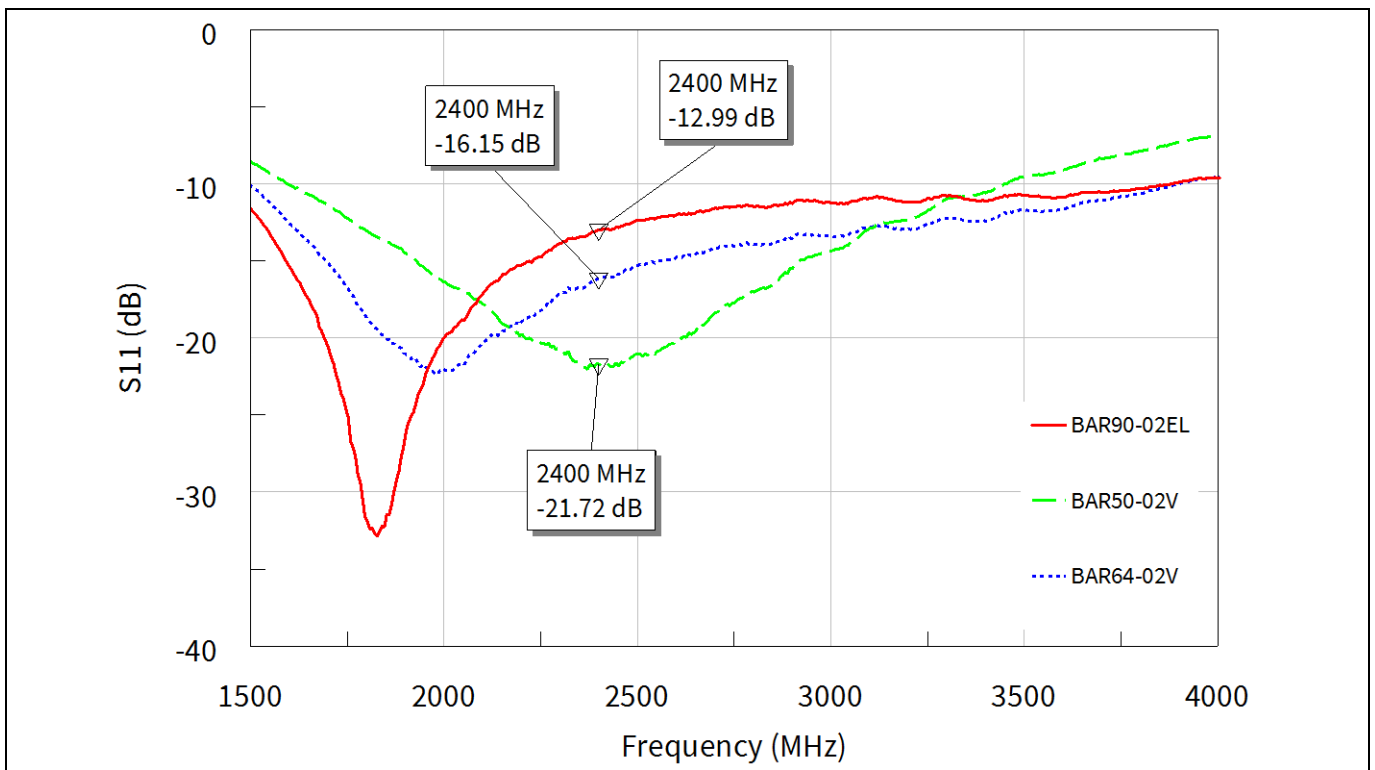

Figure 30 Input return loss of the SPDT series switch with [BAR50-02V](#), [BAR64-02V](#) and [BAR90-02EL](#) in ANT-Tx mode ($I_{bias1} = 10 \text{ mA}$)

PIN diode SPDT series switches

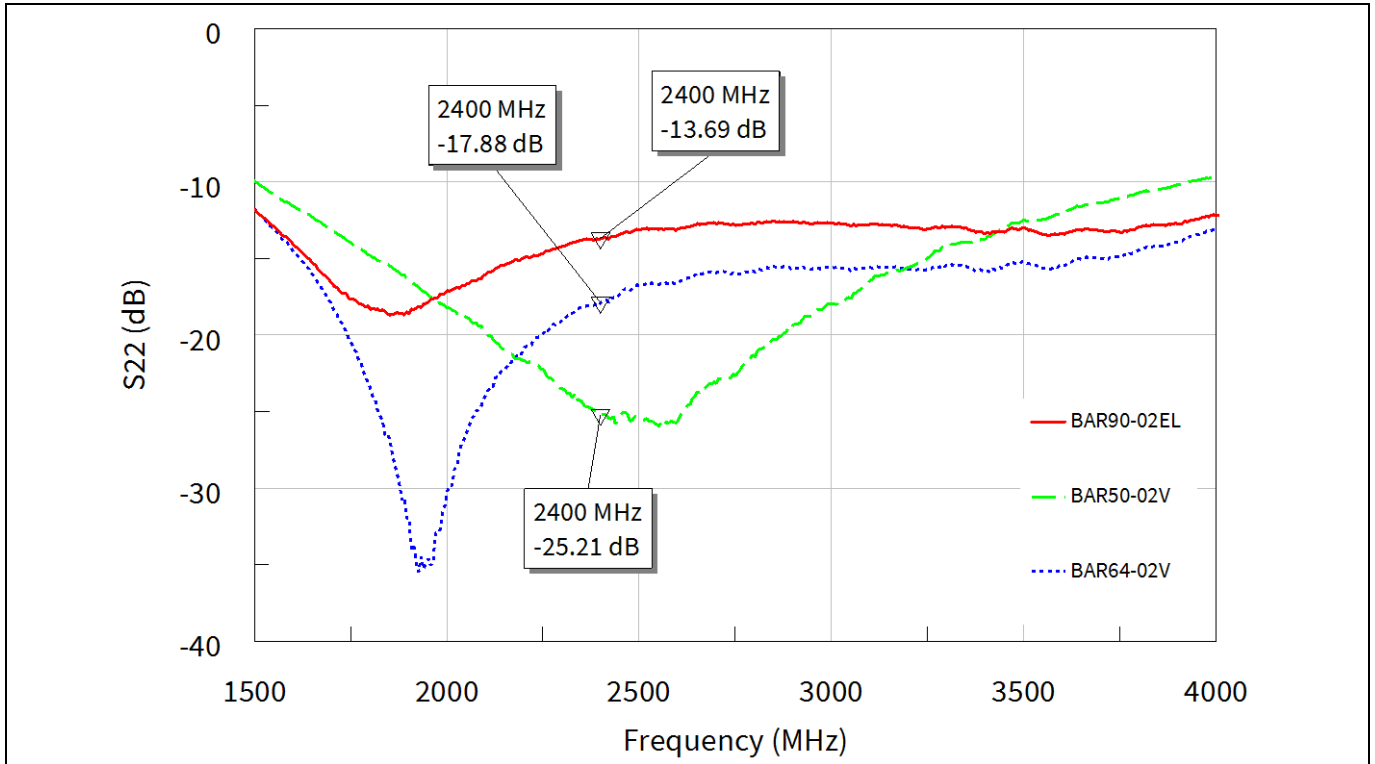

Figure 31 Output return loss of the SPDT series switch with [BAR50-02V](#), [BAR64-02V](#) and [BAR90-02EL](#) in ANT-Tx mode ($I_{bias1} = 10\text{ mA}$)

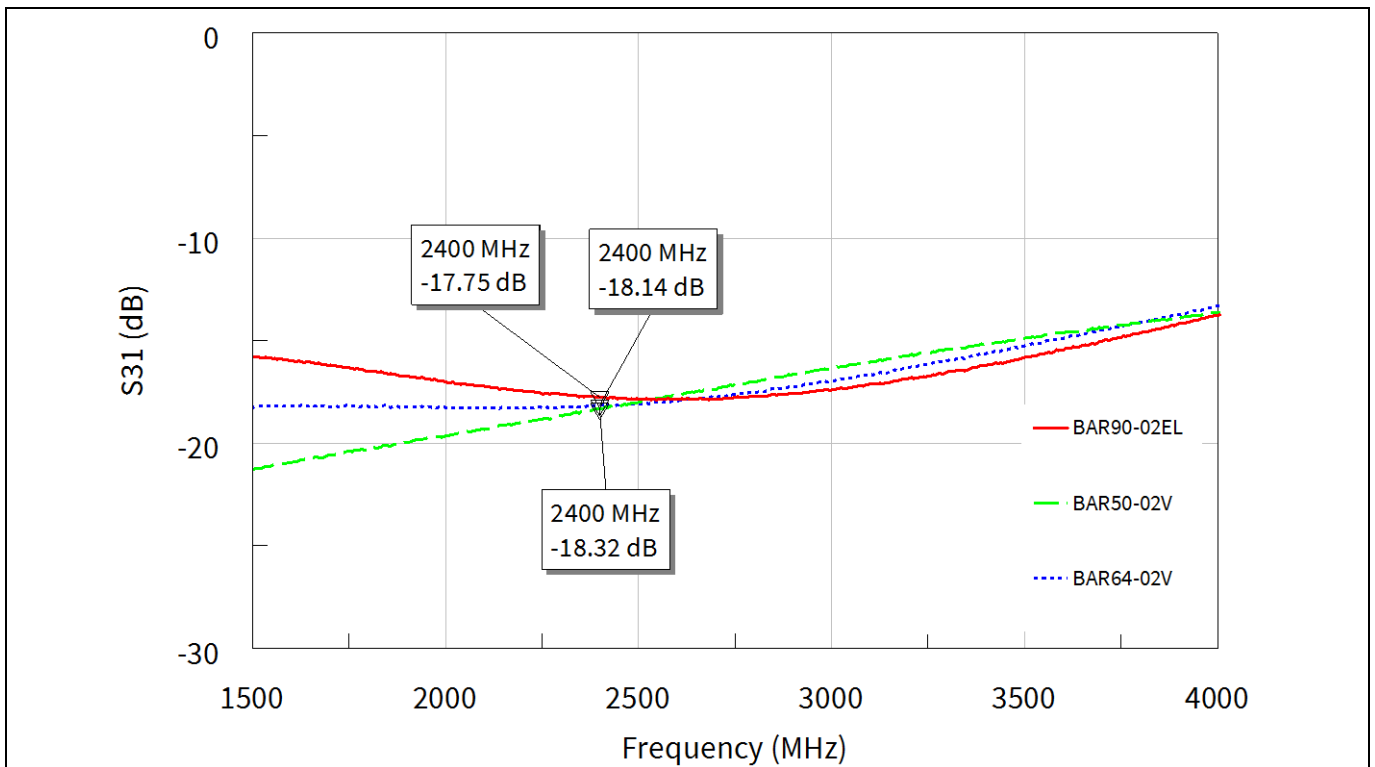

Figure 32 ANT-Rx isolation of the SPDT series switch with [BAR50-02V](#), [BAR64-02V](#) and [BAR90-02EL](#) in ANT-Tx mode ($I_{bias1} = 10\text{ mA}$)

PIN diode SPDT series switches

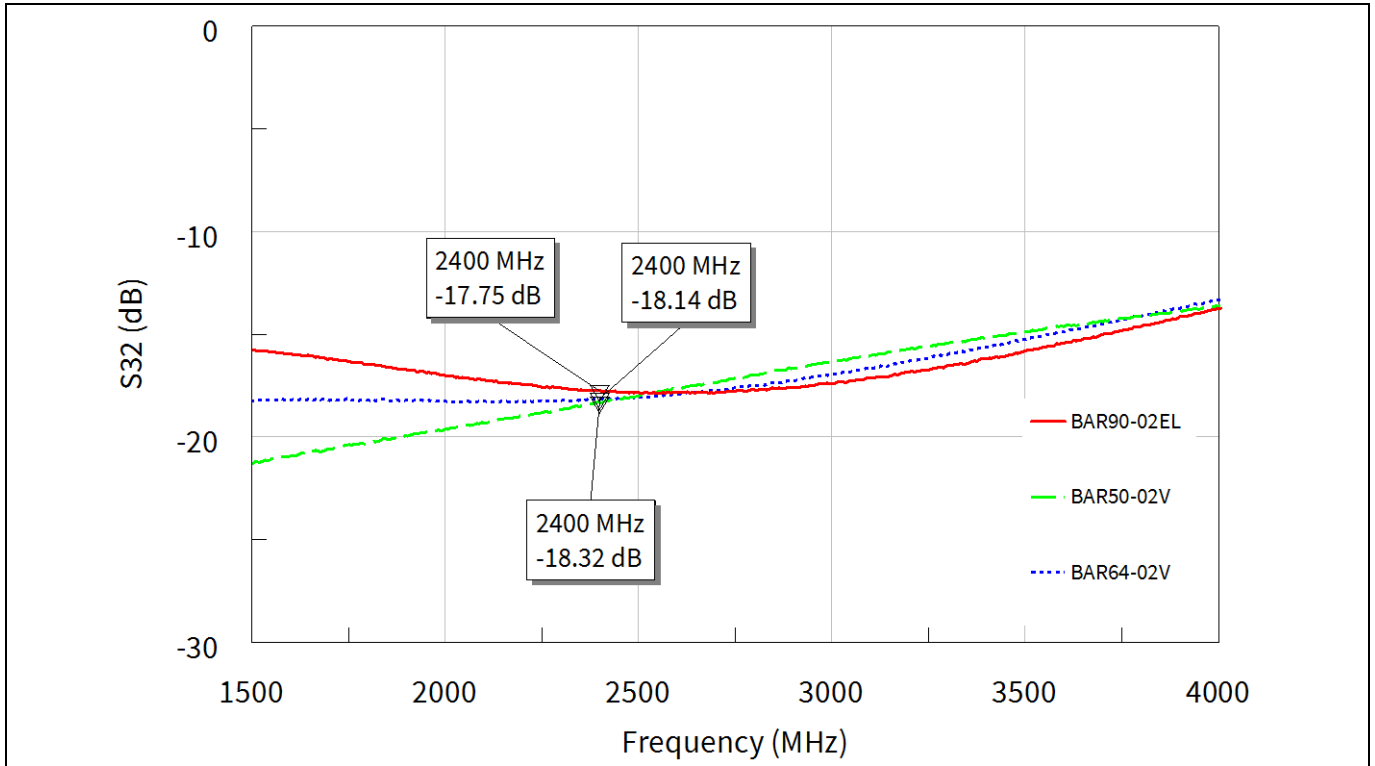

Figure 33 Tx-Rx isolation of the SPDT series switch with [BAR50-02V](#), [BAR64-02V](#) and [BAR90-02EL](#) in ANT-Tx mode ($I_{bias1} = 10\text{ mA}$)

4 PIN diode SPDT series and shunt switches

4.1 Sub-GHz range

4.1.1 Performance overview

The following tables show the SPDT series and shunt switch performance with PIN diode [BAR63-02L](#).

Table 12 Summary of measurement results of the SPDT series switch circuit for ANT-Tx mode

Parameter	Symbol	Value	Unit	Notes
Device		BAR63-02L		
Bias voltage	V_{bias1}	3.3	V	Mode: ANT-Tx ($V_{bias2} = 0$ V)
Bias current	I_{bias1}	9.8	mA	Mode: ANT-Tx ($I_{bias2} = 0$ A)
Frequency	f	300 to 1000	MHz	
Input return loss	RL_{in}	>14.8	dB	
Output return loss	RL_{out}	>15.5	dB	
Insertion loss	IL	0.48 ¹⁾ 0.28 ²⁾ 0.33 ³⁾	dB	SMA and PCB losses subtracted 1) Measured at 315 MHz (losses = 0.05 dB) 2) Measured at 434 MHz (losses = 0.06 dB) 3) Measured at 868 MHz (losses = 0.12 dB)
Isolation Tx-Rx	ISO_{Tx-Rx}	39.2 ⁴⁾ 38.8 ⁵⁾ 47.2 ⁶⁾	dB	4) Measured at 315 MHz 5) Measured at 434 MHz 6) Measured at 868 MHz
Isolation ANT-Rx	ISO_{ANT-Rx}	38.8 ⁴⁾ 38.5 ⁵⁾ 47.9 ⁶⁾	dB	
Input third order intercept point	IIP_3	>45	dBm	Measured at $P_{IN} = 5$ dBm
Third order intermodulation distortion	IMD3	>85	dBc	

PIN diode SPDT series and shunt switches

Table 13 Summary of measurement results of the SPDT series switch circuit for ANT-Rx mode

Parameter	Symbol	Value	Unit	Notes
Device		BAR63-02L		
Bias voltage	V_{bias2}	3.3	V	Mode: ANT-Rx ($V_{bias1} = 0$ V)
Bias current	I_{bias2}	9.8	mA	Mode: ANT-Rx ($I_{bias1} = 0$ A)
Frequency	f	300 to 1000	MHz	
Input return loss	RL_{in}	>14.7	dB	
Output return loss	RL_{out}	>14.5	dB	
Insertion loss	IL	0.49 ¹⁾ 0.28 ²⁾ 0.34 ³⁾	dB	SMA and PCB losses subtracted 1) Measured at 315 MHz (losses = 0.05 dB) 2) Measured at 434 MHz (losses = 0.06 dB) 3) Measured at 868 MHz (losses = 0.12 dB)
Isolation Tx-Rx	ISO_{Tx-Rx}	38.7 ⁴⁾ 38.6 ⁵⁾ 46.5 ⁶⁾	dB	4) Measured at 315 MHz 5) Measured at 434 MHz 6) Measured at 868 MHz
Isolation ANT-Tx	ISO_{ANT-Tx}	38.7 ⁴⁾ 38.4 ⁵⁾ 46.8 ⁶⁾	dB	
Input third order intercept point	IIP_3	>45	dBm	Measured at $P_{IN} = 5$ dBm
Third order intermodulation distortion	IMD3	>85	dBc	

4.1.2 Schematic

The following figure shows the schematic of the SPDT series and shunt switch. In the schematic, each branch of the switch contains one series and one shunt-connected PIN diode. The resistors R2 and R3 are used to set the bias current for series-connected diodes in the branch one and the branch two of the switch respectively, while the resistors R1 and R4 are used to set the bias current for shunt-connected diodes in each branch. The inductors L2 and L5 provide the DC return path for the bias current of the series-connected diodes. The capacitors C3, C5, C6 and C9 serve as the RF bypass. The capacitors C4 and C7 provide the DC block and the matching at the common input port. The matching network at output port one is formed by the capacitors C1 and C2 and the inductor L2, and the matching network at output two is formed by the capacitors C8 and C10 and the inductor L5.

PIN diode SPDT series and shunt switches

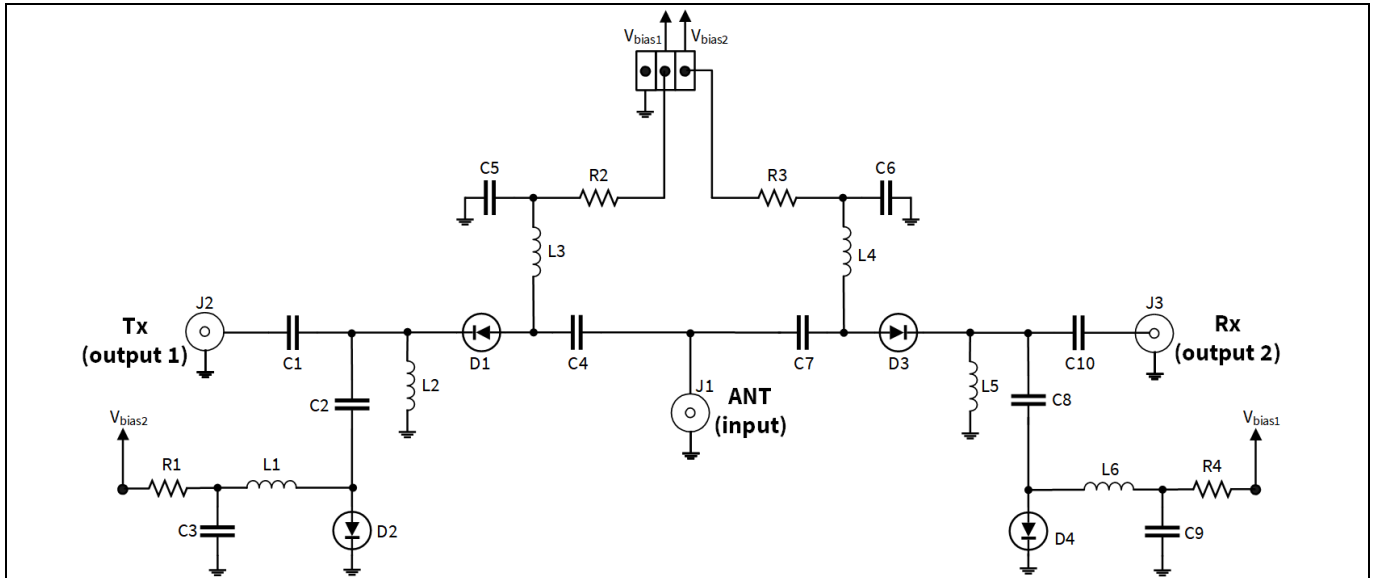

Figure 34 The SPDT series and shunt switch schematic

4.1.3 BOM

Table 14 BOM of the SPDT series and shunt switch circuit with [BAR63-02L](#)

Symbol	Value	Unit	Size	Manufacturer	Comment
D1–D4	BAR63-02L	–	TSLP-2	Infineon	PIN diode
C1	39	pF	0402	Various	DC block and Tx matching
C2	15	pF	0402	Various	DC block and Tx matching
C3	220	nF	0402	Various	RF bypass
C4	39	pF	0402	Various	DC block and input matching
C5	220	nF	0402	Various	RF bypass
C6	220	nF	0402	Various	RF bypass
C7	39	pF	0402	Various	DC block and input matching
C8	15	pF	0402	Various	DC block and Rx matching
C9	220	nF	0402	Various	RF bypass
C10	39	pF	0402	Various	DC block and Rx matching
L1	68	nH	0402	Murata LQW	RF choke
L2	150	nH	0402	Murata LQG	DC return, Tx branch
L3	150	nH	0402	Murata LQG	RF choke

PIN diode SPDT series and shunt switches

Symbol	Value	Unit	Size	Manufacturer	Comment
L4	150	nH	0402	Murata LQG	RF choke
L5	150	nH	0402	Murata LQG	DC return, Rx branch
L6	68	nH	0402	Murata LQW	RF choke
R1	470	Ω	0402	Various	DC bias
R2	510	Ω	0402	Various	DC bias
R3	510	Ω	0402	Various	DC bias
R4	470	Ω	0402	Various	DC bias

4.1.4 Evaluation board and layout information

The evaluation board information for the SPDT series and shunt switch circuit with [BAR63-02L](#):

- PCB material: FR4
- PCB marking: M180629 RF Diode 4

Images of the evaluation board and the PCB stack information are shown in the following figures.

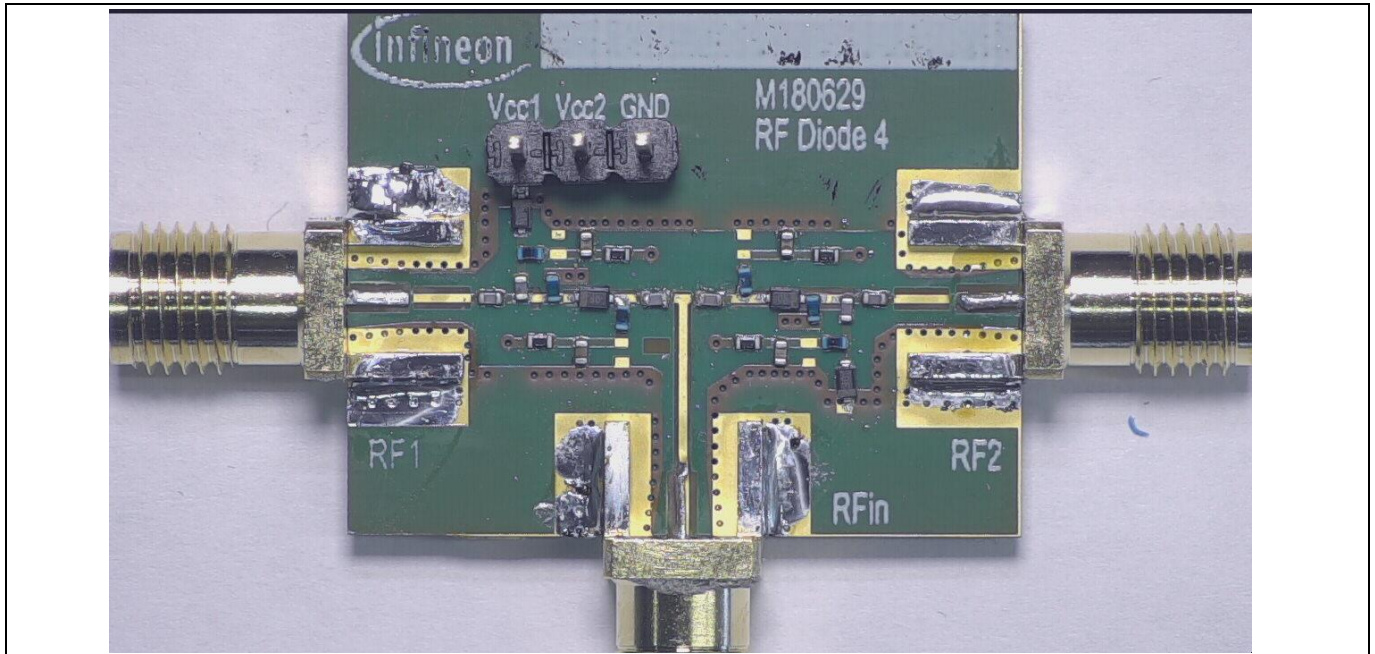

Figure 35 Photo of the evaluation board for PIN diode SPDT series and shunt switch with [BAR63-02L](#)

PIN diode SPDT series and shunt switches

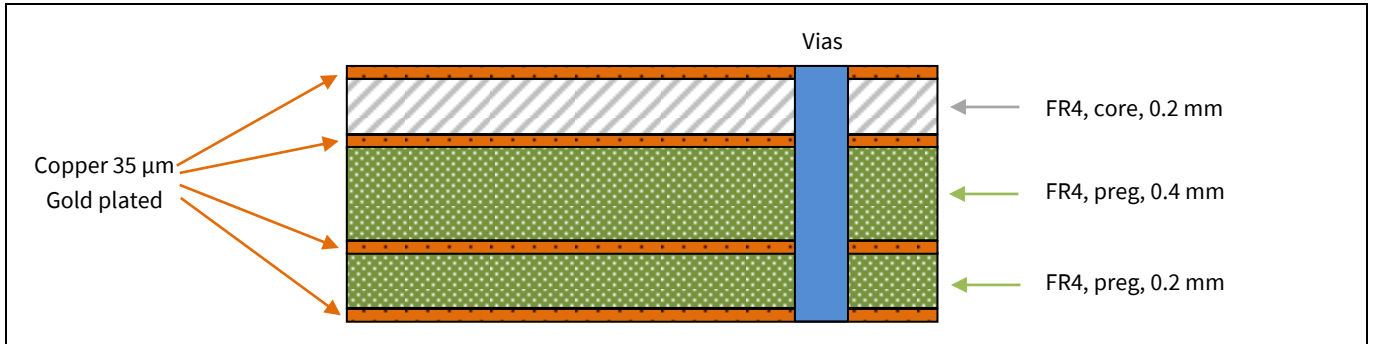

Figure 36 PCB stack information of the evaluation board for PIN diode SPDT switch

4.1.5 Measurement graphs

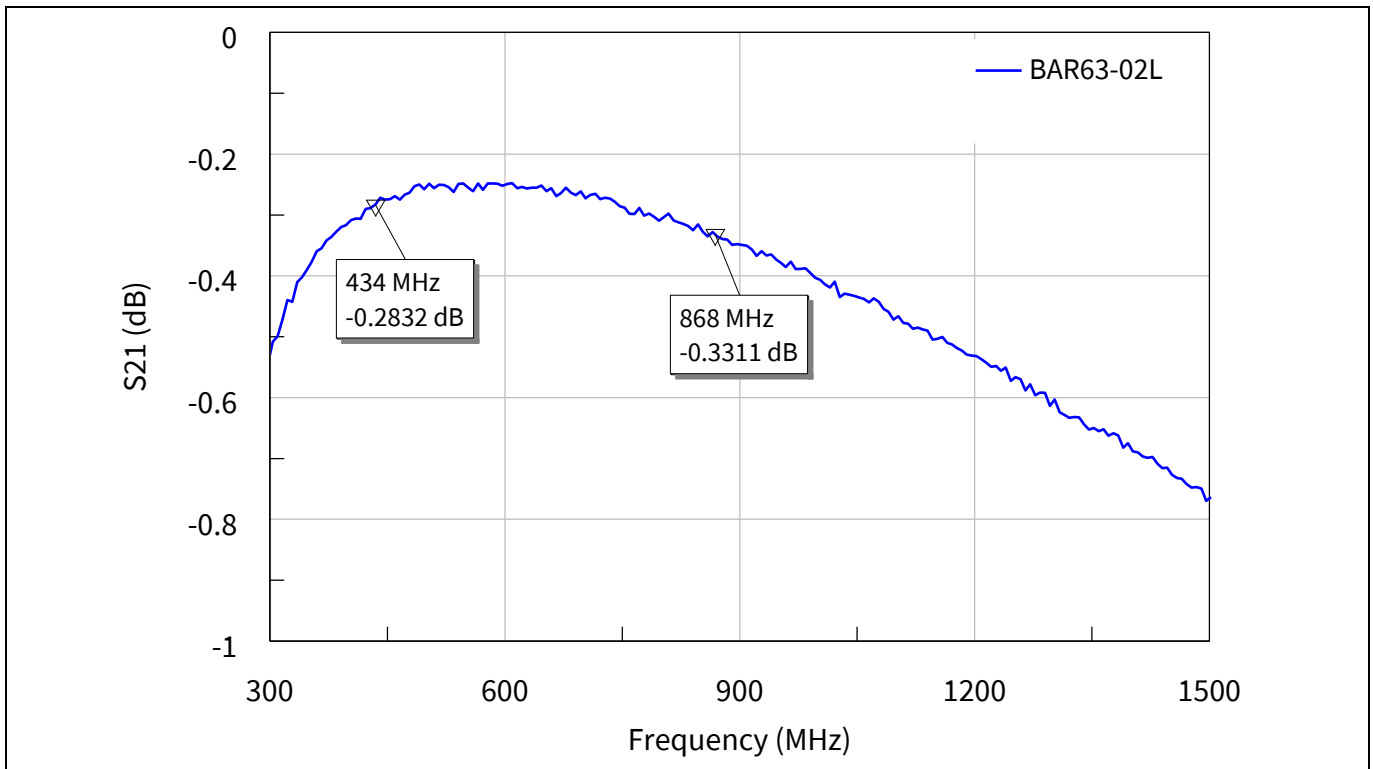

Figure 37 Insertion loss of the SPDT series and shunt switch with [BAR63-02L](#) in ANT-Tx mode ($I_{bias1} = 9.8 \text{ mA}$)

PIN diode SPDT series and shunt switches

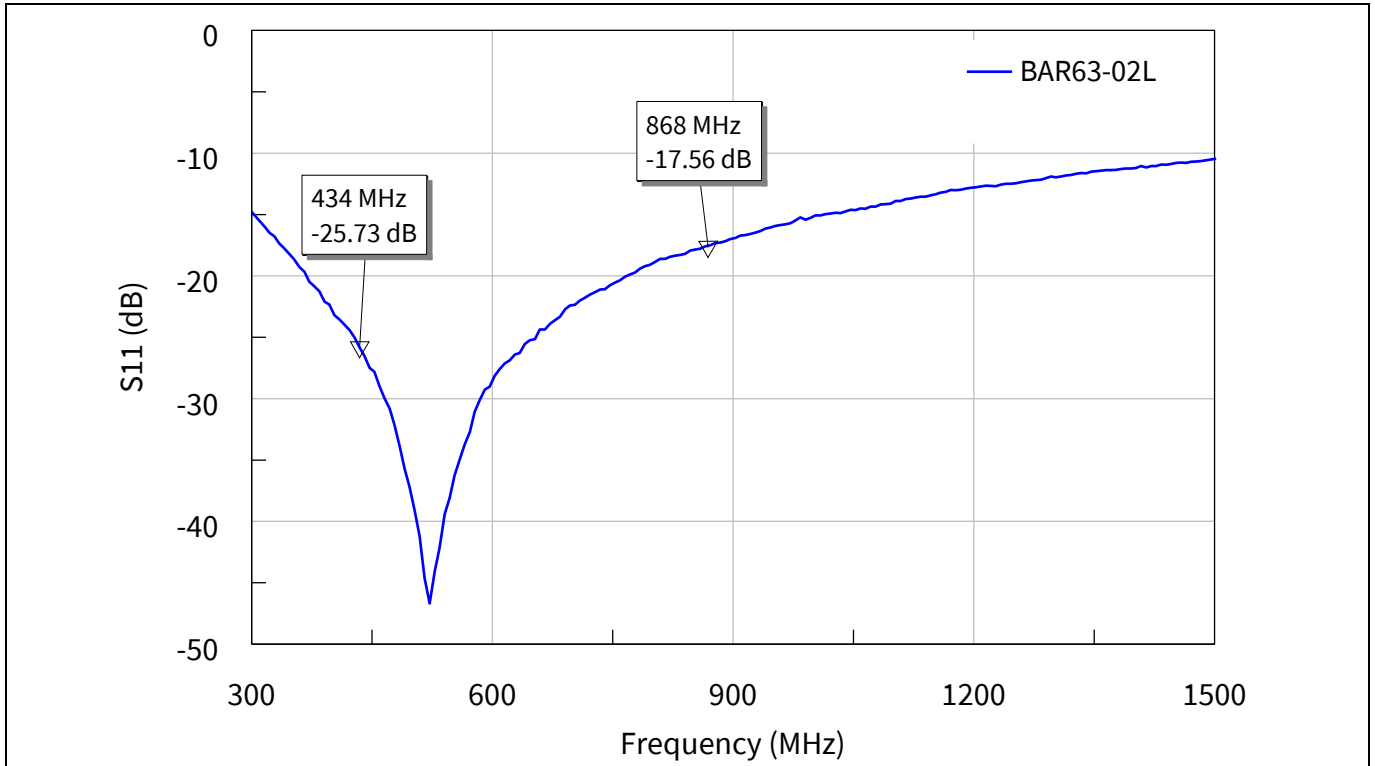

Figure 38 Input return loss of the SPDT series and shunt switch with [BAR63-02L](#) in ANT-Tx mode ($I_{bias1} = 9.8 \text{ mA}$)

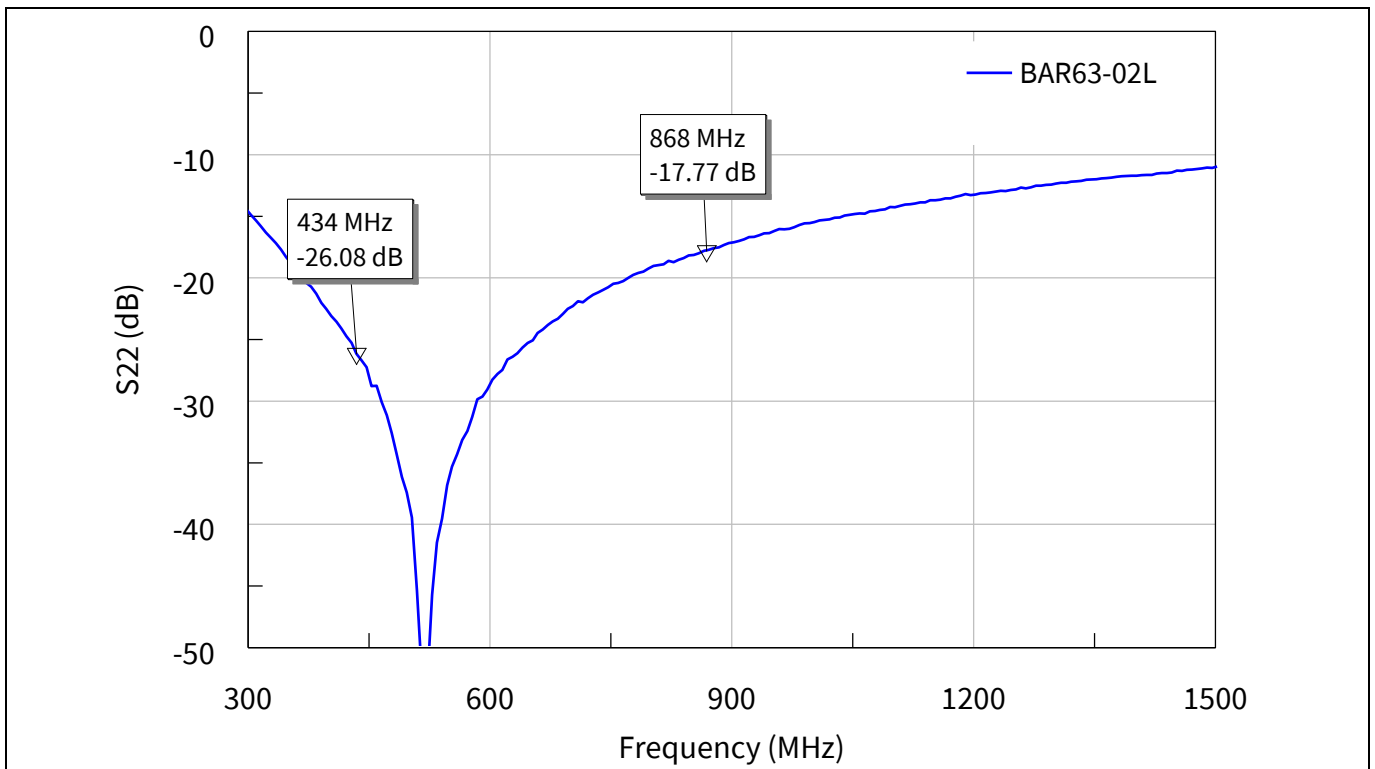

Figure 39 Output return loss of the SPDT series and shunt switch with [BAR63-02L](#) in ANT-Tx mode ($I_{bias1} = 9.8 \text{ mA}$)

PIN diode SPDT series and shunt switches

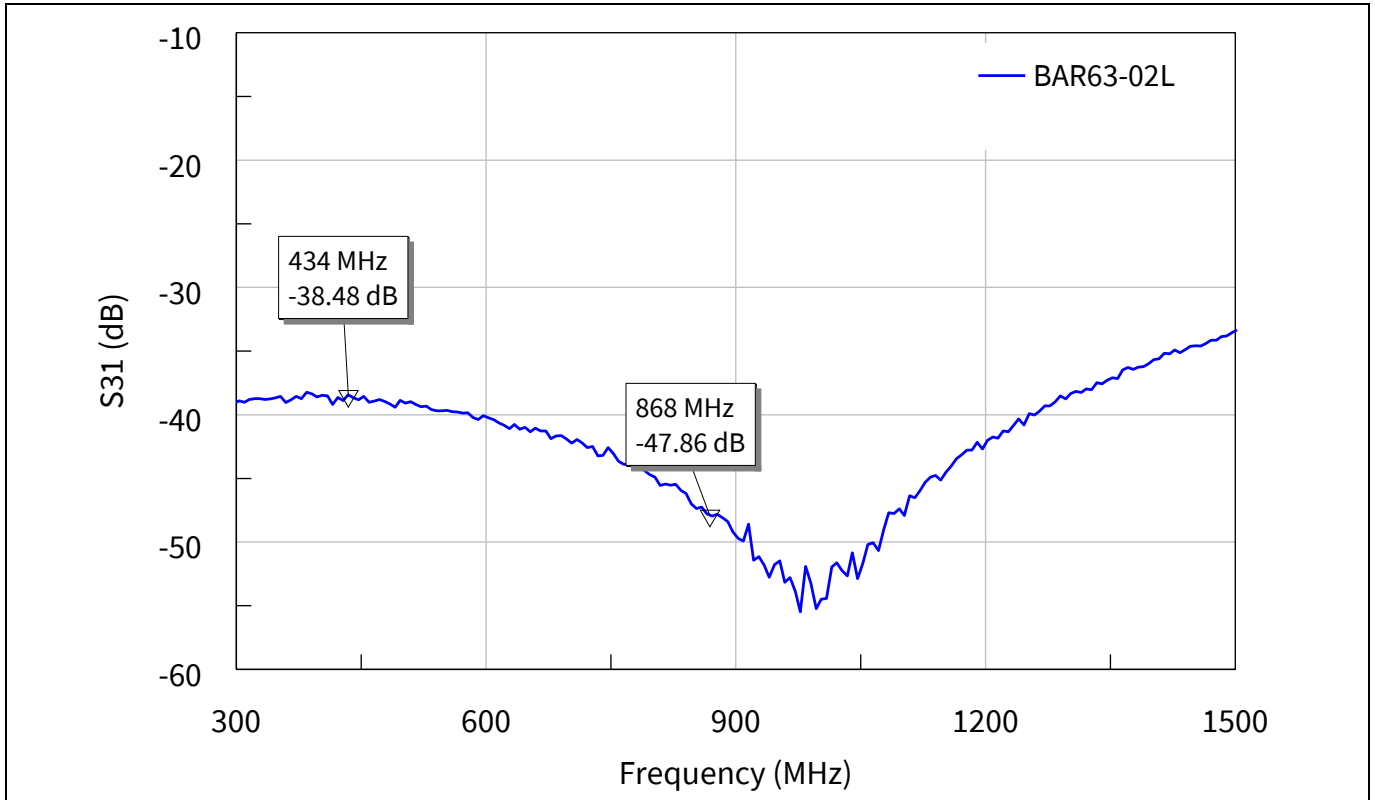

Figure 40 ANT-Rx isolation of the SPDT series and shunt switch with [BAR63-02L](#) in ANT-Tx mode ($I_{bias1} = 9.8 \text{ mA}$)

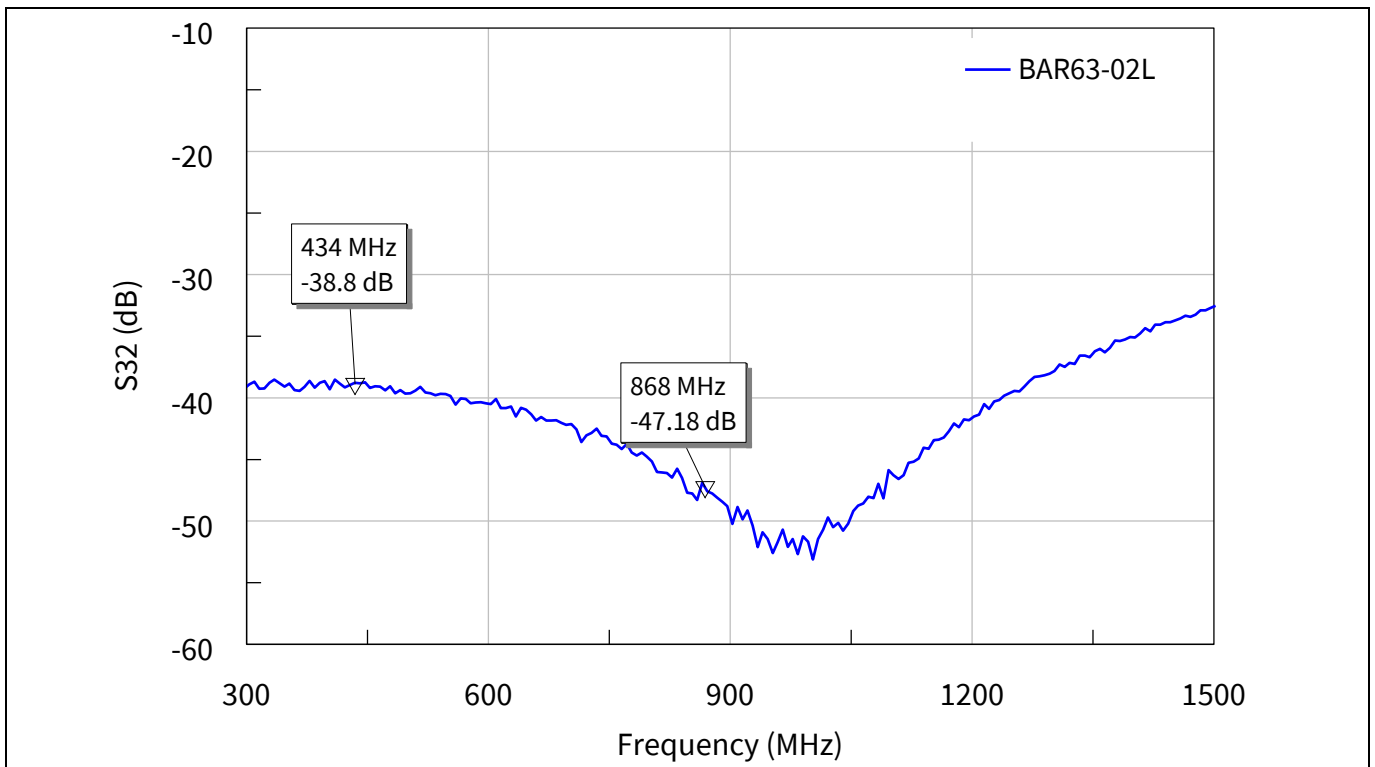

Figure 41 Tx-Rx isolation of the SPDT series and shunt switch with [BAR63-02L](#) in ANT-Tx mode ($I_{bias1} = 9.8 \text{ mA}$)

PIN diode SPDT series and shunt switches

4.2 S-band range

4.2.1 Performance overview

The following tables show the SPDT series and shunt switch performance with PIN diodes [BAR50-02V](#), [BAR64-02V](#) and [BAR90-02EL](#).

Table 15 Summary of measurement results of the SPDT series and shunt switch circuits for ANT-Tx mode

Parameter	Symbol	Value			Unit	Notes
Device		BAR50-02V	BAR64-02V	BAR90-02EL		
Bias voltage	V_{bias1}	3.3	3.3	3.3	V	Mode: ANT-Tx ($V_{bias2} = 0\text{ V}$)
Bias current	I_{bias1}	10	10	10	mA	Mode: ANT-Tx ($I_{bias2} = 0\text{ A}$)
Frequency	f	1.5 to 3.7	1.5 to 3.7	1.5 to 3.7	GHz	
Input return loss	RL_{in}	>9.7	>9.5	>10.4	dB	
Output return loss	RL_{out}	>11.1	>11.2	>11.7	dB	
Insertion loss	IL	1.04 ¹⁾ 1.15 ²⁾ 1.47 ³⁾	0.79 ¹⁾ 0.79 ²⁾ 1.22 ³⁾	0.66 ¹⁾ 0.77 ²⁾ 1.10 ³⁾	dB	SMA and PCB losses subtracted 1) Measured at 1.9 GHz (losses = 0.27 dB) 2) Measured at 2.4 GHz (losses = 0.36 dB) 3) Measured at 3.5 GHz (losses = 0.50 dB)
Isolation Tx-Rx	ISO_{Tx-Rx}	33.9 ⁴⁾ 39.4 ⁵⁾ 22.7 ⁶⁾	32.3 ⁴⁾ 40.1 ⁵⁾ 21.5 ⁶⁾	29.3 ⁴⁾ 38.1 ⁵⁾ 19.2 ⁶⁾	dB	4) Measured at 1.9 GHz 5) Measured at 2.4 GHz 6) Measured at 3.5 GHz
Isolation ANT-Rx	ISO_{ANT-Rx}	34.2 ⁴⁾ 40.3 ⁵⁾ 23.5 ⁶⁾	32.4 ⁴⁾ 40.4 ⁵⁾ 22.4 ⁶⁾	29.7 ⁴⁾ 39.2 ⁵⁾ 20.5 ⁶⁾	dB	
Input third order intercept point	IIP_3	>45	>45	>45	dBm	
Third order intermodulation distortion	IMD3	>85	>85	>85	dBc	Measured at $P_{IN} = 5\text{ dBm}$

PIN diode SPDT series and shunt switches

Table 16 Summary of measurement results of the SPDT series and shunt switch circuits for ANT-Rx mode

Parameter	Symbol	Value			Unit	Notes
Device		BAR50-02V	BAR64-02V	BAR90-02EL		
Bias voltage	V_{bias2}	3.3	3.3	3.3	V	Mode: ANT-Rx ($V_{bias1} = 0$ V)
Bias current	I_{bias2}	10.1	10	10	mA	Mode: ANT-Rx ($I_{bias1} = 0$ A)
Frequency	f	1.5 to 3.7	1.5 to 3.7	1.5 to 3.7	GHz	
Input return loss	RL_{in}	>9.8	>10.1	>10.5	dB	
Output return loss	RL_{out}	>11.4	>12	>11.6	dB	
Insertion loss	IL	1.02 ¹⁾ 1.08 ²⁾ 1.47 ³⁾	0.78 ¹⁾ 0.81 ²⁾ 1.27 ³⁾	0.73 ¹⁾ 0.79 ²⁾ 1.14 ³⁾	dB	SMA and PCB losses subtracted 1) Measured at 1.9 GHz (losses = 0.27 dB) 2) Measured at 2.4 GHz (losses = 0.36 dB) 3) Measured at 3.5 GHz (losses = 0.50 dB)
Isolation Tx-Rx	ISO_{Tx-Rx}	34.2 ⁴⁾ 39.7 ⁵⁾ 22.7 ⁶⁾	30.3 ⁴⁾ 39.2 ⁵⁾ 19.6 ⁶⁾	30.2 ⁴⁾ 39.9 ⁵⁾ 20.8 ⁶⁾	dB	4) Measured at 1.9 GHz 5) Measured at 2.4 GHz 6) Measured at 3.5 GHz
Isolation ANT-Tx	ISO_{ANT-Tx}	34.1 ⁴⁾ 40.2 ⁵⁾ 22.1 ⁶⁾	30.3 ⁴⁾ 39.8 ⁵⁾ 18.8 ⁶⁾	29.7 ⁴⁾ 39.3 ⁵⁾ 19.6 ⁶⁾	dB	
Input third order intercept point	IIP_3	>45	>45	>45	dBm	
Third order intermodulation distortion	IMD3	>85	>85	>85	dBc	Measured at $P_{IN} = 5$ dBm

4.2.2 Schematic

The following figure shows the schematic of the SPDT series and shunt switch. In the schematic, each branch of the switch contains one series- and one shunt-connected PIN diode. The resistors R2 and R3 are used to set the bias current for series-connected diodes in branches one and two of the switch respectively, while the resistors R1 and R4 are used to set the bias current for shunt-connected diodes in each branch. The inductors L2 and L5 provide the DC return path for the bias current of the series-connected diodes. The capacitors C3, C5, C6 and C9 serve as the RF bypass. The capacitors C4 and C7 provide the DC block and the matching at the common input port. The matching network at output port one is formed by the capacitors C1 and C2 and the inductor L2. The matching network at output two is formed by the capacitors C8 and C10 and the inductor L5.

PIN diode SPDT series and shunt switches

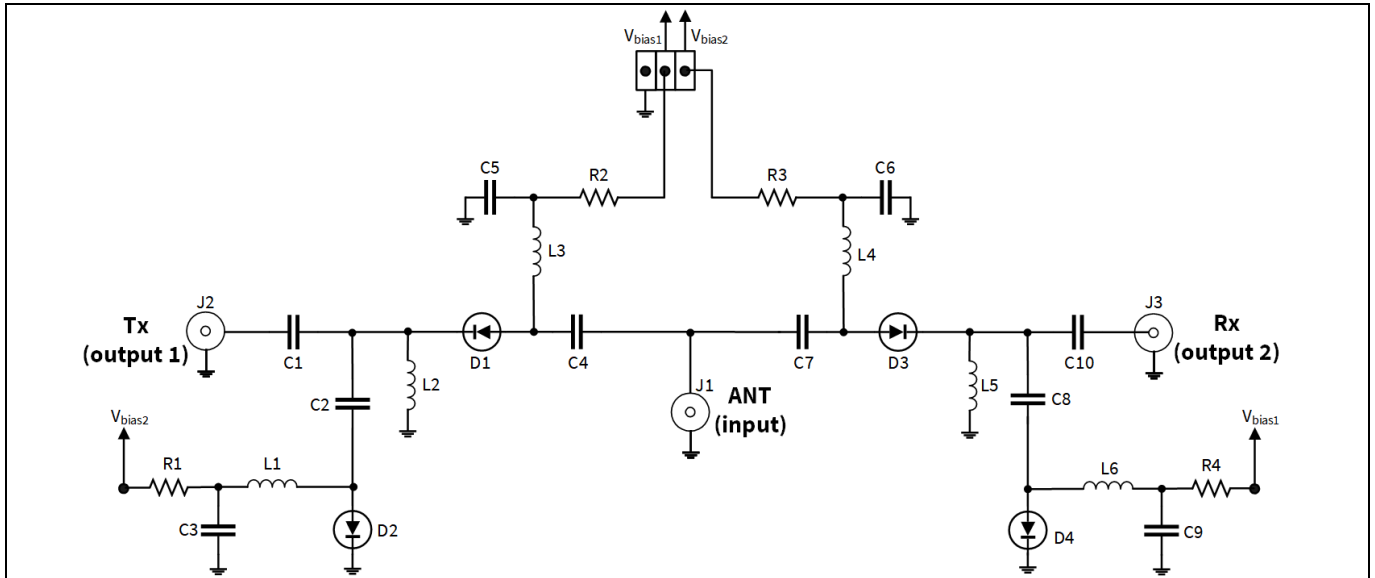

Figure 42 The SPDT series and shunt switch schematic

4.2.3 BOM

Table 17 BOM of the SPDT series and shunt switch circuits with [BAR50-02V](#), [BAR64-02V](#) and [BAR90-02EL](#)

Symbol	Value			Unit	Size	Manufacturer	Comment
D1 – D4	BAR50-02V (SC79)	BAR64-02V (SC79)	BAR90-02EL (TSLP-2)	-	-	Infineon	PIN diode
C1	6.8	3.3	2.7	pF	0402	Various	DC block and Tx matching
C2	2.2	2.2	2.2	pF	0402	Various	DC block and Tx matching
C3	220	220	220	nF	0402	Various	RF bypass
C4	6.8	3.3	2.7	pF	0402	Various	DC block and input matching
C5	220	220	220	nF	0402	Various	RF bypass
C6	220	220	220	nF	0402	Various	RF bypass
C7	6.8	3.3	2.7	pF	0402	Various	DC block and input matching
C8	2.2	2.2	2.2	pF	0402	Various	DC block and Rx matching
C9	220	220	220	nF	0402	Various	RF bypass
C10	6.8	3.3	2.7	pF	0402	Various	DC block and Rx matching
L1	68	68	68	nH	0402	Murata LQW	RF choke
L2	68	6.8	6.8	nH	0402	Various	DC return, Tx branch

PIN diode SPDT series and shunt switches

Symbol	Value			Unit	Size	Manufacturer	Comment
L3	68	6.8	6.8	nH	0402	Various	RF choke
L4	68	6.8	6.8	nH	0402	Various	RF choke
L5	68	6.8	6.8	nH	0402	Various	DC return, Rx branch
L6	68	68	68	nH	0402	Murata LQW	RF choke
R1	560	560	560	Ω	0402	Various	DC bias
R2	560	560	560	Ω	0402	Various	DC bias
R3	560	560	560	Ω	0402	Various	DC bias
R4	560	560	560	Ω	0402	Various	DC bias

4.2.4 Evaluation board and layout information

The evaluation board information for the SPDT series and shunt switch circuit with [BAR50-02V](#), [BAR64-02V](#) and [BAR90-02EL](#):

- PCB material: FR4
- PCB marking: M180629 RF Diode 4

Images of the evaluation board and the PCB stack information are shown in the following figures.

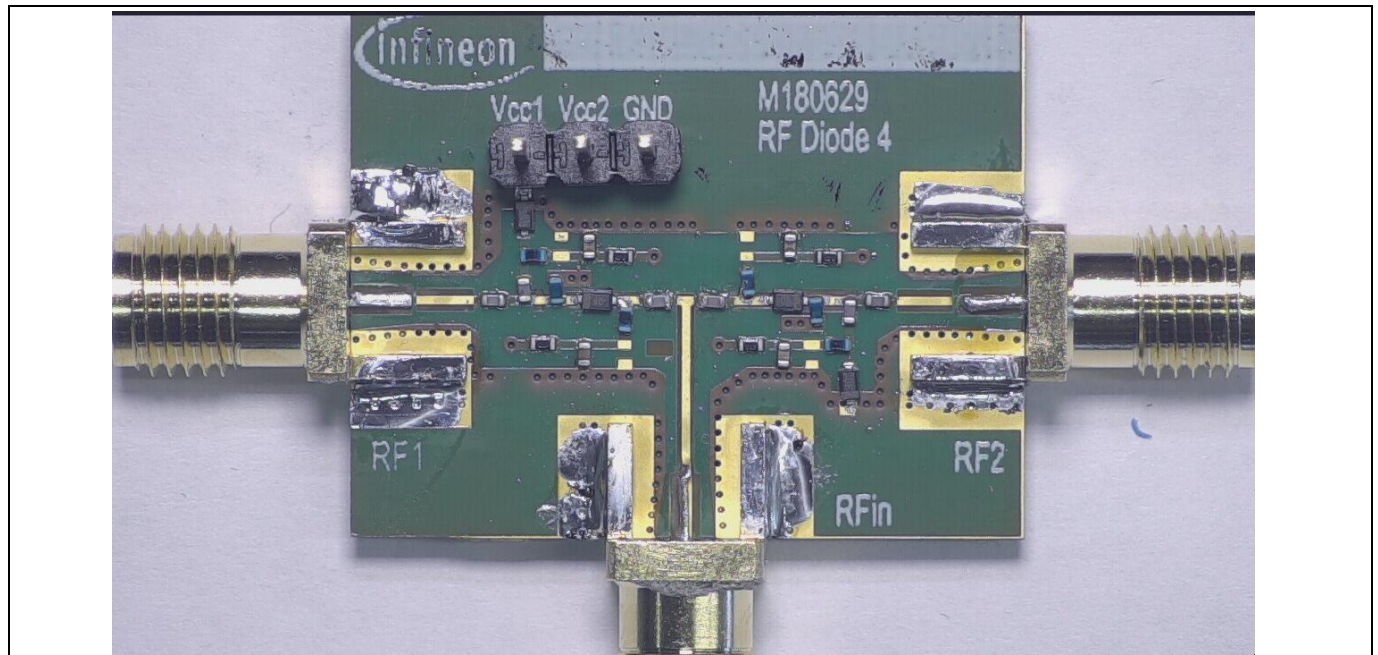

Figure 43 Photo of the evaluation board for the PIN diode SPDT series and shunt switch with [BAR50-02V](#), [BAR64-02V](#) and [BAR90-02EL](#)

PIN diode SPDT series and shunt switches

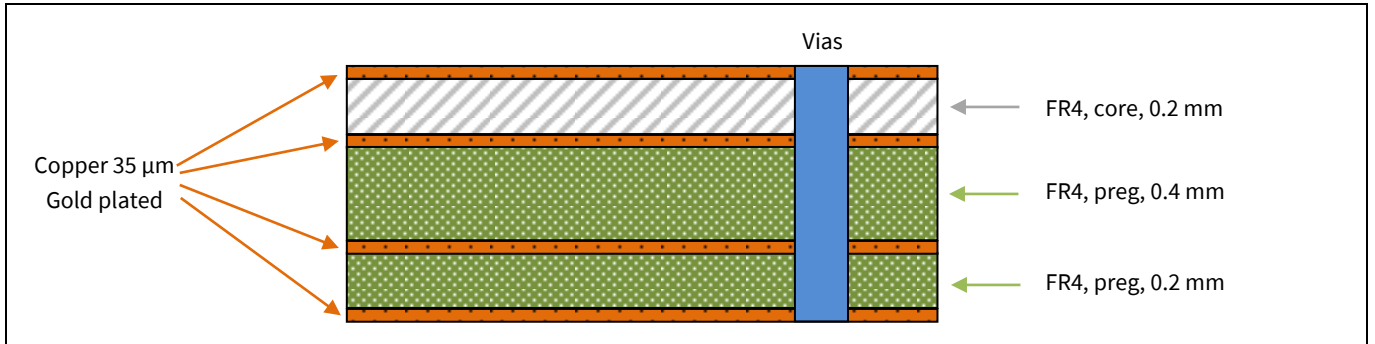

Figure 44 PCB stack information of the evaluation board for the PIN diode SPDT switch

4.2.5 Measurement graphs

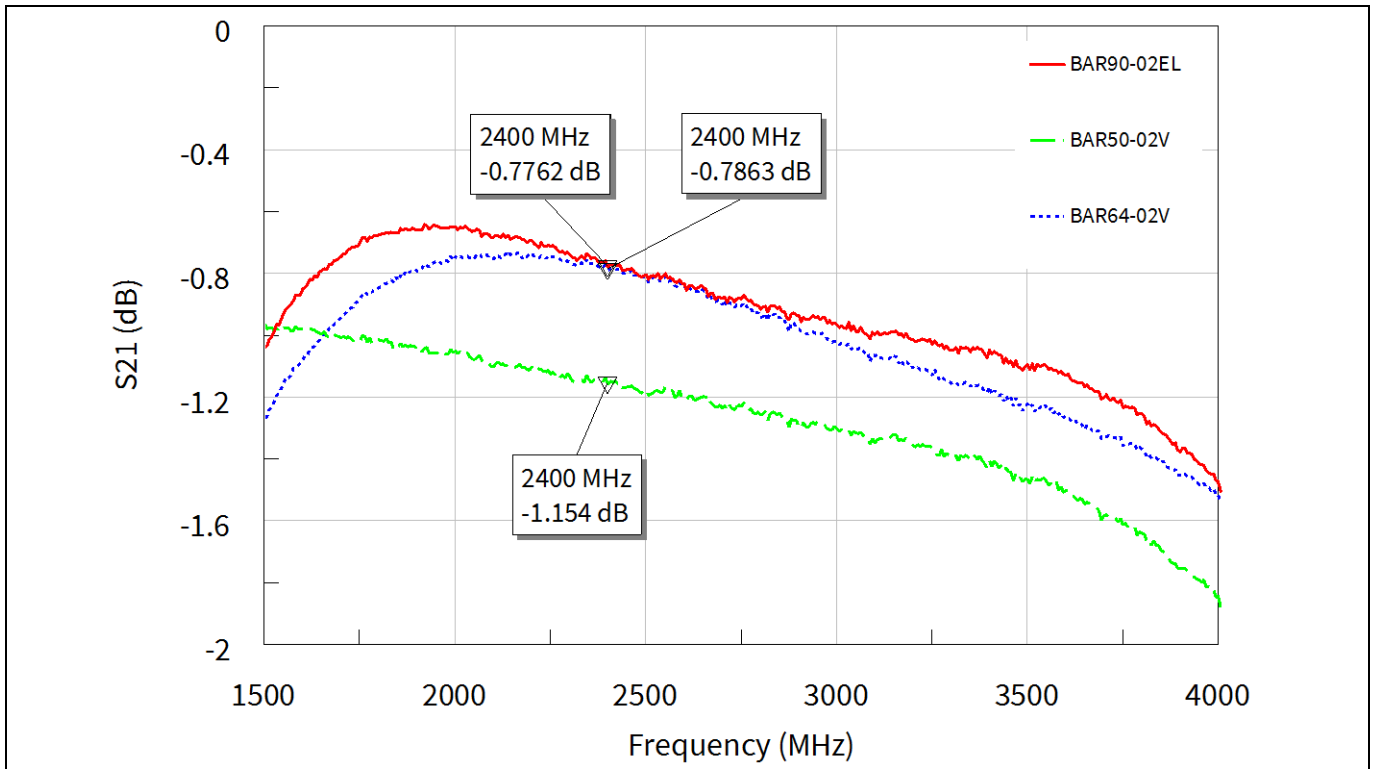

Figure 45 Insertion loss of the SPDT series and shunt switch with [BAR50-02V](#), [BAR64-02V](#) and [BAR90-02EL](#) in ANT-Tx mode ($I_{bias1} = 10 \text{ mA}$)

PIN diode SPDT series and shunt switches

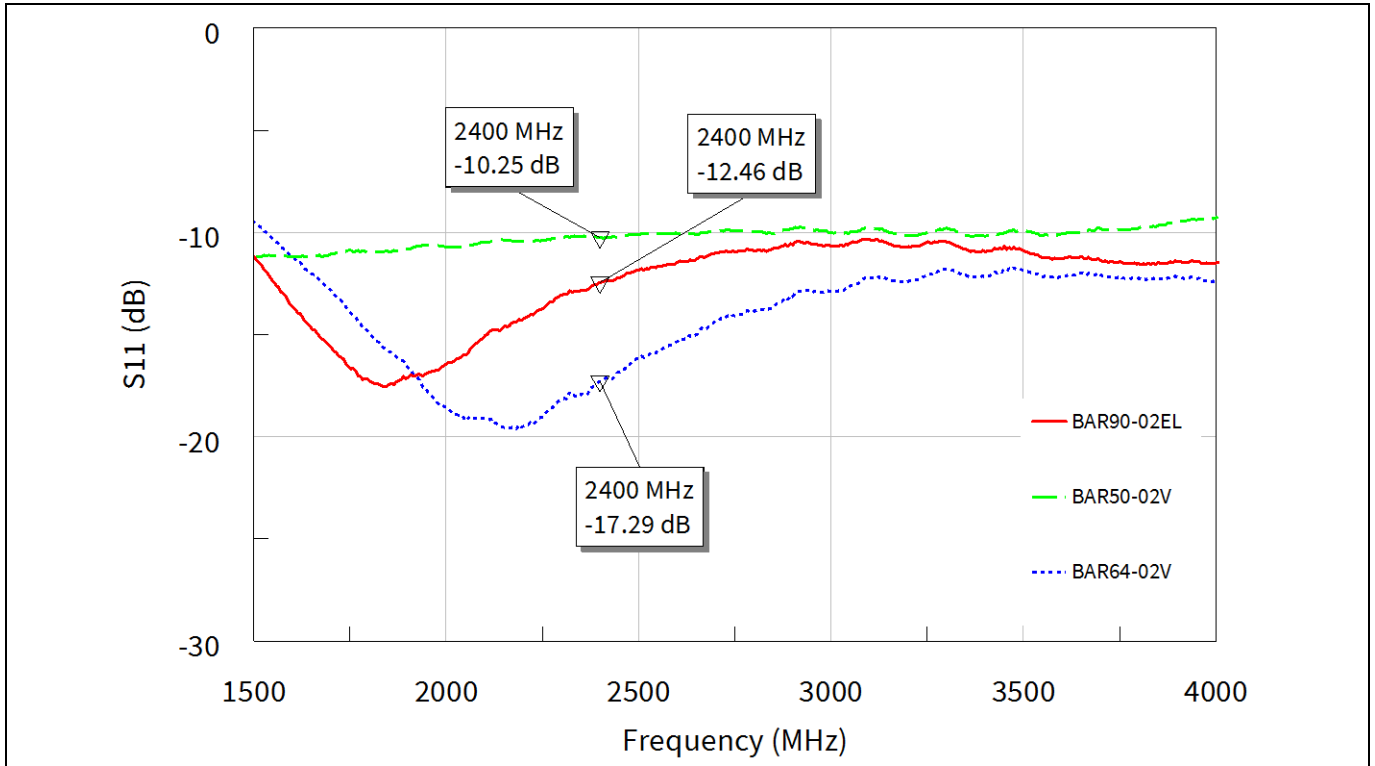

Figure 46 Input return loss of the SPDT series and shunt switch with [BAR50-02V](#), [BAR64-02V](#) and [BAR90-02EL](#) in ANT-Tx mode ($I_{bias1} = 10 \text{ mA}$)

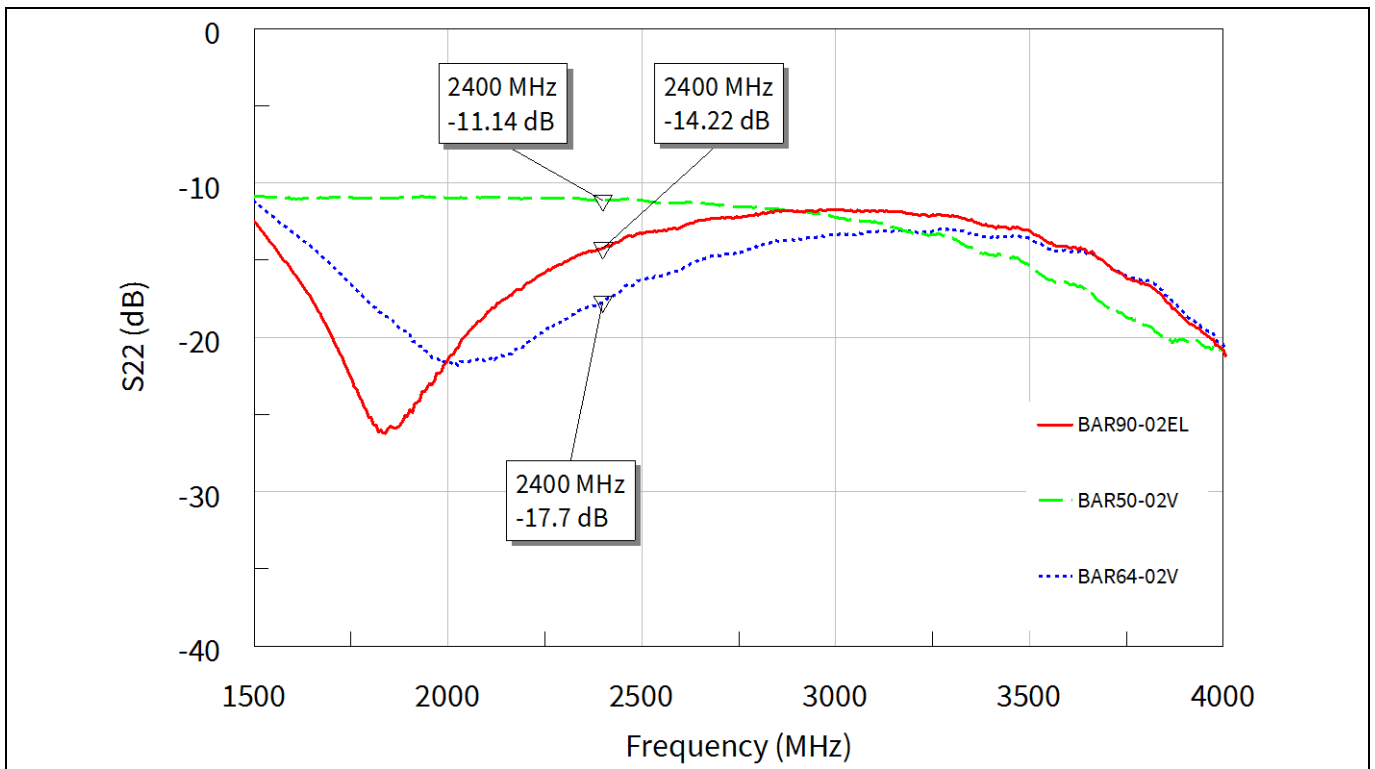

Figure 47 Output return loss of the SPDT series and shunt switch with [BAR50-02V](#), [BAR64-02V](#) and [BAR90-02EL](#) in ANT-Tx mode ($I_{bias1} = 10 \text{ mA}$)

PIN diode SPDT series and shunt switches

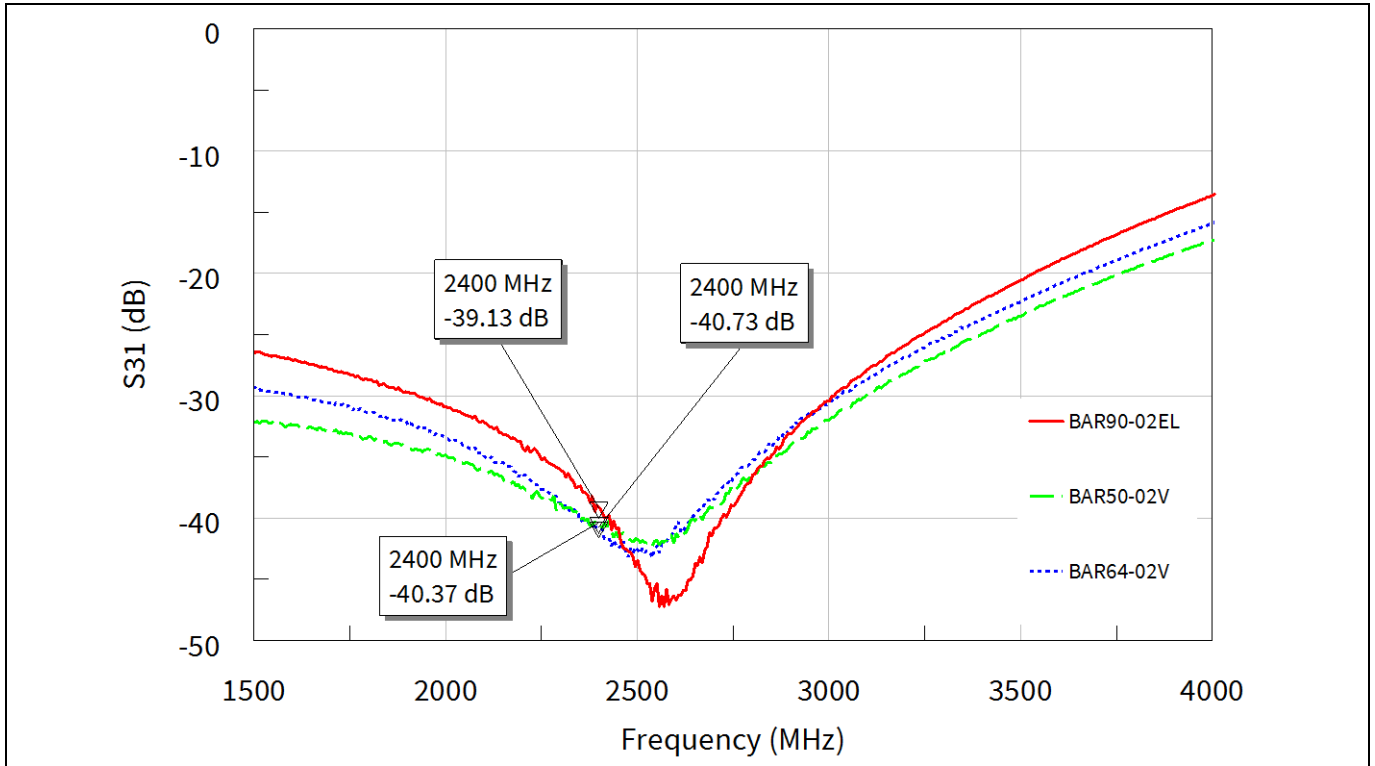

Figure 48 ANT-R_x isolation of the SPDT series and shunt switch with [BAR50-02V](#), [BAR64-02V](#) and [BAR90-02EL](#) in ANT-Tx mode ($I_{bias1} = 10\text{ mA}$)

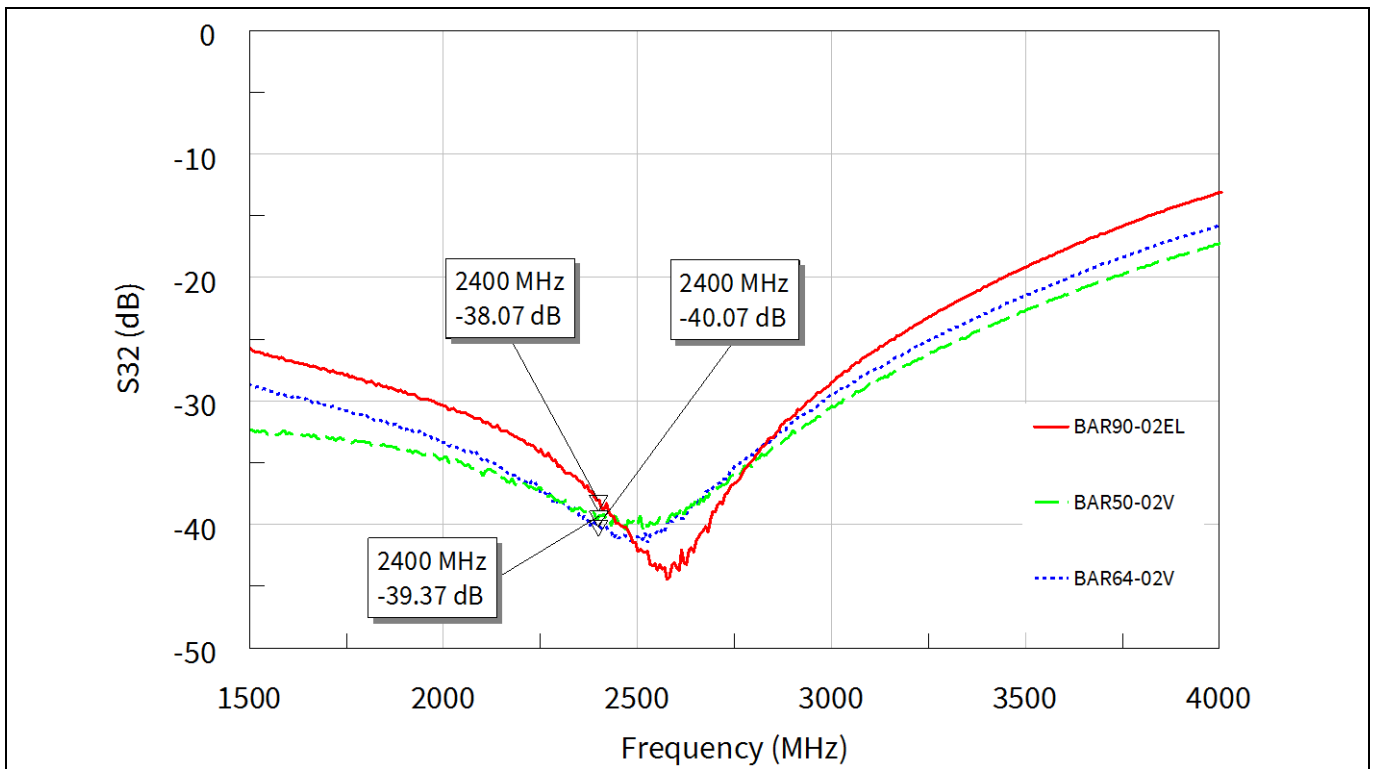

Figure 49 Tx-Rx isolation of the SPDT series and shunt switch with [BAR50-02V](#), [BAR64-02V](#) and [BAR90-02EL](#) in ANT-Tx mode ($I_{bias1} = 10\text{ mA}$)

Author

5 Author

Atif Mehmood, application engineer of business unit RF and sensors.



Revision history

Revision history

Document version	Date of release	Description of changes

Trademarks

All referenced product or service names and trademarks are the property of their respective owners.

Edition 2018-08-30

Published by

Infineon Technologies AG

81726 Munich, Germany

© 2018 Infineon Technologies AG.

All Rights Reserved.

Do you have a question about this document?

Email: erratum@infineon.com

Document reference

AN_1809_PL32_1810_172154

IMPORTANT NOTICE

The information contained in this application note is given as a hint for the implementation of the product only and shall in no event be regarded as a description or warranty of a certain functionality, condition or quality of the product. Before implementation of the product, the recipient of this application note must verify any function and other technical information given herein in the real application. Infineon Technologies hereby disclaims any and all warranties and liabilities of any kind (including without limitation warranties of non-infringement of intellectual property rights of any third party) with respect to any and all information given in this application note.

The data contained in this document is exclusively intended for technically trained staff. It is the responsibility of customer's technical departments to evaluate the suitability of the product for the intended application and the completeness of the product information given in this document with respect to such application.

For further information on the product, technology, delivery terms and conditions and prices please contact your nearest Infineon Technologies office (www.infineon.com).

WARNINGS

Due to technical requirements products may contain dangerous substances. For information on the types in question please contact your nearest Infineon Technologies office.

Except as otherwise explicitly approved by Infineon Technologies in a written document signed by authorized representatives of Infineon Technologies, Infineon Technologies' products may not be used in any applications where a failure of the product or any consequences of the use thereof can reasonably be expected to result in personal injury.